

SABARMATI RIVERFRONT DEVELOPMENT



**Sabarmati River Front Development
Corporation Limited**

**2nd Floor, Riverfront House,
B/h H.K Arts College,
Between Gandhi Bridge and Nehru Bridge,
Pujya Pramukh swami Marg
(River Front Road-West)
Ahmedabad-380009**

BID DOCUMENT

**CONSTRUCTION OF RIVERSIDE
SAVORIES I.E. BUILDING WITH
UNDERGROUND ROAD BETWEEN
NEHRU BRIDGE AND ELLISBRIDGE
AND CONSTRUCTION OF PUBLIC
PLAZA AND UNDERGROUND
PARKING FACILITY AT SANSKAR
KENDRA - TAGORE HALL CAMPUS
CONNECTING RIVERFRONT ON
WESTBANK FOR SRFDCL.**

Contract Package : SRFDCL

VOLUME-02

IV) Technical Specification-PHE



SECTION IV
TECHNICAL SPECIFICATIONS
Part A: - Riverside Savories



Contents

1.0	SANITARY FIXTURES & C.P. FITTINGS:	4
2.0	INTERNAL DRAINAGE (SOIL, WASTE, VENT AND RAINWATER PIPES)	7
3.0	TRAPS	10
4.0	TERRACE RAINWATER KHURRA, INLET MOUTH	11
5.0	DWC POLYETHYLENE PIPE	11
6.0	INTERCEPTING TRAP	15
7.0	PERCOLATION WELL & TUBEWELL:	15
8.0	CHLORINATED POLYVINYL CHLORIDE (CPVC) PIPES	25
9.0	PLUMBING INSULATION FOR HOT WATER SUPPLY	30
10.0	SWR - UPVC PIPES & FITTINGS	32
11.0	BALL VALVES (FLOAT VALVE):	33
12.0	BUTTERFLY VALVES	34
13.0	FLOT VALVE	39
14.0	REFLUX VALVE (NON-RETURN VALVE)	39
15.0	Y -STRAINER	42
16.0	GREASE TRAP	42
17.0	AIR RELEASE VALVE	43
18.0	BLANK FLANGE	43
19.0	GARDEN HYDRANT AND GARDEN HOSE PIPE	43
20.0	WOLTMAN TYPE BULK WATER METER- AMR BASED	43
21.0	MOSQUITO PROOF GRATING	44
22.0	R.C.C. PIPES	44
23.0	HYDROPNEUMATICS SYSTEM:	52
24.0	DRINKING WATER TREATMENT PLANTS	57
25.0	SS STORAGE TANK:	57
26.0	WATER COOLER WITH RO	58
27.0	BOREWELL DOMESTIC WATER TREATMENT PLANT	60
28.0	DEWATERING PUMP FOR SUMP DRAIN:	61
29.0	AIR TO WATER HEAT PUMP	63
30.0	HOT WATER RECIRCULATION PUMPS:	65
31.0	TUBE WELL WATER TREATMENT PLANT:	69
32.0	TUBE WELL SUBMERSIBLE PUMP:	73
33.0	INSTALLATION OF ENGINEERED SUPPORT SYSTEM	76
34.0	PLUMBING LIST OF APPROVED MAKES	82





DETAILED SPECIFICATIONS FOR PLUMBING WORK

1.0 SANITARY FIXTURES & C.P. FITTINGS:

Scope

Work under this section shall consist of transportation, furnishing, installation, testing and commissioning and all labor as necessary as required to completely install all sanitary fixtures, brass and chromium plated fittings and accessories as required by the drawings and specified hereinafter or given in the Bill of Quantities.

General Requirements

All fixtures and fittings shall be fixed with all such accessories as are required to complete the ITEM in working condition whether specifically mentioned or not in the Bill of Quantities, specifications, drawings or not.

All fixtures and accessories shall be fixed in accordance with a set pattern matching the tiles or interior finish as per architectural design requirements. Wherever necessary the fittings shall be centered to dimensions and pattern desired.

Fixing screws shall be half round head chromium plated brass with C.P. washers wherever required as per directions of Authority's Representative.

All fittings and fixtures shall be fixed in a neat workmanlike manner true to levels and heights shown on the drawings & in accordance with the manufacturer's recommendations. Care shall be taken to fix all inlet and outlet pipes at correct positions.

All fixtures of the similar materials shall be by the same manufacturers.

All fitting shall be of the chromium plated materials.

Without restricting to the generally of the foregoing the sanitary fixtures shall include all sanitary fixtures, C.P. fittings and accessories etc. necessary and required for the building.

Whether specifically mentioned or not all fixtures and appliances shall be provided with approved fixing devices, nuts, bolts, screws, and hangers as required. These supports shall have the necessary adjustment to allow for irregularities in the building area construction.

For the installation of the CP fittings, Teflon tape shall be used.

European W.C.

European W.C. of glazed vitreous china shall be wash down, single or double symphonic type, floor or wall mounted set, flushed by means of flush valve as specified in Bill of Quantities. Flush pipe / bend shall be connected to the W.C. by means of suitable rubber adopter. Wall hung W.C. shall be supported by C.I. floor mounted chair.

Each W.C. seat cover shall be so fixed that it remains absolutely stationary in vertical position without falling down on the W.C. Seat cover shall be of white solid plastic, elongated open front with heavy duty hinges. Exposed fixture trims shall be Chrome plated, and trims of similar function shall be by the same manufacturer.



Flushing cistern to be used shall conform to the requirements of IS: 774-2004. High level cisterns shall be of cast iron unless otherwise specified. Low level cistern shall be of the same material as the water closet or as instructed by the D.T.A./Authority. The cisterns shall be mosquito proof & shall fulfil the requirements of the local Authority.

If alternatively Flush valves to be used, then shall be of the best approved quality procurable with C.P. control valve and C.P. flush pipe.

The flush pipe/bend shall be connected to the WC by means of a suitable rubber adopter.

Flushing cistern to be used shall conform to the requirements of IS: 774-2004. High level cisterns shall be of cast iron unless otherwise specified. Low level cistern shall be of the same material as the water closet or as instructed by the D.T.A./Authority. The cisterns shall be mosquito proof & shall fulfil the requirements of the local Authority.

The levels of the WC should be checked by placing spirit level on the W.C. W.C. should be tested on completion of fixing by putting small paper balls and flushing out. If all the paper balls are not flushed out. The fixing will have to be rectified / re-aligned.

Wash Basins

Wash basin shall be of white vitreous china of best quality manufactured by an approved firm and sizes as specified in the Bill of Quantities.

Wash basin shall be of under counter drop in type shall be supported on a pair of rolled steel brackets of approved design and shall be mounted on a countertop. So that rim and basin bowl is exposed from top.

Wash basin shall be provided with single lever mixer with chain and rubber plug, chromium plated brass bottle trap of approved quality, design and make where hot water required. Single tap where hot water is not required.

Wash basin shall be fixed at proper location and height and truly horizontal as shown on drawing or as directed by Authority's Representative.

Urinals

Half stall wall hung urinals of glazed vitreous china shall be provided with 15mm dia, C.P. brass spreader, 32/40/50mm dia C.P. domical waste and C.P. cast brass bottle trap with pipe and wall flange and shall fixed to wall by one C.I. bracket and two C.I. clips as recommended by manufacturers complete as directed by the Authority's Representative.

Urinals shall be flushed by means of "NO-TOUCH" infrared operated flush valves.

Urinal Sensor have Sensotronic Concealed Type Flushing Valve for Urinal Complete Set with Installation Box with Control Cock.

Waste pipes for urinals shall be any one of the given materials as directed by the Authority's Representative:

- A. G.I Pipes
- B. Rigid PVC/High density polyethylene.



- C. Waste pipes may be exposed on wall or concealed in chase as directed by the Authority's Representative.

Paper Holder

Toilet recessed type paper holder complete in all respects including cutting and making good the walls etc.

BIB Cock

These shall be of C.P. brass bib cocks of best quality necessary fittings with wall Flange etc. complete in all respects including cutting and making good the walls etc.

Angle Valve

These shall be of C.P. brass angle valve with C.P. copper connecting pipe 450 mm long and nuts, washer and brass flange complete, including cutting and making good the wall where required.

Liquid Soap Container

These shall be of C.P. brass liquid soap container of best quality etc. complete in all respects including cutting and making good the walls etc. These shall be fixed by means of stainless-steel screws to wooden / plastic cleats firmly embedded in the wall.

Kitchen / Pantry Sinks

Sinks shall be of stainless-steel material as specified in the Bill of Quantities/Drawings. Each sink shall be provided with R. S. brackets and clips and securely fixed. Countertop sinks shall be fixed with suitable angle iron clips or brackets as recommended by the manufacturer. Each sink shall be provided with 40 mm dia Chromium Plated waste with chain and plug or P.V.C. waste with Escutcheon plates. Fixing shall be done as directed by Authority's Representative. Supply fittings for sinks shall be mixing fittings or C.P. taps, angle cocks etc. all as specified in the Bill of Quantities/Drawings.

Braided Hose Copper Pipe

Providing and fixing of C.P. copper connecting pipe 450 mm long and nuts, washer and brass flange complete, including cutting and making good the wall where required etc. complete as per directed by the Engineer's Representative.

Pressmatic Pillar Cock

Providing and fixing Pressmatic Pillar Cock of best quality necessary fittings with wall Flange etc. complete in all respects including cutting and making good the walls etc. complete as per directed by the Engineer's Representative.

Sink Cock

Sink cock of best quality necessary fittings with wall Flange etc. complete in all respects including cutting and making good the walls etc.

Health Faucet



Hand Shower (Health Faucet), with 8mm Dia. 1 -1.2 mtr Long flexible Tube and Wall Hook with accessories of best quality necessary fittings with wall Flange etc. complete in all respects including cutting and making good the walls etc.

Hand Dryer

Hand dryer, fully automatic type, cover shall be fabricated in extra heavy duty 18 gauge type 304 SS/ ABS with exposed surfaces satin finished, the unit shall deliver not less than 71 l/sec of hot air and electrical rating shall be 240 V / 1 phase / 50 cycles.

Urinal Partition

Providing and fixing Urinal partition with frosted glass approx. size 900 MM (H) X 450 MM (W) having 10 MM of glass thickness, including fixing to wall with suitable brackets all as per manufacturers specification etc

Automatic Fragrance Dispense

These shall be of C.P. brass Automatic Fragrance Dispense fixed to wooden cleats with C.P. brass screws complete the item.

Quote & Hat Hook

These shall be of C.P. brass twin way QUOTE and hat hooks fixed into wall with C.P. Brass screws and wall plugs etc. complete including cutting and making good the walls etc.

Grab Bar

grab bar fabricated seamless stainless steel tube in bath room with non-slip gripping surface, polished wall flange at end of bars with heavy duty anchor fasteners and accessories etc complete the job.

Recessed convertible paper towel dispenser and waste receptacle

Item shall be Type-304 stainless steel with welded construction; exposed surfaces shall have satin finish. Flange shall be drawn and beveled, one-piece, seamless construction. Door shall be secured to cabinet with a full-length stainless steel piano-hinge and equipped with a semi-concealed tumbler lock keyed like other Bobrick washroom accessories. Paper towel dispenser shall dispense 600 C-fold or 800 multifold paper towels. Removable waste receptacle shall be secured to cabinet with a tumbler lock, have front and side edges of bottom and all top edges hemmed for safe handling, and shall have a minimum capacity of 12-gal. (45.5-L).

2.0 INTERNAL DRAINAGE (SOIL, WASTE, VENT AND RAINWATER PIPES)

Scope

- A. Work under this section shall consist of furnishing all labor, materials, equipment and appliances necessary and required to completely install all soil, waste, vent and rainwater pipes as required by the drawings, specified here in after and given in the Bill of Quantities.
 - a. Without restricting to the generality of the foregoing, the soil, waste, vent and rainwater pipes system shall include the followings: -
 - i. UPVC vertical and horizontal soil waste and vent pipes, rainwater pipes and fittings, joints clamps and connections to fixtures.

Signature of Bidder



- ii. Floor traps, floor drain clean out plugs, inlet fittings and rainwater roof drain, area/local drains, trench drain.
- iii. Waste pipes connections from all fixtures e.g., wash basins, sinks, kitchen equipment.
- iv. Testing of all pipes.
- v. Connection of main.

General Requirements

- A. All materials shall be new of the best quality conforming to specifications and subject to the approval of Authority's Representative.
- B. Pipes and fittings shall be fixed truly vertical, horizontal or in slopes as required in a neat workmanlike manner.
- C. Pipes shall be fixed in a manner as to provide easy accessibility for repair and maintenance and shall not cause obstruction in shafts, passages etc.
- D. Pipes shall be securely fixed to walls by suitable clamps at intervals specified.
- E. Access doors for fittings and cleanouts shall be so located that they are easily accessible for repair and maintenance.
- F. All works shall be executed as directed by Authority's Representative.

A. UPVC pipes and fittings

The pipes shall be round and shall be supplied in straight lengths with socketed ends. The internal and external surfaces of pipes shall be smooth, clean, and free from grooving and other defects. The ends shall be cleanly cut and square with the axis of the pipe. The pipes shall be designated by external diameter and shall conform to IS: 4985 – 2000.

Fittings

Fittings shall be of the same make as that of pipes, injection moulded and shall conform to Indian Standard.

Laying and Jointing

The pipes shall be laid and clamped to wooden plugs fixed above the surface of the wall. Alternatively plastic clamps of suitable designs shall be preferred. Provision shall be made for the effect of thermal movement by not gripping or disturbing the pipe at supports between the anchors for suspended pipes. The supports shall allow the repeated movements to take place without abrasion.

Jointing for UPVC pipes shall be made by means of solvent cement for horizontal lines and 'O' rubber ring for vertical line. The type of joint shall be used as per site conditions/direction of the Authority's Representative. Where UPVC pipes are to be used for rainwater pipes, the pipe shall be finished with G.I. adopter for insertion in the R.C.C. slab for a waterproof joint complete as directed by Authority's Representative.

Supports

UPVC pipes require supports at close intervals. Recommended support spacing for unplasticised PVC pipes is 1400 mm for pipes 50 mm dia. and above. Pipes shall be aligned properly before fixing them



on the wooden plugs with clamps. Even if the wooden plugs are fixed using a plumb line, pipe shall also be checked for its alignment before clamping, piping shall be properly supported on, or suspended from clamps, hangers as specified and as required. The Contractor shall adequately design all the brackets, saddles, anchors, clamps and hangers and be responsible for their structural sufficiency. Pipe supports shall be primer coated with rust preventive paint.

Repairs

While temporary or emergency repairs may be made to the damaged pipes, permanent repairs should be made by replacement of the damaged section. If any split or chip out occurs in the wall of the pipe, a short piece of pipe of sufficient length to cover the damaged portion of the pipe is cut. The sleeve is cut longitudinally and heated sufficiently to soften it so that it may be slipped over the damaged hard pipe.

Testing

All lengths of PVC rainwater pipes shall be fully tested for water tightness by means of water test maintained for not less than 30 minutes. All pipes shall be subjected to a test pressure of at least 1.5 meter head of water head. The test pressure shall, however, not exceed 6 meter head at any point. The pipes shall be plugged preferably with standard design plugs with rubber plugs on both ends. The upper end shall, however, be connected to a pipe for filling with water and getting the required head.

B. Waste pipe from Appliance

- a. Waste pipe from appliances e.g., wash basins, sinks, urinals, chrome plate where seen water coolers shall be of uPVC rigid pvc pipe.
- b. All pipes shall be fixed in gradient towards the outfalls of drains. Pipes inside a toilet room shall be in chase unless otherwise shown on drawings. Where required pipes may be run at ceiling level in suitable gradient and supported on structural clamps. Spacing for clamps for such pipes shall be as follows:

	Vertical	
Horizontal		
P.V.C. Pipes	180 cms	120 cms

C. Measurements

Waste/soil, waste, vent and rainwater pipes shall be measured over all along the centre line correct to a centimeter including all fittings along its length. The rate for these pipes shall be inclusive of all fittings, holder bat clamps, lead caulked joint for C.I. and cement joints for UPVC and all other items described in the Bill of Quantities. The portion of the pipe within the collar for C.I./UPVC pipe at the joint shall not be included in the length of the pipe work.

D. SWR uPVC Pipes and fittings

Soil, waste, vent SWR Ring Fit/Solvent pipes with socket and spigot. All pipes shall be straight and smooth and inside free from irregular bore, blow holes, cracks and other manufacturing defects. These pipes conform to EN 1329 / IS 13592 (SWR type B) and are designed to withstand continuous internal hydraulic pressure of 6 Kg/cm to ensure life-long trouble-free working. The pipes are provided with an integral rubber ring type socket at one end while the other end is kept plain, smooth and free from burrs. Rubber ring type socket ends provide easy push – fit type jointing. Simultaneously, allowance for thermal expansion can also be provided during installation.



Fittings

Fittings shall conform to the corresponding Indian Standard as for pipes. Contractor shall use pipes and fittings of matching specification.

Access door shall be secured air and watertight with 3mm thick insertion rubber washer and white lead. The bolts shall be lubricated with grease or white lead for easy removal.

Jointing

1) Rubber Seal Rings for Joints & Access Doors

Manufactured in accordance with IS: 5382 for 75 mm / 90 mm / 110 mm sizes. These are made out of natural rubber with a shore 'A' hardness of 40 × 5. Provide superior resistance to biological attack. Special design of cross section ensures perfect sealing.

2) Lubricant

Available in 100 gms, 250 gms & 500 gms packing. Specially formulated for compatibility with rubber seal as well as PVC. Does not support the growth of bacteria or fungi.

E. Pipe, Hangers, Support, Clamp, Bracket etc.

Supports

UPVC pipes require supports at close intervals. Recommended support spacing for unplasticized PVC pipes is 1400 mm for pipes 50 mm dia. and above. Pipes shall be aligned properly before fixing them on the wooden plugs with clamps. Even if the wooden plugs are fixed using a plumb line, pipe shall also be checked for its alignment before clamping, piping shall be properly supported on, or suspended from clamps, hangers as specified and as required. The Contractor shall adequately design all the brackets, saddles, anchors, clamps and hangers and be responsible for their structural sufficiency. Pipe supports shall be primer coated with rust preventive paint.

Testing

Before the system is put into use, it should be tested for leakages by air test, hydraulic test or smoke test.

3.0 TRAPS

1) FLOOR TRAPS/P-TRAP

Floor traps/P-TRAP shall be PVC deep seal with an effective seal of 50 mm. The trap and waste pipes shall be set in cement concrete blocks firmly supported on the structural floor. The blocks shall be in 1:2:3 mix (1 cement: 2 coarse sand: 4 stone aggregate 20 mm nominal size) mixed with water proof compound and extended to 40 mm below finished floor level. Contractor shall provide all necessary shuttering and centering for the blocks. Size of the block shall be 30 x 30 cms of the required depth. The trap shall be installed at lowest point ensure no pending occurs at perimeters of the drain.

2) MULTI FLOOR TRAPS/P-TRAP

Floor traps/P-TRAP shall be Low noise (PP), deep seal with an effective seal of 50 mm. The trap and waste pipes shall be set in cement concrete blocks firmly supported on the structural floor. The blocks shall be in 1:2:3 mix (1 cement: 2 coarse sand: 4 stone aggregate 20 mm nominal size) mixed with water



proof compound and extended to 40 mm below finished floor level. Contractor shall provide all necessary shuttering and centering for the blocks. Size of the block shall be 30 x 30 cm of the required depth. The trap shall be installed at lowest point ensure no pending occurs at perimeters of the drain.

Floor Trap Inlet

Bathroom traps and connections shall ensure free and silent flow of discharging water. Where specified, the Contractor shall provide a special type of galvanised iron inlet fitting without or with one, two or three inlet sockets to receive the waste pipe. Joint between waste and fitting shall be connected to a C.I. 'P' or 'S' trap with at least 50mm seal (Hopper and traps shall be paid for separately). Floor trap inlet fittings and the trap shall be set in cement concrete blocks.

C.P./Stainless Steel Gratings

Providing & fixing PVC SWR TYPE B P Trap of 110 X 110 mm diameter with Height riser/ necessary 110MM Diameter of distance piece for wash basin/ sink drain connection with cockroach trap - square flat cut, Satin-matt finish - 150mm x 150mm of approved Make, making necessary slab/ wall/ beam holes and cutting walls, etc. complete.

Providing & fixing PVC SWR TYPE B of 110 X 110 mm diameter with Height riser/ necessary 110MM Diameter of distance piece for urinal drain connection with floor clean out square cut 150mm- Satin of approved Make, making necessary slab/ wall/ beam holes and cutting walls, etc. complete.

Cleanout Plugs

Providing & fixing floor clean out square cut 150mm- Satin of approved Make with making necessary slab/ wall/ beam holes and cutting walls, etc. complete.

Pipe Sleeves

Pipe sleeves 50mm larger diameter than pipes shall be provided wherever pipes pass through walls and slabs and annular space filled with fireproof materials like putty, fire seal etc. All pipes shall be accurately cut to the required sizes in accordance with relevant BIS codes and burrs removed before laying. Open ends of the pipe shall be closed as the pipe is installed to avoid entrance of foreign matters. Vertical sleeve shall finish 50mm above finish floor level.

4.0 TERRACE RAINWATER KHURRA, INLET MOUTH

Khurra

Khurras 45x45cm with average minimum thickness of 5 cm. cement concrete 1:2:4(1 cement:2 coarse sand :4 graded stone aggregate of 20mm nominal size) over P.V.C. sheet 1mx1mx400micron, finished with 12mm cement plaster 1:3 (1 cement: 3 coarse sand) and a QUOTE of neat cement rounding the edge sand making and finishing the outlet complete.

Inlet Mouth

Inlet mouth of rainwater pipe with cast iron grating 15cm diameter not less than 440gram.

5.0 DWC POLYETHYLENE PIPE

(Class SN 8 Structured Double Wall (Non-Smooth External Annular Corrugated wall & Smooth Internal wall) Polyethylene Piping System for non-pressure underground Sewerage & Drainage Applications)



Scope

This specification covers the requirements for manufacturing, supplying, transportation, handling, stacking of Class SN 8 Structured Double Wall (Non-Smooth External Annular Corrugated wall & Smooth Internal wall) Polyethylene Piping System for non-pressure underground Sewerage & Drainage Applications herein after called the DWC PE Piping System.

Applicable Codes

The manufacturing, testing at factory, supplying, transportation, handling, stacking, installation, jointing, and testing at sites shall comply with all currently applicable statutes, manuals, regulation, standards & codes. In particular, in addition to all relevant National Standards, following international standards with latest revisions shall be referred. If requirements of these specifications are at variance with any other standards, this particular document shall govern the proceedings.

EN 13476-1	Plastics piping Systems for non-pressure underground drainage and sewerage-Structured-wall piping systems of Polyethylene (PE) Part 1: General requirements and performance characteristics
EN 13476-3	Plastics piping Systems for non-pressure underground drainage and sewerage-Structured-wall piping systems of Polyethylene (PE) Part 3: Specifications for pipes and fittings with smooth internal and profiled external surface and the system, Type B

Other International Codes / Standards (EN/ ISO) which are integral part of above two standards as normative references form a significant portion of this specification document.

Manufacturing

The DWC PE Piping System of stiffness class designation SN 8 shall conform to the European Union standards as mentioned above and shall be configured as per the indicative Cross-sectional & Profile Drawings (Annexure A &B) annexed herewith. Each pipe shall be coupler (on-line or off-line) and spigot type along with rubber sealing ring (as designated under above international specifications).

Transportation

The arrangement of loading the pipes in a telescopic manner is advised, i.e. smaller diameters inserted into the next higher sizes of pipes. While loading the pipes onto the truck, care should be taken that the coupler- end should be arranged alternatively in the corresponding layers so as to avoid the damage to the coupling/ socket ends.

Handling

Following Recommendations shall be followed while handling the pipes:

- Adherence to National Safety requirements
- Pipes to be smoothly lowered to the ground
- Pipes should not be dragged against the ground to avoid the damages to the Coupler/pipes.
- 800mm and larger diameter pipes are carried with Slings at two points spaced approximately at 3 Meters apart
- For smaller diameters (400mm – 800mm) one lift point shall be sufficient & can be handled either manually or mechanically
- Do not use a loading Boom or Forklift directly on or inside pipe.

Pipe Storage at Site



- Stockpiling shall be done temporarily on a Flat Clear Area as per Fig. 1 & 2.
- For avoiding collapse of Stacks, use Wooden Posts or Blocks
- Stacking shall not be higher than 2.5 Meters
- While stacking, alternate the socket/coupler ends at each row of stacked pipes as per Fig. 2.



(Fig 1)

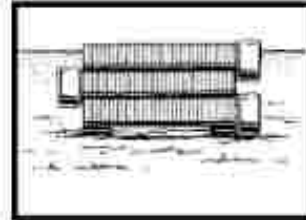

(Fig 2)

Lowering, Laying & jointing of Pipes

The width of a Sewer Trench depends on the soil condition, type of side protection needed, and the working space required at the bottom of Trench for smooth installations. Increase in width over required minimum would unduly increase the load on pipe and cost of road restoration. Considering all above factors, the Minimum Trench Width is specified as per Table below: -

Indicative Trench Widths**	
Pipe Diameter (mm)	Trench Width (M)
75-170	0.6
250	0.7
400	0.9
600	1.2
800	1.3
1000	1.8

**In actual practice the trench width can be as narrow as possible but adequate to allow the workmen to execute the job satisfactorily.

The pipe segment between two manholes shall be laid approximately in straight line without any vertical undulations. However, on the strength of its flexibility, the DWC PE Piping system can be laid in very smooth curve if found necessary. The piping system shall rest on the carefully prepared bedding portion of the Backfill Envelope and at appropriate jointing locations the trenches shall be excavated deeper to accommodate the bulges of coupler-spigot joints. However, special care shall be ensured as mentioned below:

- Excavation of trenches shall be carried out in accordance with the drawing & specifications and as directed by the field engineer as well.
- The piping system shall be laid and jointed in true to gradient with the help of sight rails and boning rods as detailed in CPHEEO Manual on Sewerage and sewerage treatment. The levels need be checked with calibrated modern Levelling Instrument. Specific care shall be taken to prevent entry of sand / mud / slush / any other foreign material etc into the system during the installation operation.

The structural property of the system suggests that a minimum cover of 300 mm adequate even for maximum quantum of superimposed (live) load.

In case of wider trenches than required (above table), the permission of the competent authority shall be necessary.



The bedding area is an essential portion of Back fill Envelope and shall be constructed with proper bedding material as computed in accordance with appropriate international code of practice for structural bedding design mentioned in the list of normative references under EN 13476. The bedding shall be laid to specified thickness and gradient with proper manual compaction of the aggregate.

The moulded on-line coupler (or separate coupler integrated to the pipe in case of lower sizes) will have a suitable internal surface for push-fitting the said end over the spigot end of the next pipe. On first valley of the corrugation of said spigot end (destined to receive the pushed coupler) the sealing rubber ring of standard (EN 13476) quality shall be placed so that the coupler end of the pipe smoothly but tightly slides over the sealing ring for making an absolute watertight joint. Similar system is also used for fabricated accessories or moulded fittings required such as Tee, Bends, Elbows, Reducer end caps for the purpose of installation of the system related to drainage/sewerage.

For quality connections following steps are to be ensured, failing which the performance aspects are to be severely compromised.

The non-coupler (socket) end needs to be thoroughly cleared and shall be free from any foreign material

- Clean and lubricate the coupler end of the pipe, if required.
- Lubricate the exposed Gasket in the same manner, if required.
- Keep the non-coupler end free from dirt, backfill material, and foreign matter so that the joint integrity is not compromised.
- Push the coupler into non-coupler and align properly. Always push coupler end into non-coupler end.

For smaller diameter pipes simple manual insertion shall be sufficient. It should be ensured that the coupler end is adequately 'homed' within non-coupler end to ensure installation and tight joining seal. Therefore prior to insertion always place a 'Homing Mark' on appropriate corrugation of the 'Non-Coupler End'.

Construction of backfill envelope and final backfilling of the trenches

DWC PE Piping System with well compacted Backfill Envelope along with the bottom and sides of trench (native soil) work together to support soil overburden and superimposed (traffic) loads. The carefully constructed Backfill Envelope has three distinct but non-isolated stages. The construction needs to be done stage by stage as per the sequence stated below:

- Bedding portion
- Up to Haunch level
- Remaining portion

The material for backfill envelop shall be in accordance with the structural design of flexible buried conduit as per relevant international codes. It can be the same material that were removed in the course of excavation, or it can be fine sand/course sand/gravel / moorum /other form of course / fine aggregates depending on the effected Design Load [Overburden + Superimposed (Live) load]. However, in no circumstances, the flexible pipe should not be embedded in cement concrete (un- reinforced or reinforced) which invariably induces undesired rigidity in the system.

- The remaining portion of backfilling which do not contribute to the structural integrity of the system may be the materials that were removed in the course of excavation, or any other foreign material as may be required to suit the particular site condition. These materials shall consist of at least clean earth and shall be free from large clod or stone above 75 mm, ashes, refuse and other injurious materials.
- After completion of bedding portion of the Backfill envelop and subsequent lying of pipes, etc, first the haunch portion & then upper portion of Backfill Envelope shall be constructed as per design



around the pipe. Voids must be eliminated by knifing under and around pipe or by some other indigenous tools.

- The compaction, by hand rammers or compactors with necessary watering to a possible maximum level of proctor density shall be ensured.
- Backfilling shall start only after ensuring the water tightness test of joints for the concerned sewer segments. However, partial filling may be done keeping the joints open.
- Precautions shall be taken against floatation (if at all necessary) as per the specified methodology and the minimum required cover.
- Continuity of the pipe segments in between two manholes is required to be ensured in the same modality as practiced for pipeline. Hydraulic testing of pipes shall be done, if specifically asked for by the client for any specific stretch.

Jointing

- Elastomeric sealing ring joints/Solvent cement joint
- These pipes shall be socketed on automatic socketing machine with self-socket length. Such pipes shall be either joined with solvent cement or groove inside with rubber ring.

Continuity Test /Hydraulic Testing

- All lengths of the sewer and drain shall be fully tested for water tightness by means of water pressure maintained for not less than 30 minutes. Testing shall be carried out from manhole to manhole. All pipes shall be subjected to a test pressure of at least 1.5 mtrs. head of water. The test pressure shall, however, not exceed 6 metres head at any point. The pipes shall be plugged preferably with standard design plugs with rubber plugs on both sides. The upper end shall, however, be connected to a pipe for filling with water and getting the required head poured at one time permit.
- Sewer lines shall be tested for a straightness by:
 - Inserting a smooth ball 12 mm less than the internal diameter of the pipe. In the absence of obstruction such as yarn or mortar projecting at the joints the ball should roll down the invert of the pipe and emerge at the lower end.
 - Means of a mirror at one end and a lamp at the other end. If the pipeline is straight the full circle of light will be seen otherwise obstructions or deviations will be apparent.
- The contractor shall give a smoke test to the drain and sewer at his own expense and charges, if directed by the Engineer in charge.
- A test register shall be maintained which shall be signed and dated by Engineer in charge.

Measurements

The mode of measurement shall be as per Schedule B.

6.0 INTERCEPTING TRAP

Providing and fixing intercepting trap of 150mm diameter in manholes with stiff mixture of cement mortar 1:1 (1 cement : 1 fine sand) including testing of joints etc

7.0 PERCOLATION WELL & TUBEWELL:



PURPOSE: to recharge by the way of drilling tube wells using storm water received through external surface.

REQUIREMENT:

- Geophysical (electrical resistivity) & hydrogeological, geology, hydrology survey and submit the report along with bore logging & electrical resistivity test.
- finding stratification of aquifer system and spatial variability of hydraulic conductivity of different zones.
- negative and nonproductive zones of low hydraulic conductivity.
- vertical hydraulic conductivity.
- moisture content and infiltration.
- direction of ground water flow.
- salinity changes
- finalization of physical data
 - location of proposed structure
 - determination of number of structures
 - identification of tentative location.
- location identification- assessment of existing studies & recommendation
- geo tagging/google map -ne co-ordinates
- drilling pilot tube well to assess potentiality.

DESIGN REQUIREMENT:

- Otestis prior to commencement
- Oflow requirements/ rate of discharge/percolation
- Owater report- samples of water for analysis:
- Oinfiltration rates
- Overticality of tube wells
- Ofilter pack
- Ocasing pipe.

INCLUSION:

- drilling report
- infiltration record
- preliminary works for drilling, boring, access to specific areas
- water for all purposes
- power-dg or chargeable
- storage godown
- manpower colony arrangements outside site premises
- standard statutory obligation & responsibilities
- authority & departmental co-ordination
- post completion approval from cgwa
- amc-yearly & activities & schedule
- all rates are for site
- housekeeping & sealing & making good the area post completion of the works-handing over to client
- identification boards for each percolation wells



- as built drawings
- drilling & boring in all soil/rock as applicable using appropriate type of rig such as rotary, semi rotary and dth.
- safety & security during construction
- standard ohs & ehs requirements
- third part quality report/mtr
- all insurances other than car policy
- inclusion & exclusion list
- local issues if any

SPECIFICATION OF RECHARGE WELL

Construction of Percolation Well with all required connections as per detailed design and drawing with all required accessories. Scope shall include for Borewell depth up to 200m. with 3 m dia with 4m liquid depth+ invert Level with silting chamber(1.5mx0.75mx1.2m +IL) and overflow connection to the nearest drain. ITEM shall also including of precast/ RCC filtration module including of necessary filtration media for silt chamber and recharging pit.

DEVELOPMENT OF TUBE WELLS

SCOPE :

The scope includes construction of tube well to get required quantity of potable water with all material, testing, etc.

It is proposed to drill the tube well at the proposed in attached site plan or as per vendor based on resistivity survey or as per res in accordance with ISSR NO. 2800 - 1964 or latest.

The process to be adopted with direct rotary circulation method and tube well is to be installed as per the schedule where the actual length of housing pipe screen and blind pipe is to be worked out in accordance with the availability of strata. The annular space between the wall of hole and stainless-steel screen is to be packed with the suitable size of graded gravel to make the area immediately around the well bore for the flow of water to prevent sand from entering the well during pumping.

GENERAL :-

A. The purpose of constructing the tube well is to percolate ground water. The depth shall be according to the strata available as per site condition. It will have M. S. ERW housing pipes.

B. Below housing pipe, there shall be casing pipe having minimum thickness of 8 mm. Pipes shall be as per IS 1239 or 3589 /1991 and MS heavy duty strainer pipes for deep tube well shall be used.

METHODOLOGY / APPROACH

Process /methodology involved in construction of wells up to 200m depth (or up to hard rock)

- A)site selection and pinpointing of site
- B)shifting of rig
- C)site preparation
- D)pilot hole drilling

Signature of Bidder



- E)sample collection & preparation of lithology
- F)bore hole logging (resistivity/natural gamma)
- G)determining size of gravel packing
- H)preparation of composite log using data of (e) & (f) above
- I)designing of well assembly
- J)reaming of bore hole
- K)lowering of well assembly
- L)back washing, shrouding of gravel and clay packing (cement sealing, if required)
- M)measurement of yield using v notch/ volumetric method after encountering each fracture zone and simultaneous water sample collection and quality analysis for individual fracture zone
- N)verticality test of well
- O)development of well by air compressor/ pumping
- P)electrical logging/ caliper logging (need based)
- Q)percolation test
- R)water sample collection for analysis of basic & heavy metals under guidance of site hydrogeologist/ chemist.
- S)construction of platform, well capping and installation of protection box
- T)preparation of basic data report & submission
- U)handing over of well

DEFINITION:

In this contract a tube well will mean :-

A.satisfactory completion of bore hole drilling to the maximum prescribed depth in all type of strata, which shall include various kinds of water bearing strata including small boulder. The stated depths are approximate, and the contractor may have to go higher, or lower depth as decided by client as per condition of strata generally available in the site locality

The contractor shall have to arrange for electro logging and cost shall include the same .

B.the work includes installation of casing and housing pipes complete with strainer or slotted pipes including bail plug, reducer, clamp, top half coupling and well cap. The housing pipes, casing pipes, johnson strainer pipes, reducer, clamp wooden slippers well cap, half coupling and cone of bail plug shall have to be supplied by the contractor.

C.work includes placing of a gravel packing around casing housing and strainer pipes as per design. All gravel as per specification of required quality of (and) quantity will be supplied by contractor.

D.work includes strata wise development of gravel packed tube well with adequate capacity air compressor.

E.the work includes development of gravel packed tube well with submersible pump with the object of obtaining a suitable quantity yield & shall nearly become sand free after 5 minutes of starting.

F.the scope also includes measuring of eccentricity and sound.



G.the scope shall also include well cap, bail plug, etc. Complete.

DRILLING PROCEDURE:

A.the contractor will employ direct rotary circulation method rig for the drilling of well. The design of the wall for the discharge anticipated through will be of the firm. Yet the contractor is to continue drilling up to any depth when ordered by the engineer in charge (e.i.c.) in writing. The strata chart prepared on the basis of observation has to get approved from e.i.c. before arranging and installing the columns assembly through the responsibility for the design of the well will be that of the firm. If the e.i.c. feels that the sufficient water bearing strata has not been obtained drilling will be stopped when directed by the e.i.c. in writing.

B.all water bearing strata decided by the e.i.c shall be tapped.

C.the contractor shall have to drill first a pilot bore and after completion of which the contractor shall have to inform e.i.c. for electro logging. Contractor shall have to arrange for electro logging of each bore. Without electro logging of bore, rimming work should not be started in any case.

D.after pipe and strainer lowering in the bore hole and before gravel packing. minimum hours back washing is required to keep proper mud density.

E.after gravel packing work, minimum hours back washing is required with clean water, putting washing line at the bottom.

F.the contractor shall have to use fresh quality of bentonite so that the mud salinity should be less than 230 ppm.

G.bore hole shall be drilled freely in plumb and vertical.

CONSTRUCTION OF TUBE WELL

A.DRILLING :

(A)after satisfactory drilling and bore hole rimming the contractor shall have to arrange lowering, installing and welding of housing pipes, casing pipes and strainer pipes including reducer, bail plug, joint covering strip, coupling, well cap etc. The contractor shall have to bring all the materials like bore pipes, reducers, strainer pipes, well cap, cone etc. Two days prior to lowering with necessary test certificates for approval of engineer in charge. The contractor shall have to obtain written permission from the engineer in charge only after these he can start lowering of the pipes in presence of client's engineer. The clamp shall applied to the housing pipes supporting to the pipe 0.5 mt below the ground level and supported with wooden slippers. Before lowering housing and casing pipes it should be painted with black anticorrosive bituminous paint.

B.GRAVEL PACKING AS PER IS 4097-1967 OR LATEST :

(A)after the pipe assembly is lowered into position it is to be packed with suitable size of gravel to be designed on the basis of the analysis of character of water bearing formations in the first instance of gravel packing is to be done up to the bottoms of housing pipe. The verticality of the housing pipe is to be tested and defects if any to be rectified to assure that it is not out of vertical. Thereafter the position



of housing the pipe is to be secured and the gravel packing up to the top to be completed. Feeding of the gravel is to be done in such a manner that there is no bridging in annular space. To avoid the bridging it would be helpful if the circulated fluid is pumped to agitate the gravel as it is being fed.

C. CASING

(i)ms casing pipes/ slotted pipe as specified in above should confirm to the specification given below.

(ii)bis marked steel tubes plain ended for water wells of type erw conforming to table no 3 of is: 4270/2001 (third revision).

(iii)a length of 0.50 m of casing pipe should be left above the ground level.

(iv)ms casing pipe should be installed perfectly vertical on the consolidated rock basement in such a manner that there should not be leakage of air during drilling. The annular space between the casing and the borehole wall should be grouted with cement slurry to avoid entry of local foreign material in the borehole in consolidated formations. The annular space above gravel pack may be filled with local clay in case of soft rock formation.

(v)well cap should be securely sealed to the pipe after bore hole is checked by the engineer-in charge. The well cap should be fabricated as per the provided specifications by client.

D.CONSTRUCTION OF PLATFORM, WELL CAP, PROTECTION BOX AND DISPLAY BOARD

After the completion of well in all respects described above, the contractor shall fabricate and install well cap using MS plate of minimum thickness 6mm, make platform around well, and install Display Board and Protection Box.

FOLLOWING TO BE IN BIDDER SCOPE-

- cement sealing by means of mud pump with cost of cement etc.
- mud pit
- mud lifting tanker

Note: bidder must follow latest cgwa notification for construction of tube well.

DEVELOPMENT OF TUBE WELL :

(A)the well shall be developed with the help of air compressor in first instance to assure proper slotting of the gravel and after each a strainer it properly dealt. The development is to continue with the help of reverse pumping set at a depression of 30ft. Or at a distance of 50% higher than the design discharge of the tube well which so ever is more including cost of water. The tube well is to be completely made sand free with no turbidity or at a most turbidity as defined in the ministry of health standards for drinking of water. After a contractor has reported that the development of tube well is completed. The tube well to be offered for testing observations are to be recorded in the shape of chart enclosed in the annexure in the manner prescribed in 155 – 2800 – 1964 or as per latest cgwa guideline.



(b) the water tanker for work of drilling and developing for the tube well will not be provided by client in any circumstances. The contractor has to arrange for water tanker at its own.

VERTICALITY TEST :

The tube well when out of alignment containing kinkers bend or core – screw is to be rejected straight way. The housing should be true to the line and the deviation from its top to the reducing socket in no case is more than 50 mm in the case when the housing pipe is 25 mtrs. Long and 75 mm when it is 30 mtrs. The deviation shall be in one direction and in one plan only. The deviation of the tube well is to be determined according to the method specified in ISS 2800 – 1964.

DATA COLLECTION

DRILLING CONTRACTOR WILL.

(i) maintain a drill time log for every 3 m for wells drilled.

(ii) measure discharge over 90° v notch plate during drilling on every increase/ decrease of yield at various depths for wells drilled in hard rock formations.

(iii) collect formation samples of minimum 500 g mass at an interval of 3m or change of formation during drilling and properly pack in polythene bags and label with date/ depth/ location.

(iv) collect 1 liter water sample during the following stages:

A. For every water-bearing zone encountered for wells drilled.

B. After development is complete and during test for wells drilled.

Necessary arrangements are to be made for verification by engineer-in-charge for checking of depth of borehole, length of casing, static water level, discharge and any other requirement as shall be felt necessary from time to time. A guest tent should be pitched at the site during drilling/ testing and provided with table and chairs for the engineer-in-charge.

SUCCESSFUL AND UNSUCCESSFUL WELL.

Success of well will be decided by the Engineer-In-Charge. In case of non-availability of minimum thickness of aquifer capable of yielding expected discharge, the bore hole may be abandoned and payment based on actual work carried out will be made at quoted rates. The tube well abandonment committee will be constituted by concerned personnel from Client.

AQUIFER PERCOLATION TEST (APT)

The contractor has to carry out the apt in order to determine transmissivity, specific yield/ stativity in wells through reverse pumping/ tanker test method.

THE CONTRACT REPORT:

The contractor is required to furnish the following information:



A.he should recommend the suitability of site proposed by the client and in case of difference in opinion: he should suggest other site nearby for the required design of the tube well.

B.whether the test bore is proposed, and if yes its diameter and depth.

C.depth of tube well for shallow & deep well for availability of potable water respectively

D.method of drilling

E.size and types of different strainer or slotted pipe etc.

F.probably yields of the water.

G.he should guarantee with regard to the verticality of the tube well and sand contents in the discharge at the time handling over the well.

FINAL TEST

The contractor shall give following certificates.

A.material test certificate and routine test certificate for m. S. Erw pipes as per is 1239 or 3589/1981.

B.material test certificate and routine test certificate for johnson filtration make continuous slotted strainer pipes.

C.strata chart showing all the technical detail in triplicate as per the attached annexure.

D.compressor development report with details for all the strata in triplicate.

E.acceptance test certificate for clear sounding of tube well and site properly levelled and cleaned and cavity around the tube well duly packed with clay and certificate for well cap, bore pipe, clamp, wooden slipper, earthing terminal and half coupling on the top of the pipe.

F.after the tube well has been completed each joint of housing pipe, blind pipe and that of strainer will both screwed type and continus type welded with 2 nos. M.s. flats of size overlapping by 6" on either side by socket.

ANNEXURE -I

(STRATA TABLE)

NAME OF AGENCY :

LOCATION OF TUBE/BORE WELL :

STRATA CHART

Signature of Bidder



DEPTH DRILLED

SIZE OF BORE

HOUSING PIPE

BLIND PIPE

STAINLESS STEEL SCREEN

SLOT SIZE

GRAVEL PACKING

BAIL PLUG

REDUCER

HOUSING CLAMP

CENTERING GUIDES

WELL CAP

TOTAL HOURS DEVELOPED

STATIC WATER LEVEL

YIELD

DRAWN DOWN

AQUIFER WATER LEVEL

REMARKS IF ANY.

ENGINEER - IN - CHARGE.

RATES ARE INCLUDING

Carrying out geological and hydrogeological investigation to understand the deposition pattern of geological layers and assess the groundwater potential and identify available lithology of the particular location/ point with probable formation material with depth / thickness of the layer along with approximate permeability and transmissivity of specific material to calculate water bearing capacity and rainwater recharge capacity by following methods:

Signature of Bidder



(Geophysical Survey Involving Earth Resistivity Principals Vertical electrical sounding using Schlumberger 4 Electrode Array)

Carrying out geological and hydrogeological investigation to understand the deposition pattern of geological layers and assess the groundwater potential and identify available lithology of the particular location / point with probable formation material with depth / thickness of the layer along with approximate permeability and transmissivity of specific material to calculate water bearing capacity and rainwater recharge capacity by following methods.

(Geomagnetic Survey by using TESLA 6 ground water detector or similar equipment working on magnetotellurics 6 channel detection method)

Required Excavation for pits and trenches for Filtration chamber 2.5MX2.5mX3M in soil of required width, length and depth for the rainwater harvesting system in all types of soil, sand, gravel, clay, soft and hard Murom including removing all excavated material within the premises up to 100 meter lead, cleaning of site, removing shrubs, tree roots, vegetation and dewatering if required as per site condition, back filling, ramming, watering for depth up to 3.0 m as per the approved design/ drawing and specifications.

Providing and laying 150mm thick plain cement concrete 1:4:8 for base of the system using graded stone aggregate of 40 mm and below size including necessary formwork at various locations, including mixing, laying, consolidation, finishing, curing & dewatering the pits etc. all as per drawings, specifications and as directed.

Providing, fixing, testing and commissioning of readymade and light weight Polyethylene (PE) material rainwater harvesting system with HDPE ladder specially designed for underground application to absorb surrounding dynamic load having adequate water conveying capacity to function as primary surface filtration unit / secondary surface filtration unit having filter media up to 300 to 500 mm height in required shape/ size to achieve an effective sedimentation process connecting storm water drainage having as per manufacturer guidelines and approved design/ drawings with following specifications, 1000 mm dia x 1800 mm deep x 8 mm thick for Regarge well & Storm water reuse filtration

Providing, fixing and commissioning of readymade 600MM X 600MM Clear opening FRP recess manhole cover with frame adjustable to filtration chamber for the system specially designed with locking arrangement for various load bearing capacities for vehicular or nonvehicular movement suitable to application to be fixed to primary/ secondary filtration systems as per manufacturer guidelines and approved design/ drawings.
5 T load carrying capacity.

Providing, laying and fixing in position unplasticised rigid PVC pipes conforming to IS: 4985 (working pressure 6 kg/Sqcm) including all fittings such as bends, clamps to the specified invert levels and slope with provision of water meter fixing arrangement supported by sand filled bags, including all fittings such as NRV, bends, junctions, Tee, air vent, end-cap, flange adapters, in-situ adapter, access pieces/plugs jointing with uPVC adhesive including cutting holes and making it good water tight by using specially designed leak proof flange adapters joining, testing & commissioning of overall 10 meter pipe length for sub-surface filtration system as per design/ drawing as approved.
110 mm dia. For Recharge well

Supply, installation, testing and commissioning of smart water management system to collect real time water quantity parameters for conductive liquids like rainwater for underground application to be fixed in-line horizontal uPVC pipe having weather proof connection, with data logging device having IP68 housing with required isolated flow signal with paddle wheel flow sensor, microprocessor based transmission option for flow pattern recording with GSM / GPRS modern interface feature including 10 meter long cable for 12-24V DC power supply and 12V 3500mAh battery capacity, communicate all data to BMS, BMS Compatible including all necessary fixing arrangement as per design/ drawing as approved.



Flow meter

Supply, installation, testing and commissioning of smart water management system to collect real time water quantity parameters for conductive liquids like rainwater for underground application to be fixed in-line horizontal uPVC pipe having weather proof connection, with data logging device having IP68 housing with required isolated flow signal with paddle wheel flow sensor, microprocessor based transmission option for flow pattern recording with GSM / GPRS modem interface feature including 10 meter long cable for 12-24V DC power supply and 12V 3500mAh battery capacity, communicate all data to BMS, BMS Compatible including all necessary fixing arrangement as per design/ drawing as approved.

Centralized Monitoring along with third party API (Application Program Interface) integration

Supplying and fixing two sets of four stage filtration arrangement on inlet and outlet pipes using suitable material to be fixed on uPVC pipe with SS clamp as per approved drawing/ design. For Sotrm water Recharge & Reuse Filtration system

Drilling and reaming bore hole at site using appropriate drilling methodology such rotary, semi rotary, DTH as suitable to site geology up to designed depth by bentonite or mud flushing of the borehole including suppling, loading, unloading and filling of sticky clay balls of size 25mm to 50mm and gravel packing in surrounding gaps while developing of each water bearing zones by using required capacity of air compressor including required machineries, equipment's, safety measures as per approved design/ drawing and direction of site engineer.

Rate inclusive of creating pit for drilling process, if required and removal of mud by mud tankers or any other way suitable to site condition, obtain bore-log report from govt. authorized agencies

450 mm dia bore hole

Providing, laying and fixing in position solid uPVC Casing pipe having minimum 6 kg/ sqcm pressure rating including all leakproof fittings jointing with uPVC adhesive including joining, testing & commissioning as per approved design/ drawing.

160 mm dia with solid CM grade casing pipes.

Providing, laying and fixing in position solid uPVC Casing pipe having minimum 6 kg/ sqcm pressure rating including all leakproof fittings jointing with uPVC adhesive including joining, testing & commissioning as per approved design/ drawing.

160 mm dia with perforated CM grade casing pipes.

8.0 CHLORINATED POLYVINYL CHLORIDE (CPVC) PIPES

CPVC pipes & fittings used in hot & cold potable water distribution system shall conform to requirement of IS 15778. The material from which the pipe is produced shall consist of chlorinated polyvinyl chlorides. The polymer from which the pipe compounds are to be manufactured shall have chlorine content not less than 66.5%.

The internal and external surfaces of the pipe shall be smooth, clean and free from grooving and other defects. The pipes shall not have any detrimental effect on the composition of the water flowing through it.

Notes

For CPVC pipes SDR is calculated by dividing the average outer diameter of the pipe in mm by the minimum wall thickness in mm. If the wall thickness calculated by this formula is less than 1.52 mm, it shall be increased to 1.52 mm. The SDR values shall be rounded to the nearest 0.5.

Dimensions of Pipes



The outside diameter, outside diameter at any point and wall thickness shall be as given in Table 18.16.

Diameter

The outside diameter and outside diameter at any point as given in Table 18.16 shall be measured according to the method given in IS 12235 (part 1).

Diameter at any point

The difference between the measured maximum outside diameter and measured minimum outside diameter in the same cross-section of pipe (also called tolerance on ovality) shall not exceed the greater of the following two values

- (a) 0.5 mm, and
- (b) 0.012 dn rounded off to the next higher 0.1 mm.

Wall Thickness

The wall thickness of the pipes shall be as given in Table 18.16. Wall thickness shall be measured by any of the three methods given in IS 12235 (part 1). To check the conformity of the wall thickness of the pipe throughout its entire length, it is necessary to measure the wall thickness of the pipe at any point along its length. This shall be done by cutting the pipe at any point along its length and measuring the wall thickness as above. Alternatively, to avoid destruction of the pipe, nondestructive testing methods such as the use of ultrasonic wall thickness measurement gauges shall be used at any four points along the length of the pipe.

Tolerance on Wall Thickness

- (a) For pipes of minimum wall thickness 6 mm or less, the permissible variation between the minimum wall thickness (e_{Min}) and the wall thickness at any point (e), ($e - e_{Min}$) shall be positive in the form of $+y$, where $y=0.1 e_{Min}+0.2$ mm.
- (b) For pipes of minimum wall thickness greater than 6mm, the permissible variation of wall thickness shall again be positive in the form of $+y$, where y would be applied in two parts.
- (c) The average wall thickness shall be determined by taking at least six measurements of wall thickness round the pipe and including both the absolute minimum and absolute maximum measured values. The tolerance applied to this average wall thickness from these measurements shall be within the range $0.1 e_{Min}+0.2$ mm (see Table 18.16).
- (d) The maximum wall thickness at any point shall be within the range $0.15e_{Min}$ (see Table 18.16).
- (e) The results of these calculations for checking tolerance shall be rounded off to the next higher 0.1 mm.

Effective Length (Le)

If the length of a pipe is specified, the effective length shall not be less than that specified. The preferred effective length of pipes shall be 3, 5 or 6 m. The pipes may be supplied in other lengths where so agreed upon between the manufacturer and the purchaser.

Pipe Ends



The ends of the pipes meant for solvent cementing shall be cleanly cut and shall be reasonably square to the axis of the pipe or may be chamfered at the plain end.

Physical and Chemical Characteristics

Visual Appearance: The colour of the pipes shall be off-white. Slight variations in the appearance of the colour are permitted. The internal and external surface of the pipe shall be smooth, clean and free from grooving and other defects.

Opacity: The wall of the plain pipe shall not transmit more than 0.1 per cent of the visible light falling on it when tested in accordance with IS 12235 (Part 3).

Effect on Water: The pipes shall not have any determinate effect on the composition of the water flowing through them, when tested as per 10.3 of IS 4985.

Reversion Test: When tested by the method prescribed in IS 12235 (Part 5/ Sec 1 and Sec 2), a length of pipe 200 ±20 mm long shall not alter in length by more than 5 per cent.

Vicat Softening Temperature: When tested by the method prescribed in IS 12235 (part 2), the Vicat softening temperature of the specimen shall not be less than 110°C.

Density: When tested in accordance with IS 12235 (Part 14), the density of the pipes shall be between 1450kg/m³ and 1650kg/m³.

Mechanical Properties

Hydrostatic Characteristics: When subject to internal hydrostatic pressure test in accordance with the procedure given in IS 12235 (part 8/Sec 1), the pipe shall not fail during the prescribed test duration. The temperatures, duration and hydrostatic (hoop) stress for the test shall conform to the requirements given in Table 18.17. The test shall be carried out not earlier than 24 h after the pipes have been manufactured.

**TABLE 18.17
Requirements of Pipes for Internal Hydrostatic Pressure Test
(Clause 18.9.5.1)**

Sl. No.	Test	Test Temperature Min	Test Period	Hydrostatic (Hoop) Stress
		°C	h	MPa
(1)	(2)	(3)	(4)	(5)
(i)	Acceptance	20	1	43.0
(ii)	Type	95	165	5.6
(iii)	Type	95	1000	4.6
(iv)	Type	95	8760	3.6 (Test for thermal stability)

Thermal Stability by Hydrostatic Pressure Testing: When subject to internal hydrostatic pressure test in accordance with the procedure given in IS 12235 (Part 8/Sec 1) and as per requirement given in Table 18.17, Sl. No. (iv), the pipe shall not burst or leak during the prescribed test duration.

Resistance to External Blow at 0°C: When tested by the method prescribed in IS 4985, with classified striker mass and drop height as given in Table 18.18, the pipe shall have a true impact rate of not more than 10 per cent.



TABLE 18.18
Classified Striker Mass and Drop Height Conditions for the Falling Weight Impact Test
(Clause 18.9.5.3)

Sl. No.	Nominal Pipe Size	Mass of Falling Weight	Falling Height
	mm	Kg	mm
(1)	(2)	(3)	(4)
(i)	15	0.5±0.5%	300±10
(ii)	20	0.5±0.5%	400±10
(iii)	25	0.5±0.5%	500±10
(iv)	32	0.5±0.5%	600±10
(v)	40	0.5±0.5%	800±10
(vi)	50	0.5±0.5%	1000±10
(vii)	65	0.8±0.5%	1000±10
(viii)	80	0.8±0.5%	1200±10
(ix)	100	1.0±0.5%	1600±10
(x)	150	1.6±0.5%	2000±10

Flattening Test: When tested by the method prescribed in IS 12235 (part 19), pipe shall show no signs of cracking, splitting and breaking.

Tensile Strength: When tested by the method prescribed in IS 12235 (Part 19), the tensile strength at yield shall not be less than 50 MPa at 27 ± 2°C.

Sampling and Criteria for Conformity

The sampling procedure and criteria for conformity shall be as given in Annexure F.

Marking

Each pipe shall be clearly and indelibly marked in ink/paint or hot embossed on white base at intervals of not more than 3 m. The marking shall show the following:

- Manufacturer's name or trademark
- Outside diameter,
- Class of pipe and pressure rating, and
- Batch or lot number

BIS Certification Marking: Each pipe may also be marked with the Standard Mark.

Fittings

The fittings shall be as follows.

- Plain CPVC solvent cement fittings from size 15 mm to 160 mm.
- Brass threaded fittings.
- Valve from size 15 mm to 160 mm
- Brass Threaded Fittings: All types of one end brass threaded male/female adaptors in various fittings like coupler, socket, elbow, tee is available for transition to other plastic/metal piping and for fixing of CP fittings. Ball, Gate valves in CPVC are available in all dimensions. All fittings shall carry the following information:
 - Manufacturer's name/trademark.
 - Size of fitting.

Piping Installation Support and Spacing



Concealed Piping

Pipes can be concealed in chases. The pipes and fitting are to be pressure tested prior to concealing the chases. To maintain alignment of CP fittings while joining, all alignment of fittings and pipe shall be done correctly. **DO NOT USE NAILS FOR HOLDING OF PIPES IN THE CHASES.**

External Installations

For pipes fixed in the shafts, ducts etc. there should be sufficient space to work on the pipes. Pipes sleeves shall be fixed at a place the pipe is passing through a wall or floor so as to allow freedom for expansion and contraction. Clamping of the pipe is done to support it while allowing the freedom for movement.

All pipes exposed to sunlight shall be painted with a water based acrylic paint emulsion to enhance UV protection. Pipes in trenching shall be laid in accordance to the Good Plumbing practices followed for Metal piping.

Recommended Support Spacing (Distance between Pipe Clamps Horizontal Support)

Pipe Size	Horizontal Support (In meters)			
	Temperature			
	23°C	38°C	60°C	82°C
16 mm (1/2")	1.22	1.22	1.07	0.92
20 mm (3/4")	1.53	1.37	1.22	0.92
25 mm (1/0")	1.68	1.3	1.37	0.92
32 mm (1 1/4")	1.83	1.68	1.53	1.22
40 mm (1 1/2")	1.98	1.83	1.68	1.22
50 mm (2")	2.29	2.14	1.98	1.22

Expansion LOOP

CPVC systems, like all piping materials, expand and contract with changes in temperatures. CPVC pipes shall expand 7.5 cm per 30 m length for a 400C temperature change. Expansion does not vary with Pipe size. Thermal expansion can generally be accommodated at changes in direction. On a long straight run, an offset or loop based on the following chart is required.

Nominal Pipe Size	Length of Run (Meter), Loop length in cms.				
	6 metre	12 metre	18 metre	24 metre	30 metre
15 mm	43	56	69	79	86
20 mm	48	66	81	91	104
25 mm	53	74	91	104	117
32 mm	58	81	102	117	130
40 mm	63	89	109	127	142
50 mm	71	102	124	145	63

Testing

All water supply systems shall be tested to hydrostatic pressure test. The pressure tests are similar to the test pressure used for other plastic/metal pipes. System may be tested in sections and such section shall be entirely checked on completion of connection to the overhead tank or pumping system or mains.

Measurements



The net length of pipes as laid or fixed shall be measured in running meters correct to a cm for the finished work, which shall include CPVC pipe and fittings including plain and Brass threaded fittings and jointing solvent cement.

9.0 PLUMBING INSULATION FOR HOT WATER SUPPLY

Scope:

The scope of this section comprises the supply and fixing of insulation conforming to these specifications and in accordance with requirement of Bill of quantities.

MATERIAL: Closed Cell EPDM Rubber

Thermal insulation material for Pipe insulation shall be closed cell Elastomeric EPDM Rubber. The Thermal conductivity of the insulation material shall not exceed 0.038 W/moK at an average temperature of 32oC. Density of the EPDM rubber shall be 40-60 Kg/m³. The product shall have temperature range of -57 oC to 125oC. The insulation material shall be fire rated for Class V 0 as per UL 94. The flammability and smoke density shall be 25/50 as per ASTM E 84, Non flammable as per JIS K 6911, Australian standard 1530 and class 5.3 as per EMPA. Water vapour diffusion resistance factor(μ) \geq 7000. The water absorption (weight%) shall not exceed 5 as per ASTM D 1056. The insulation material should be free from Nitrosamine contents as per US FDA norms. It should be CFC free. It should not be corrosive to copper and stainless when tested as per DIN 1988. The material should not develop crack when tested for ozone resistance as per ASTM 1149. The % shrinkage (Heat Stability) should not exceed 6 when tested as per ASTM C 534(93oC, 7 days). No cracks should develop when exposed to UV (accelerated weathering resistance test cycle UVB-313 at 60 oC/8h, CON at 50 oC/4h) as per ASTM G 154-04. The resistance to microbiological growth should be in accordance to UL 181 – and meet the acceptance criteria of resistance to fungal contamination as per ASTM G21. It should meet the acceptance criteria of resistance to bacterial contamination as per ASTM 2180.

Thickness of the insulation shall be as specified for the individual application. Each lot of insulation material delivered at site shall be accompanied with manufacturer's test certificate for thermal conductivity values, density, water vapour resistance factor, Nitrosamine content, Heat stability and fire properties. Samples of insulation material from each lot delivered at site may be selected by Owner's site representative and gotten tested for thermal conductivity and density at Contractor's cost. Adhesive used for sealing the insulation shall be modified neoprene contact adhesive with minimum bond strength of 1.25 kg/m². It should have high water vapour resistance, good weathering properties and self-extinguishing once dried strictly as per manufacturer's recommendations.

1.1 HOT WATER SUPPLY & RETURN PIPING INSULATION

Insulation Material Technical Specification - Anti-bacterial and anti-fungal Closed Cell Elastomeric Foam made from EPDM rubber with self-bonded olefin (HDPE) covering

Material: EPDM
Density: 40-60 kg/m³
Thickness: 25 mm

A. Closed Cell EPDM Rubber

- Thermal conductivity of elastomeric foam shall not exceed 0.035 W/ (m*K) at an average mean temperature of 24o C (Tested acc. To ASTM C177)
- Material shall be anti-fungal and shall pass resistance to Fungi test in accordance with UL181.



- Material shall be anti-Bacterial and shall pass bacterial resistance test in accordance with ASTM E2180-01.
- Material shall have fire class A (Flame spread: 20 & Smoke developed index 150) in accordance with ASTM E 84.
- It shall have rate of burning (horizontal position) test in accordance with part-2 ASTM D635-06.
- Material shall have flammability class V-0 in accordance to UL94.
- Material shall be non-corrosive for copper and stainless steel in accordance with DIN 1988.
- The material is Dust and Fibre Free
- Unlike other generic materials it shall be self-extinguishing, does not drip fireballs and does not spread flames
- It shall have Moisture Diffusion Resistance Factor or 'μ' value minimum 7,000 per EN 12086 without any outer facing
- Material shall be CFC/HCFC free and tested in accordance with USEPA 5021A/USEPA8260C
- Density of material shall be 40-60 kg/m³ in accordance to ASTM-D-1667.
- Material shall have service temperature range -50°C to +125°C.
- Material Color: Black

B. Self-bonded polyethylene Fibre Cloth

- High density polyethylene fibre cloth bonded with moisture control metal foil films attached with high strength self-adhesive with silicone releasing paper.

Material : High Density Poly olefin Fibre Cloth

Thickness : 0.2mm

- It shall have good UV protection and water repellent property which enhances system life.
- The opacity of product shall be 0.16% as per ASTM D1746.
- It shall have 4.23 ng/cm² water vapour permeability as per IS 101: part 6.

C. Fibre Glass Cloth

- Material is acrylic based woven fiberglass fabric made from E glass having excellent combination properties of high strength & moisture resistance.

Material : Fibre Glass Cloth

Thickness : 0.19mm

- It shall acrylic PSA type adhesive.
- It shall have E glass type fiber.
- Base fabric mass shall be 225 ± 5% GSM
- Total mass shall be 280 ± 5% GSM

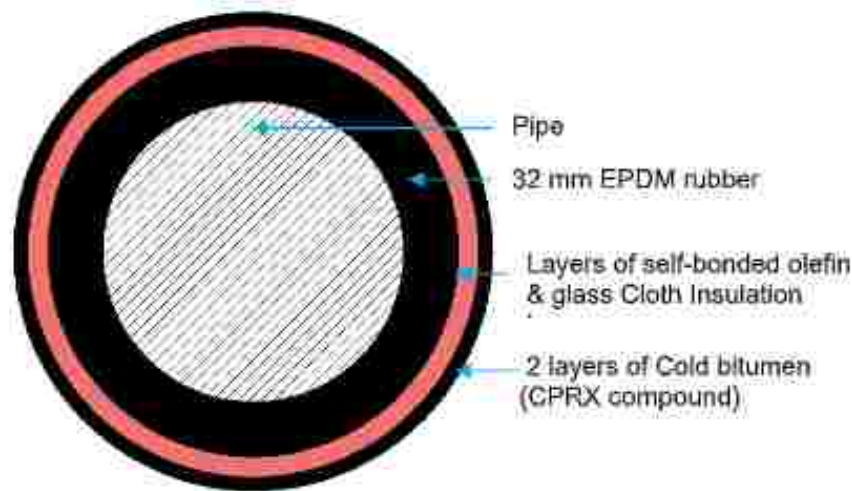

Specifications Self bonded olefin (HDPE) for Outer covering of Insulation Material

- It is HDPE fiber cloth bonded with moisture control metal foil film.
 - It has good UV resistance and water resistance property.
- It has high water vapour diffusion resistance and low thermal conductivity

1.2 Method of Measurement for Insulation:

Unless otherwise specified measurement for pipe insulation for the project shall be on the basis of centre line measurements described herewith

- a. Pipe Insulation shall be measured in units of length along the centre line of the installed pipe, strictly on the same basis as the piping measurements described earlier. The linear measurements shall be taken before the application of the insulation. It may be noted that for piping measurement, all valves, orifice plates and strainers are not separately measurable by their number and size. It is to be clearly understood that for the insulation measurements, all these accessories including cladding, valves, orifice plates and strainers shall be considered strictly by linear measurements along the centre line of pipes and no special rate shall be applicable for insulation of any accessories, fixtures or fittings whatsoever.

10.0 SWR - UPVC PIPES & FITTINGS

Soil, waste, vent SWR Ring Fit/Solvent pipes with socket and spigot. All pipes shall be straight and smooth and inside free from irregular bore, blow holes, cracks and other manufacturing defects. These pipes conform to EN 1329 / IS 13592 (SWR type B) and are designed to withstand continuous internal hydraulic pressure of 6 Kg/cm so as to ensure life-long trouble-free working. The pipes are provided with an integral rubber ring type socket at one end while the other end is kept plain, smooth and free from burrs. Rubber ring type socket ends provide easy push – fit type jointing. Simultaneously, allowance for thermal expansion can also be provided during installation.

Fittings:

Fittings shall conform to the corresponding Indian Standard as for pipes. Contractor shall use pipes and fittings of matching specification/manufacturer standard.



Access door shall be secured air and watertight with 3mm thick insertion rubber washer and white lead. The bolts shall be lubricated with grease or white lead for easy removal.

Fittings shall be of the same make as that of pipes, injection moulded and shall conform to Indian Standard.

Jointing:

The jointing of the pipes to the fittings shall be done as per the manufacturer's instructions / recommendation. The rubber ring socket fittings and pipes shall be jointed as follows:-

Clean the outside of the pipes spigot end and the inside of the ceiling groove of the fitting.

Apply the lubricant uniformly to the spigot end, sealing ring and pass the spigot end into the socket containing sealing ring until fully home. Mark the position of the socket edge with pencil or felt open on the pipe, then withdraw the pipe from the socket by approximately 10 mm to make the pipe fully fitted to the fitting. The horizontal pipes on the wall shall be fixed with M.S. fabricated clamps with necessary provisions to take care the expansion and contraction in PVC pipes.

Rubber Seal Rings for Joints & Access Doors : Manufactured in accordance with IS : 5382 for 75 mm / 90 mm / 110 mm sizes. These are made out of natural rubber with a shore 'A' hardness of 40 × 5. Provide superior resistance to biological attack. Special design of cross section ensures perfect sealing.

Lubricant: Available in 100 gms, 250 gms & 500 gms packing. Specially formulated for compatibility with rubber seal as well as PVC. Does not support the growth of bacteria or fungi.

Pipe, Hangers, Support, Clamp, Bracket etc.:

Supports:

The spacing of the clamps shall be at the intervals of 1.5 mtr to 2 meter depends on the requirement of the supporting arrangements.

Pipes shall be aligned properly before fixing them on the wooden plugs with clamps. Even if the wooden plugs are fixed using a plumb line, pipe shall also be checked for its alignment before clamping, piping shall be properly supported on, or suspended from clamps, hangers as specified and as required. The Contractor shall adequately design all the brackets, saddles, anchors, clamps and hangers and be responsible for their structural sufficiency. Pipe supports shall be primer coated with rust preventive paint.

Testing:

Before the system is put into use, it should be tested for leakages by air test, hydraulic test or smoke test.

11.0 BALL VALVES (FLOAT VALVE):

The ball valve shall be of high-pressure class and shall be confirm to IS: 1703 of sizes as specified. The nominal size of a ball valve shall be that corresponding to the size of the pipe to which it is fixed. The ball shall be of brass or gun metal as specified and the float shall be of polythene sheet. The minimum gauge of copper sheet used for making the float shall be 0.45mm for float up to 115mm dia and 0.55mm for float exceeding 115mm dia and shall be special in shape. The valve shall be constructed to permit replacing without console of the valve body from the valve line and the system shall not blow out under pressure. The jointing of the float shall be made by efficiently burnished, lapped and soldered seam or by bracing. Plastic float may also be used if specified. The body of ball valve when assembled in



working conditions with the float immersed to not more than half of its volume shall remain closed against a test pressure of 10.5 Kg/Sq.cm. All ball valves shall be capable of withstanding a pressure of 14 Kg/Sq.cm.

The ball valve shall generally conform to IS specifications NO. 1703-2000

Providing and fixing float valve with pressure type PTMT float valve.

12.0 BUTTERFLY VALVES

- Butterfly valves as per IS - 13095 / 1991
- SCOPE - Fabricated valve will not be considered.
- This standard cover double flanged and wafer type of metal seated, resilient seated cast iron, ductile iron, and carbon steel and lined butterfly valves for general purpose. Valves covered under this standard are manually, pneumatically, hydraulically or electrically operated.
- It covers valves of nominal pressure designations up to and including 4 MPa. and class 300 with ends flanged in accordance with appropriate table of I.S 6418: 1971 'Cast iron and malleable cast iron flanges for general engineering purpose' or wafer type valves with bodies designed to be accommodate between pipe work flanges in accordance with appropriate table of IS 6418 : 1971 or IS 6392 : 1971 'steel pipe flanges' in nominal size DN 40 to DN 2000. It also covers valves up to class 300 and flanges as per the pressure/temperature ratings given in IS 13159 (Part 1) : 1991 'steel pipe flanges and flanged fittings : part I dimensions' and IS 6418 : 1971 'cast iron and malleable cast iron flanges for general engineering purposes.
- **REFERENCE**
 - The applicable Indian standards are necessary adjuncts to this standard.
- **TERMINOLOGY AND DEFINITIONS**
 - Terminology and definition covered in IS 4854 (Part3) : 1974 are generally applicable.
- **VALVE END CONNECTIONS**
 - Double flanged valves
 - A valve having flanged ends for connection to pipe flanges by individual bolting.
 - Water valve
 - A valve for clamping between two pipe flanges using through bolting this may be single flange, lug type, U- section or flangeless type.
- **SERVICE APPLICATIONS**
 - Valves shall be suitable for one or more of the following applications:
 - Tight shut off - A valve having no visible leakage past the disc in closed position under test conditions.
 - Regulating - A valve intended for regulating purpose and which may have a clearance between the disc and the body in close position.
 - Low leakage - A valve which has specified maximum leakage rate past the disc in the closed position.



- **VACUUM CONDITION**
 - Where valve are to be used under vacuum conditions, purchaser shall mention specifically and the detailed design provision shall be mutually agreed between the purchaser and the manufacturer.

- **NOMINAL SIZES**
 - The range of nominal valve size (DN) in mm shall be as follows:
 - 40,50,65,80,100,150,200,250,300,350,400,450,500,600,700,800,900,1000,1200,1400,1600,1800 and 2000

- **NOMINAL PRESSURES**
 - Valve shall be designated by nominal pressure (PN) defined as the maximum permissible working pressure (Mpa) at 20 0 C temperatures as follows:
 - PN 0.25, PN0.6, PN1.0, PN1.25 and PN4.0.
 - The class designation for valves specified by nominal pipe size shall be class 125, class 150 and class 300.

- **PRESSURE/TEMPERATURE RATINGS**
 - Maximum permissible gauge working pressure and operating temperatures shall be in accordance with IS 6418 : 1971 and IS 13159 (Part I) : 1991 except that restriction on temperature may be placed by the manufacturer on valves in accordance with this standard by reason of valve type, trim materials or other factors. However, all valves shall be suitable for continuous use at their PN designation within the temperature range of -10⁰ c to 65⁰ c.

- **BODY ENDS**
 - Double Flanged Body Ends
 - The dimensions of flanged body ends and drillings shall be in accordance with the requirement given in Annex B. Flanges as per any other specific requirements of the purchaser may also be given as agreed to between the manufacturer and the purchaser or as per IS. 13159 (part I) : 1991.
 - Flanges shall be at right angles to the axis of the bore and concentric with the bore.
 - Flanges shall be drilled unless otherwise specified and bolt holes shall be off centers. Tapped by the design of the valve.
 - Wafer Body Ends
 - Body ends shall be capable of being fitted between the pipe flanges complying with the requirements of annex B flange drilling.
 - The joint faces shall be at right angles to the axis of the bore and concentric with the bore.
 - Holes may be provided, where required by the design, for the passage of the bolts securing the flanges and the valve. Where through bolting is not practicable due to the presence of valve shaft, bearing housing, tapped holes may be provided for individual bolting of each flange.

- **FACE TO FACE DIMENSIONS**
 - Face to face dimensions of double flanged and wafer types of valve shall be as per Table 1.
 - Face to face dimensions given in Table 1 are exclusive of the sealing gaskets at both ends.
 - The manufacturer shall ensure that adequate space will be available between valve flanges for bolting when flanged valve with short body face to face to face or wafer long face to face are manufactured.

 - Tolerance on face to face dimension in Table 1 shall be as follow.



o

Face to face dimension of Unlined valve MM		Tolerance MM
Over	Up to and including	
0	250	+2
250	500	+3
500	800	+4
800	1000	+5
1000	2400	+6

- **BODIES**

- Bodies end ports shall be circular and the numerical valves of the diameter shall be as close as possible to the valve of DN.

- **DISC AND SHAFT**

- o The disc and shaft shall be designed to withstand the maximum pressure differential across the valve in either direction of flow. The shaft may be of one piece design or in two pieces separately attached to the disc. Any means of attachment between the shaft and the disc shall be such as to preclude components becoming loose in service.

- **SEATING AND LININGS**

- o Non-integral seating, and lining where used, and their means of attachment shall be such as to preclude their becoming loose in service.

- **BEARINGS**

- o The bearings shall be suitable for the maximum loads imposed by the shaft during testing and in service.
- o For valves DN 350 and above, a bearing shall be provided to take the axial thrust, spring retaining clips (cir clips) shall not be used as thrust bearing.
- o Suitable sealing shall be provided for the shaft where it passes outside the pressure containing enclosure.

- **MATERIALS**

- o This standard is based on materials specified in Table 2. Unless otherwise agreed, the materials shall be of a grade equivalent to those given in Table 2 or superior. Other material may be used as per agreement between the manufacturer and the purchaser.

- **OPERATION**

- o Manual Operation
- All valves shall be capable of operated at a differential pressure across the disc as marked on the valve. Lever, worms gear/traveling nut type or any other suitable type of operator can be used.
 - o Direction
- Unless otherwise, specified manually operated valves shall be closed by turning hand wheel or lever in a clockwise direction when facing the hand wheel or lever. The design of lever when fitted shall be such that the lever may only be assembled to the valve so that it is parallel to the direction of flow when the valve is open.
- All gear traveling nut operators shall be provided with suitable stops to prevent movement of the shaft beyond the limit corresponding to the fully closed position of the disc.



- All gear traveling nut operators shall be packed with grease for life time operation. Gear/traveling nut operators shall be totally enclosed and weather proof for general application. For special applications such as marine, submerged service etc. The purchaser may specify special en-closer.
- All gear/traveling nut operators shall be self locking type. All lever operated valve shall be capable of being locked at least three intermediate position.
- The operating hand-wheels shall be marked 'CLOSE' or 'SHUT' to indicate the direction of closer.
- The operator shall be provided with arrangement to indicate the disc position.
- **TESTING**
 - All valves shall hydrostatically tested by the manufacturer before dispatch. The pressure shall be obtained without any significant hydraulic shock. Testing shall be carried on before application of paint or other similar treatment unless otherwise agreed between the purchaser and the manufacturer. There shall be no air entrapped within the part of the valves subjected to test pressure.
- **PERFORMANCE TESTING**
 - Each valve shall be shop operated from fully closed to fully open position and reverse, under no pressure and no flow condition to demonstrate that the complete assembly is workable.
- **BODY TEST**
 - Completely assembled valve shall be tested as follows:
 - 'The body ends shall be blanked so that the valve is subjected to the full pressure in all directions include by the test pressure wafer valves may be tested in any suitable manner agreed between the purchaser and the manufacturer. The valve disc shall be in slightly open position and pressure equivalent to 1.5 times the maximum permissible working pressure shall be applied with water. The duration of this test shall be as in Table 3.'
- **SEAT TEST**
 - The seating surface of the valve shall be cleaned unless a surface treatment forms an integral part of the design or the use of a temporary surface treatment has been agreed between the manufacturer and the purchaser to avoid the possibility of damage under the condition of the test.

TABLE-3

Nominal DIA MM	Minimum test duration in minutes	
	Body Test	Seat test when applicable
Up to and including 50	0.25	0.25
65 to 150	1.0	1.0
200 to 300	2.0	2.0
350 to 1000	5.0	2.0
1200 to 2000	5.0	3.0

- Each valve shall be shop tested for leaks in close position. The test shall be conducted with the body flanges in a horizontal position. Pressure shall be applied to the upstream end of the valve, the downstream being open to atmosphere. The duration of test shall be as per Table 3. There shall be no indication of leakage past the valve disc during test and valves shall be drop tight. Seat test shall be carried out in both the direction of valve if agreed



between the manufacturer and the purchaser. The seat pressure applied on upstream side shall be equivalent to 1.1 times the maximum permissible working pressure at 20° c and shall be applied with water.

- o For regulating type valves seat test shall not be applicable.

• DISC STRENGTH TEST

- o The test shall be conducted with the body flanges in horizontal position. The test pressure shall be 1.5 times the maximum permissible pressure at 20 0 C With disc in closed position, hydro test pressure shall be applied to the lower face of the disc for duration as per table-3. There shall be no damage to the valve disc nor shall any part of valve or disc be permanently deformed by the test. The purpose of this test is to provide evidence of the adequacy and structural integrity of disc and body. Any leakage past the seat shall not be the criteria for rejection of the valve (Sampling test sample as per IS 2500). For regulating type valves, disc strength shall not be applicable.
- o Maximum permissible leakage shall be as per table 4.

• TEST CERTIFICATES

- o When specified by the purchaser, the manufacturer shall issue a test certificate conforming that the valves have been tested in accordance with this standard and stating the actual pressures and medium used in the test.

TABLE 4	
VALVE TYPE	LEAKAGE RATE
Tight shut-off	No visible leakage for duration of test
Low leakage	0.1 mm ² /s X DN (sec 5)
Regulating	Not specified. Outside the scope of this standard.

• INSPECTION

- o If inspection is required, this shall be stated in the enquiry/order. The purchaser or his authorized representative shall have access to the manufacturer's works at all reasonable times to inspect assembled valve to his order.

• WITNESSING OF TESTS

- o When the purchaser desires to witness the tests, this shall be specifically agreed in advance.

• MARKING

- o Marking shall be cast integral on the body or on a plate securely attached to the body. The markings shall be in accordance with I.S. 9866: 1981.

• PREPARTION FOR DESPATCH

- o Valve shall be complete in all respect when shipped. Each valve shall be drained, cleaned, prepared and suitably protected with 2 coats of red oxide on un machined surfaces and rust preventive coats on machined and flanged surfaces for dispatch in such a way as to minimize the possibility of damage and deterioration during transit and storage. Painting other than specified on the finished valve shall be as per the agreement between the manufacturer and the purchaser.
- o Disc shall be unseated when dispatched, but care shall be taken to ensure that there is no risk of damage to the disc.
- o When specified, the body ends shall be suitably sealed to exclude foreign matter during transit and storage.



- o Components shipped unattached shall be adequately protected and identified to permit correct field assembly.

13.0 FLOT VALVE

Float valve with pressure PN 10 type PTMT float valve.

14.0 REFLUX VALVE (NON-RETURN VALVE)

Specifications shall conform to IS – 5312 or its latest update.

Materials

The materials used for the manufacture of different component parts shall conform to the requirements given in IS 5312 – 2004 or its latest update.

Materials of Construction

Sr. No.	Component	Material
(a)	Body, cover, door, bearing holder and Doors/Disc/Plate	Grey Cast Iron: IS 210 Gr. FG 260
(b)	Hinge Pin/ Door Pin and Door Suspension pin	Stainless steel, IS 6603
(c)	Body Seat rings	Leaded tin bronze, IS 318
(d)	Door Face ring	Leaded tin bronze
(e)	Bearing Bushes / Bearing Block	Leaded tin bronze
(f)	Plugs for hinge pin/ Air release plug	Leaded tin bronze
(g)	Bolts	Carbon Steel, IS 1363
(h)	Nuts	Carbon Steel, IS 1363
(i)	Gaskets	Rubber, IS 638
(j)	Hinges	Grey Cast Iron, IS 10

DESIGN AND MANUFACTURE

Body

The body may be made in two parts - inlet shell and outlet shell. The inlet shell shall have duck foot support.

Diaphragm

Diaphragm shall be fitted between inlet and outlet shells. The parts in the diaphragm should be so designed as to induce minimum head loss in the flow through the valve.

Water Way Area

The area of the waterway through the multi- doors in the diaphragm shall not be less than the bore area except that this area may be reduced by not more than 15 percent for any proprietary designs.

Inlet and Outlet Shell Connections

The attachment of the inlet to outlet shell of the body shall be adequate to withstand the appropriate test pressures, service conditions and the mechanical loads encountered in the operation. All valves shall have bolted connection. Size of the bolts or studs shall not be less than 22 mm.

Signature of Bidder



Seats

Seat rings shall be so fitted as to avoid their becoming loose in service. Standard countersunk screws shall not be used. 6.6 Door - The door shall be integral with the hinge and shall have a flat seating face.

Lugs

Suspension lugs shall be cast integrally on the diaphragm plate and shall be of adequate strength.

Number of Doors

The minimum number of doors (discs) in the diaphragm plate shall be two.

B -Pass Connection

By-passes are not standard items on valves to the design, but if required, it is recommended that they shall be made for connection between the inlet and outlet shell of the valve. By-passes shall conform to PN 1 of IS: 780-1984* and the minimum size of the by-pass arrangement shall be as indicated in respective IS.

Coating

All coatings shall be carried out after satisfactory testing of the valves prior to dispatch. All the un-machined ferrous surfaces of the valve (both inside and outside) shall be thoroughly clean, dry and shall be free from rust and grease before painting. All exposed machined ferrous surfaces shall be painted with one coat of aluminium red oxide primer. Two coats of black Japan conforming to Type B of IS 341 or paint conforming to IS9862 or IS2932 shall be applied by brush or spray for exterior application in colour as approved by the purchaser.

Testing

Each valve shall be subjected to following hydrostatic tests as specified in IS.

- a. Hydrostatic Body Test
- b. Hydrostatic Seat Test

Inspection

The purchaser or his authorized representative shall have free access to the works of the manufacturer at all reasonable times to inspect the valve at any stage of manufacture and to reject any material which does not conform to the specified requirements.

Marking

Following information shall be cast on each valve body in raised letter)

- a) Manufacturer's name or trademark.
- b) Nominal pressure of valve (PN1.0 or PN1.6).
- c) Size of valve, mm.
- d) Direction of flow; and
- e) Heat No. of cast.

BIS Certification Marking – Each valve may also be marked with the Standard Mark.

Lowering And Jointing in Position

Signature of Bidder



Supply of Material

Cast iron double-flanged valves with two tailpieces suitable to pipe conforming to the latest relevant IS shall be supplied and carted by the contractor to the site of work including loading, unloading and stacking at site.

The valves and tailpieces shall be examined before laying for cracks and other flaws. They shall be undamaged in all respect.

The valves shall be cleaned before laying.

All grits and foreign materials shall be removed from the inside of the valves before placing.

All the four faces shall be thoroughly cleaned and coated with a thin layer of mineral grease.

The tightening of gland shall be checked with a pair of inside-calipers. Clearance between the top of stuffing box and the underside of the gland shall be uniform all the sides.

Jointing Material

The contractor shall provide all necessary jointing materials such as nuts bolts, rubber packing, white zinc, jute, lead wool etc.

All tools and instruments, which are to be required for installation of sluice valve shall be provided by the contractor.

All jointing materials shall be got approved from the engineer-in-charge before use.

The nuts and bolts shall conform to the relevant IS.

The rubber packing shall conform all specifications as narrated in respective IS.

Installation

The valve shall be lowered into the trench carefully, so that no part is damaged during lowering operation.

If necessary, tailpieces shall be fitted with sluice valve first outside the trench and then lowered into the trench.

The rubber packing shall be three ply and of approved thickness. The packing shall be of full diameter of the flange with necessary holes and the sluice valve bore. It shall be even at both the inner and outer edges.

The flange faces thoroughly greased.

If flange faces are not free, the contractor shall use thin fibers of lead wool.

After placing the packing, nuts and bolts shall be inserted and tightened to make the joint.

The valve shall be tightly closed when being installed to prevent any foreign materials from getting in between the working parts of the valve.

Each flange bolt shall be tightened a little at a time taking care to tighten diametrically opposite bolts



alternatively.

The valve shall be installed in such a way that its Spindle shall remain in truly vertical position.

The other end of tailpiece shall be fitted with pipes so that continuous lines can work.

Extra excavation required for facility of lowering and fixing valve shall not be paid for.

Testing

After installation of valve the same is tested to 1½ times of its test pressure or as specified in the IS.

The joints of valve shall withstand the test pressure of pipelines.

Defects noticed during test and operation of valve shall be rectified by the contractor at his own cost without any extra claim to the entire satisfaction of the Engineer-in-charge.

Measurement and payment

The rate shall be paid as per Schedule of Payment per number of valves fixed and tested as directed.

15.0 Y -STRAINER

Supply, installation, testing and commissioning of CI Y strainer approved make and best quality confirming to latest IS , PN 10.0, with necessary specials, etc. for pump suction header and wherever required, to complete the job.

16.0 GREASE TRAP

Prefabricated Grease separator shall be of HDPE / Polyethylene conforming to EN 1825 / DIN 4040 / 100 suitable for underground/above ground installation with integrated sludge trap, sloped interior base improves cleaning and reduces disposal time, inlet flow calming system and outlet flow regulation device, inlet and outlet interchangeable, slanted twin access covers with quick release odor tight snap closures, inspection window with interior cleaning arm. The contractor shall refer drawings for selection.

Grease separator shall have mix & pump version manually controlled odor free disposal, cleaning and refilling system at touch of button, maintenance free pump for separator cleaning and disposal. includes closure valve for easy pump removal, pump floor mount included with installation hardware and anti-vibration mat, manual hand valve for transfer from cleaning to disposal mode, of adequate pumping capacity, with necessary cabling, top mounted water jet(s) for grease layer breakup and water spray nozzles for interior wall cleaning during disposal, manual hand valve for water refill with interior threaded refill inlet with air gap as per manufacturer specification.

LIFTING STATION FOR OIL TRAP

Pressure sensor controlled single or twin wastewater pumps with multi-vane impeller to pump wastewater with or without sewage (open channel passage 40 mm). Pump shall be rated submersible (IP 68) with necessary cabling and sound-absorbing underlay mat (10 mm thick) or as per manufacturer specification.

Pump arrangement shall be vertical/ horizontal outlet with integrated non-return valve, with/without closure valve (provided loose), with hose section or flange.

GREASE INTERCEPTOR

Prefabricated Grease separator shall be of HDPE / Polyethylene conforming to EN 1825 / DIN 4040 /



100 suitable for underground/above ground installation with integrated sludge trap, sloped interior base improves cleaning and reduces disposal time, inlet flow calming system and outlet flow regulation device, inlet and outlet interchangeable, slanted twin access covers with quick release odor tight snap closures, inspection window with interior cleaning arm. The contractor shall refer drawings for selection.

Grease separator shall have mix & pump version manually controlled odor free disposal, cleaning and refilling system at touch of button, maintenance free pump for separator cleaning and disposal, includes closure valve for easy pump removal, pump floor mount included with installation hardware and anti-vibration matt, manual hand valve for transfer from cleaning to disposal mode, of adequate pumping capacity, with necessary cabling, top mounted water jet(s) for grease layer breakup and water spray nozzles for interior wall cleaning during disposal, manual hand valve for water refill with interior threaded refill inlet with air gap as per manufacturer specification.

17.0 AIR RELEASE VALVE

Scope

Supplying and erecting air release cock of 25mm made from GM with necessary G.I. coupling for fixing on pipeline.

Material

Air release valve: Gun metal
Coupling: G.I.

Method of Construction

Air release valve with necessary GI coupling shall be fixed on pipeline with required labour, tools etc.

Method of measurement

Executed quantity shall be measured on number basis.

18.0 BLANK FLANGE

Blank flanges shall use at non-used / spare puddle flange. Jointing shall be done with bolts, nuts, washers and rubber insertion 3 mm thick, testing the flange and joints etc.

MATERIAL

Blank flange fabricated out of 6 mm thick MS plates of suitable size shall be used.

FIXING

Blank flange shall be fixed in position with appropriate location during execution phase.

19.0 GARDEN HYDRANT AND GARDEN HOSE PIPE

Supply, installation, Testing and Commissioning of Garden Hydrant with gun metal Ball Valve, Hose reel, Flexible hose Connection Provision and all required accessories etc.

20 mtr. Length 20 mm garden hose pipe.

20.0 WOLTMAN TYPE BULK WATER METER- AMR BASED



Woltman Type Bulk Water Meter- AMR Based:

Design, Supply, Installation, Testing, Commissioning of Woltman type Bulk Water Meter, CI/ Brass/ Bronze body material, totalizer made of copper cam/ suitable anti corrosive metallic material, totaliser metallic shall have 5 mm thick glass cover suitable against antifraud attempts, Flange End process connection, IP 68 protection class. AMR Woltman Type Water Meter with removable mechanism, magnetic drive, dry dial, and be fitted with a low mass rotor which is parallel to the direction of water flow and exhibits dynamic thrust relief, water meters complete with T Type strainer, ISO 4064 : 2005 with valid CE mark mentioning notified body number along with MID / OIML / ISO certification from a recognized International laboratory.

AMR System:

AMR System shall be Walk By / Drive By mode. Wireless AMR trans-receivers shall be directly fitted on meter or inbuilt, IP 68 protection class, water meter & AMR Module shall be of same brand. Single Command based AMR Reading and Minimum 90 days historical data retrieve facility, alarm indication/ recording (for Reverse Flow, back flow, Peak Flow, Minimum Flow, Low Battery Alarm, Volume below threshold, Volume above threshold, Reverse Meter, Meter Stopped), Minimum 10 years of AMR module battery life considering one no. communication per day.

21.0 MOSQUITO PROOF GRATING

Providing and fixing 100 mm dia. mosquito proof stainless steel overflow grating for tanks

22.0 R.C.C. PIPES

SCOPE :

This specification covers the requirements for manufacture, supplying, lowering, laying, jointing, testing and commissioning of reinforced cement concrete (RCC) pipes used for the conveyance of sewage & storm water .

CODES & STANDARDS :

The manufacturing, testing, supplying, jointing and testing at work sites of RCC pipes shall comply with all currently applicable statutes, regulations, standards and codes. in particular, the following standards, unless otherwise specified herein, shall be referred.

MATERIALS

IS : 458 Specification for pre cast concrete pipes (with and without reinforcement)

IS : 3597 Method of tests for concrete pipes.

IS : 432 Specification for mild steel and medium (tensile steel bars and hand drawn steel) wires for concrete reinforcement.

IS : 5382 Specification for rubber sealing rings for gas mains, water mains & sewers

IS : 516 Method of test for strength of concrete.

CODE OF PRACTICE

IS : 456 Code of practice for plain and reinforced concrete

DESIGN

Signature of Bidder



Design of RCC pipes including reinforcement details and the ends of pipes shall be in accordance with the relevant clauses of IS : 458.

GENERAL

The method of manufacture of RCC pipes (Class NP 3) shall be such that the form and the dimensions of the finished pipes are accurate within the limits specified in relevant clause of IS : 458. The surfaces and edges of the pipes shall be well defined and true, and their ends shall be square with the longitudinal axis. The ends of the pipes shall be further reinforced by an extra ring of reinforcement to avoid breakage during transportation.

The RCC pipes and rubber rings shall be systematically checked for any manufacturing defects by experienced supervisors so as to maintain a high standard of quality.

The engineer shall at all reasonable times have free access to the place where the pipes and collars/rubber rings are manufactured for the purpose of examining and testing the pipes and collars/ rubber rings and of witnessing the test and manufacturing.

All tests specified either in this engineer's requirements or in the relevant Indian standards shall be performed by the supplier/contractor at his own cost and in presence of the engineer if he so desires. For this, sufficient notice before testing of the pipes and fittings shall be given to the engineer.

If the test is found unsatisfactory, the engineer may reject any or all pipes of that lot.

MATERIALS

CEMENT

Alphate resisting cement shall be used for the manufacture of RCC pipes and fittings and shall conform to IS 12330.

AGGREGATES

Aggregates used for the manufacture of RCC pipes shall conform to 3 of IS : 383. The maximum size of aggregate should not exceed one third the thickness of the pipe or 20mm, whichever is smaller for pipe size above 250 mm. For 80 to 250 mm size, the maximum size of the aggregate shall be 10 mm.

MIXING AND CURING WATER

Water shall be clean, colourless & free from objectionable quantities of organic matter, alkali, acid, salts, or other impurities that might reduce the strength, durability or other desirable qualities of concrete and mortar.

REINFORCEMENT

Reinforcement used for the manufacture of the reinforced concrete pipe shall conform to mild steel Grade I or medium tensile steel bars conforming to IS : 432 (part-1) or hard-drawn steel wire conforming to IS : 432 (part-2) or structural steel (standard quality) bars conforming to IS 2062. Reinforcement cages for pipes and collars shall be as per relevant requirement of IS : 458.

CONCRETE

Concrete used for the manufacture of RCC pipes shall conform to IS : 456. The minimum cement content and minimum compressive strength of concrete shall be as per relevant requirements of IS : 456. Compressive strength tests shall be conducted on 15 cm cubes in accordance with the relevant requirements of IS : 456 and IS : 516.



CURING

Pipes manufactured in compliance with IS : 456 shall be water cured in accordance with the relevant requirements of IS : 456.

DIMENSIONS & TOLERANCE

The internal diameter, wall thickness and length of barrel, reinforcement (longitudinal and spiral), type of ends and minimum clear cover to reinforcement and strength test requirements shall be as per the relevant clauses / tables of IS : 458 for class NP3 RCC pipes.

The tolerances regarding overall length, internal diameter of pipes or sockets and barrel wall thickness shall be as per relevant clause of IS : 458.

WORKMANSHIP & FINISH

Pipes shall be straight and free from cracks except that craze cracks may be permitted. the ends of the pipes shall be square with their longitudinal axis.

The outside and inside surfaces of the pipes shall be smooth, dense and hard, and shall not be coated with cement wash or other preparation unless otherwise agreed to between the engineer and the manufacturer or supplier.

The pipes shall be free from defects resulting from imperfect grading of the aggregate, mixing or moulding.

The pipes shall be free from local dents or bulges greater than 3 mm in depth and extending over a length in any direction greater than twice the thickness of barrel.

The deviation from straight in any pipe throughout its effective length, tested by means of rigid straight edge parallel to the longitudinal axis of the pipe shall not exceed, for all diameters 3 mm for every meter run.

TESTING

All pipes for testing purposes shall be selected at random from the stock of the manufacturer and shall be such as would not otherwise be rejected under the criteria of tolerances as mentioned in IS : 458.

During manufacture, compressive strength of concrete cubes shall be done as described in IS 516. For pressure pipes, splitting tensile strength tests of the concrete cylinders shall be carried out as described in IS 5816. The manufacturer shall supply, when required to do so by the engineer, the results of compressive tests of concrete cubes and split tensile tests of concrete cylinders made from the concrete used for the pipes. the manufacturer shall supply cylinders or cubes for test purposes required by the engineer and such cylinders or cubes shall withstand the tests prescribed as per IS : 458. Every pressure pipe shall be tested by the manufacturer for the hydrostatic test pressure, for non-pressure pipes, 2 percent of the pipes shall be tested for hydrostatic test pressure in accordance with IS 458.

The specimen of pipes for the following tests shall be selected in accordance with relevant clause of IS : 458 and tests in accordance with the methods described in IS : 3597.

Hydrostatic Test
Three-edge bearing Test
Permeability Test

SAMPLING & INSPECTION



In any consignment, all the pipes of same class and size and manufactured under similar conditions of production shall be grouped together to constitute a lot. The conformity of a lot to the requirements of this specification shall be ascertained on the basis of tests on pipes selected from it.

The number of pipes to be selected from the lot for testing shall be in accordance with table 22 of IS : 458.

Pipes shall be selected at random. In order to ensure randomness of selection, all the pipes in the lot may be arranged in a serial order and starting from any pipe, every pipe shall be selected till the requisite number is obtained and or procedures given in IS 4905 may be followed.

All pipes selected shall be inspected for dimensional requirements, finish and straightness. A pipe failing to satisfy one or more of these requirements shall be considered as defective.

The number of pipes to be tested for tests under clause 10.2 shall be in accordance with column 4 of table 22 of IS : 458. These pipes shall be selected from pipes that have satisfied the requirements of dimensions, finish and deviation from straight.

A lot shall be considered as conforming to the requirements of IS : 458 if the following conditions are satisfied.

The number of defective pipes (those not satisfying one or more of the requirements for dimensions, finish and deviation from straight shall not be more than the permissible number given in clause 8 & 9 of IS : 458.

All the pipes tested for various tests as per Clause shall satisfy corresponding requirements of the tests.

In case the number of pipes not satisfying requirements of any one or more tests, one or two further samples of the same size shall be selected and subjected to the test or tests in which the failure has occurred. All these pipes shall satisfy the corresponding requirements of the test. In the event they do not, the lot will be rejected.

MARKING

The following information shall be clearly marked on each pipe :

Internal diameter of pipe

Class of pipe

Date of manufacture and

Name of manufacturer or his registered trademark or both.

CARTING & HANDLING

Unless waived by the engineer, method statements shall be submitted by the contractor for the approval of the engineer before the handling, transportation and laying of any pipes commences. All pipes shall be handled and stored in compliance with the manufacturer's recommendations. Pipes and fittings /specials shall be transported from the factory to the central pipe store and unloaded there before being transported to site. At every point of loading or unloading, all pipes and fittings shall be lifted using approved lifting tackle. Unloading by rolling down any form of inclined ramp will not be permitted. Pliable straps or slings shall be used to lift pipes. Rope, wire rope, hooks or chains shall not be allowed to come into contact with any pipe surface. All pipes shall be thoroughly inspected on arrival on site and immediately prior to installation. Any damage to the pipes shall be notified to the engineer for a



decision as to the acceptability of the pipes, with or without repairs or remedial work. The final judgement will be taken by the engineer based on his judgement of the suitability of the items for the purpose intended.

STORAGE

Each stack of pipes shall contain only pipes of same class and size, with consignment or batch number marked on it with particulars of suppliers wherever possible. storage shall be done on firm level and clean ground and wedges shall be provided at the bottom layer to keep the stack stable. the stack shall be in pyramid shape or the pipes laid lengthways and crosswise in alternate layers. the pyramid stack shall be made for smaller diameter pipes for conserving space in storing them. the height of the stock shall not exceed 1.5 m.

Rubber rings shall be stored in a clean, cool store away from windows, boiler, electrical equipment and petrol, oils or other chemicals.

PIPELINE CONSTRUCTION (GENERAL)

Pipes shall be laid and jointed in accordance with all relevant recommendations of the manufacturer. Any variations between the manufacturer's recommendations and this specification shall be highlighted in the contractor's method statements and a ruling will be given with the approval. All pipelaying shall be performed by experienced and competent pipelayers.

The line of the pipe shall be set out and agreed with the engineer well in advance of the excavation. Surface stripping, excavation, pipelaying, backfilling and reinstatement shall follow each other without undue delay or interval between these activities.

LAYING OF PIPES

In laying the pipes and fittings/ specials the center for each manhole / chamber or pipeline shall be marked by a peg. Contractor shall dig holes for and set up two posts (about 100 x 100 x 1800 mm) at each manhole / chamber or junction of pipelines at nearly equal distance from the peg and at sufficient distances there from to be well clear of all intended excavation, so arranged that a sight rail when fixed at a certain level against the post shall cross the center line of the manhole/chamber or pipe lines. the sight rail shall not in any case be more than 30 m apart, intermediate rails shall be put up if directed by engineer.

Boning staves of 75 mm x 50 mm size shall be prepared by contractor in various lengths, each length being of a certain whole number of meters and with a fixed tee head and fixed intermediate cross pieces, each about 300 mm long. The top-edge of the cross piece must be fixed below the top-edge of the tee-head at a distance equal to the outside diameter of the pipe or the thickness of the concrete bed to be laid as the case may be. the top of cross pieces shall indicate different levels such as excavation for pipe line, top of concrete bed, top of the pipe etc. as the case may be.

The sight rail of size 250 mm x 40 mm shall be screwed with the top edge resting against the level marks. The centre line of the pipe shall be marked on the rail and this mark shall denote also the meeting point of the centre lines of any converging pipes. a line drawn from the top edge of one rail to the top edge of the next rail shall be vertically parallel with the bed of the pipe, and the depth of the bed of pipe at any intermediate point may be determined by letting down the selected boning staff until the tee head comes in the line of sight from rail to rail.

The post and rails shall be perfectly square and planed smooth on all sides and edges. the rails shall be painted white on both sides, and the tee-heads and cross-piece of the boning staves shall be painted black.



For the pipes converging to a manhole/chamber at various levels, there shall be a rail fixed for every different level. when a rail comes within 0.60 m of the surface of the ground, a higher sight-rail shall be fixed for use with the rail over the next point. the posts and rails shall in no case be removed until the trench is excavated, the pipes are laid and engineer gives permission to proceed with the backfilling.

LAYING OF PIPES & FITTINGS/SPECIALS

The joints and interiors of all pipes and fittings shall be carefully cleaned before installation. whenever pipelaying is interrupted for any reason, the open end of the pipeline shall be sealed with a suitable expanding stopper or a properly fitted temporary wooden stopper and exposed pipes shall be suitably protected from stones and other objects falling into the trench from above.

The permissible tolerance for pipelines in trenches shall be 6mm in level and 25mm in line between manholes. After the laying of a length of a pipeline but before testing the crown of the pipe shall be checked for level and alignment and any necessary adjustment made by unjointing and removing the pipes concerned, adjusting the bedding, relaying the pipes and rechecking for line and level.

For pipeline jointing systems incorporating flexible jointing rings, pipes shall be laid with the spigot end pointing in the direction of flow and with a gap between the end of the spigot and the base of the socket, or between spigots. rubber rings shall comply to IS : 5382.

JOINTING

Pipe section shall be joined utilising spigot and socket flexible joint with rubber ring, as per relevant IS after jointing, extraneous material, if any, shall be removed from the inside of the pipe and the newly made joints shall be thoroughly cured. the rubber sealing rings used for jointing, shall conform to IS : 5382.

The RCC pipe with the rubber ring accurately positioned on the spigot shall be pushed well home into the socket of the previously laid pipe by means of uniformly applied pressure with the aid of a jack or similar appliance. The RCC pipes shall be of spigot and socket type and rubber rings shall be used, and the manufacturer's instructions shall be deemed to form a part of these engineer's requirements. The rubber rings shall be lubricated before making the joint and the lubricant shall be soft soap water or an approved lubricant supplied by the manufacturer.

BEDDING

The type of bedding for the RCC pipes (granular, concrete cradle – PCC, RCC, concrete encasement, etc.)

GRANULAR BEDDING

Material used for bedding should be of granular material, free from sharp edges and sharp angles, well graded and durable under influence of ground water. The material selected shall consist of gravel (uncrushed or crushed), crushed rock or crushed concrete. uncrushed gravel is obtained from the natural disintegration of rock.

Well graded gravel of varying size from 5 mm to 14 mm shall be used. percentage distribution of each size for graded aggregate is mentioned in table 2.1 below:

Where pipes are laid with a granular bed or surround the appropriate bedding material shall, as soon as a section of trench has been trimmed to grade, be placed carefully over the full trench width without segregation. The material shall be spread and thoroughly compacted by approved mechanical means in successive uniform layers each not exceeding 150 mm compacted thickness to produce a uniform bed to the required gradient. where plate vibrators are used, there shall be a minimum of one pass for crushed



stone and two passes for sands. hand tamping will only be permitted where insufficient space is available to allow the use of mechanical plant, the minimum thickness of compacted granular material shall be as follows:-

150mm (minimum 100mm under sockets) for pipes not exceeding 300mm nominal diameter, except when trench is in rock.

200mm (minimum 100mm under sockets) for pipes greater than 300mm nominal diameter, or all pipes when trench is in rock.

The pipes shall then be set evenly on the bed, great care being taken to ensure uniform support for the entire length of the pipe.

Pockets in the bedding shall be formed at each pipe joint to permit jointing to be carried out without the sleeve or socket of the pipe joint bearing on the bedding material and without bedding material entering the joint.

After the pipeline alignment and joints have been inspected and approved by the engineer, the water testing of the pipeline satisfactorily completed, and, where appropriate, the annular gap at each pipe joint sealed, each joint pocket shall be carefully filled with granular material and thoroughly compacted up to the same level as the top of the bedding. granular bedding material of the same type shall be placed on both sides of the pipeline in successive uniform layers not exceeding 150mm thick and compacted according to one of the methods given in table 2.2 as agreed with or directed by the engineer. care shall be taken to ensure that no cavities remain under the pipe, and that the pipes are not displaced by differential pressure from either side.

When placing and compacting surround material the contractor shall take care not to displace or damage the pipes, the tipping of surround material from ground levels directly onto the pipes shall not be permitted.

Unless otherwise detailed on the drawings, for pipes with a full granular surround the granular material shall extend up to a minimum height of 300mm over the crown of the pipes, for rigid pipes unless otherwise detailed, the granular material shall extend up to the springing level of the pipe, the surround shall be completed by the careful placing of selected excavated material in layers not exceeding 150mm thick, thoroughly compacted on both sides of the pipeline to a level at least 300mm above the crown of the pipes.

For pipelines of 600mm diameter or greater the bed should be prepared ahead for approximately two pipe lengths whilst two pipes are being laid and the previous two pipes are receiving side filling, for pipelines less than 600 mm diameter the lengths of each stage shall be agreed with the engineer.

If the contractor wishes to use any other method of laying pipes in granular bedding or surround he must submit his proposals in writing to and obtain the approval in writing from the engineer well in advance of the date when he wishes to perform the work.

CONCRETE BEDDING

Concrete shall be grade M 20 unless otherwise detailed on the drawings / BOQ.

The minimum thickness of concrete between the bottom of the pipe and the trench shall be 0.25 x nominal pipe diameter, subject to 150mm minimum, with a minimum 100mm beneath sockets.

The pipes shall be set to correct alignment as detailed below :-



The contractor may use rectangular concrete blocks (two per pipe) made of grade M15 concrete, cast at least 7 days before use, together with pairs of approved hardwood wedges of the same width as the blocks in order to align and support the pipe before concreting, the blocks and wedges shall be of sufficient size and suitably founded on the bottom of the trench to support the pipe adequately without settlement or movement at any stage, the blocks and wedges should be placed near the end of each pipe length and should be left undisturbed during jointing of subsequent pipes and during construction, although the wedges should be removed during placing of the concrete.

Blocks may have thin tie wires cast in to assist in holding down the pipe when the concrete surround is being mechanically vibrated.

After approval of the joints and satisfactory testing of the pipeline a transverse flexible joint shall be formed by insertion of a template of compressible joint filler consisting of bitumen impregnated insulating board as per BS 1142 part 3 or other equally compressible material shaped exactly to the pipe and full extent of the concrete cradle or surround, unless otherwise specified, the thickness of this flexible joint shall be a minimum of 25mm.

For spigot and socket pipes, the flexible joint in the concrete shall be aligned with the face of the socket. For sleeve type and flexible mechanical joints, the flexible joint shall be aligned with one end of the sleeve or mechanical joint. In certain cases, a flexible joint may be required at both ends of the sleeve or mechanical joint. The concrete infill for flexible mechanical joints shall only be placed after the application of the specified protection materials to the joint, no steel reinforcement shall pass through the flexible joint.

Concrete for beddings, surrounds and joint infills shall be placed carefully and uniformly, suitable measures being adopted to ensure that the pipeline is not displaced by differential side pressure or by flotation. Concrete shall be properly compacted with particular care being taken to ensure that no cavities are left underneath the pipe.

The concrete shall provide a minimum cover to the pipe of 150mm for surrounds.

Concrete beds to pipes of all diameters and surrounds to pipes of one metre diameter or less shall be poured in a single operation. concrete surrounds to pipes over one metre diameter shall normally be poured in two lifts, with a horizontal joint not more than 100mm below the crown of the pipe. concrete shall be prevented from entering pipe joints.

Formwork shall be used for all vertical faces. Side forms should not normally be required, if trench widths specified are such that the concrete bedding / surround will extend the full width of the trench.

All formwork used for forming the concrete bedding shall be removed, unless the written approval of the engineer is given to leave it in place for safety or similar reasons. Where side forms have been required, backfilling shall be proper to fill the voids left on removal of the formwork.

The bedding and surround shall be completed by the careful placing of selected excavated material in layers not exceeding 150mm thick, thoroughly compacted by hand on both sides of the pipeline to a level at least 300mm above the crown of the pipes, as this material is placed and compacted in the trench, the supports to the sides of the trench shall be concurrently partly withdrawn so that there are no voids or uncompacted zones.

Except where otherwise specified or instructed by the engineer, no traffic load may be imposed upon the trench within 72 hours of the placing of the concrete cradle or surround.

If the contractor wishes to use any other method of laying pipes in concrete cradle or surround, he must submit his proposals in writing to and obtain the approval in writing from the engineer well in advance of the date when he wishes to perform the work.



SPECIAL FOUNDATION IN POOR SOIL

Where the formation of the trench is found to consist of material which is unstable to such a degree that in the opinion of the engineer, it cannot be removed and replaced with an approved material thoroughly compacted in place to support the pipe properly, a suitable foundation for the pipes, consisting of piling, timbers or other materials shall be prepared by the contractor and as instructed by engineer.

INSPECTION OF PIPELINES

As soon as the pipeline has been completed from manhole to manhole the contractor shall run through the pipes both backwards and forwards a double disc or solid or closed cylinder 75 mm less in diameter than the internal diameter of pipes.

If as a result of the removal of any obstructions the engineer considers that damages may have been caused to the pipe lines, he shall be entitled to order the stretch to be tested immediately. should such test prove unsatisfactory, contractor shall make good the pipeline and carry out such further tests as are ordered by the engineer.

SITE TESTING

After laying & jointing of RCC pipes is completed the pipe line shall be tested. All equipment for testing shall be supplied by the contractor. damage during testing shall be contractor's responsibility and shall be rectified by him to the full satisfaction of the engineer. water for testing of pipeline shall be arranged by the contractor at his own cost.

After the joints have been checked by the engineer and before backfilling of the trenches, the entire section of the sewer shall be proved by the contractor to be watertight by filling the pipes with water to the level of 1.50m above the top of the highest pipe in the stretch and heading the water up for a period of one hour. the apparatus used for the purpose of testing shall be approved by engineer. the contractor if required by the engineer shall de-water the excavated pit and keep it dry during the period of testing. The loss of water over a period of 30 minutes shall be measured by adding water from a measuring vessel at regular 10 minutes intervals and noting the quantity required to maintain the original water level. for acceptance of the section of pipeline under test the average quantity added shall not exceed 1 litre/ hour/100 linear metres / 10mm of nominal internal diameter. any leakage including excessive sweating which causes a drop in the test water level in excess of the permitted amount will result in the pipeline being rejected. the contractor will be required to remove and re-lay the pipeline for re-testing.

Water used for the test shall be removed from pipes and not discharged to the excavated trenches.

23.0 HYDROPNEUMATICS SYSTEM:

Scope:

The specification covers design, performance, manufacture, construction features, inspection, testing, delivery, installation, commissioning of Hydro pneumatic pressurized system consisting of balancing tank with mounting pads, pump-motor set with coupling and coupling guard, common base plate, bell mouth, piping, isolation valves, NRVs, fittings, control panel, pressure switches, Foundation SS Nut, SS washers, SS bolt, antivibration pad, suction header Pipe and Valve from UG tank to Pump , Strainer, Suction , discharge and All flanged end, pumps & allied piping and accessories, expansion bellow, Completing the pipe alignment at the joint of discharge header to supply pipe with bolts nuts & rubber packing, chain pulley block with endless chain , Electrical Panel, Cable, cable tray up to pump panel and other accessories required for complete installation of hydro pneumatic system at site.

Compact self-contained Hydro-booster system factory fabricated and fitted, fully integrated comprising of following :

In-line, vertical multistage, centrifugal clear water pumps with SS-304 casing, S.S 304 impeller



and SS-304 shaft. C.I. Base CED (Cathode Electrode Deposition) coating & head TEFC motor (with mechanical seal), dry run protection, antivibration paid, 2 pole Motor & IE3 Efficiency.

Panel mounted microprocessor based multi pump controller with large graphical display with VGA 240 x 320 pixels and variable frequency drive (VFD) integrated in a single body, pressure sensor transmitter, IP 55 enclosure, diodes to indicate pump ready, earthing, pump running and fault condition, Cascade Operation. Each incomer and Outgoing feeder should be capable for protection against Overload, Short Circuit and Phase reversal condition and shall be capable to communicate with other controllers following. The PLC shall support MODBUS-IP communication for its compatibility to integrate with 3rd party BAS system. Controller shall authorize Read/Write command via BMS. System should be capable to compensate for frictional losses at lower flows. All alarms should be displayed in the controller. System should be equipped with dry running protection. Indication of all type of faults / on-off status / electrical parameters shall be available on panel and central IBMS monitors. On-off operation for all pumps shall be available on BMS system.

Electronic type low water level controller with LED panel to operate pump (necessary contacts along with minimum one PLC operated spare contacts required), with probe & all control wiring from Panel to tank to operate the system automatic/manual & shall prevent the pump from dry running.

Scope shall also include power and control cable of required size, termination, cable tray from Pump to Control panel, control cable as wherever required etc. complete the job.

Pre-charged diaphragm pressure vessel PN 10 with interchangeable membrane, charging connection, connected to outlet header with necessary pipe, flanges, gaskets, isolating valves, nuts/bolts etc. complete.

Set of accessories such as GI C Class headers of suction and discharge for (working and Assist by pump assembly) with CED Coating, cast iron control valves, Cast Iron non return valves, pressure transducers, pressure gauge with Isolation Valve of PN 10 etc. complete the job. Require complete company fitted ready-to-connect packaged system. Pumping system shall be as per GRIHA Norms.

The items/quantities shall be measured and paid upon completion of the linked milestone as per schedule 10 for the respective item.

Construction features:

The major components of the system shall be as follows:

A. PRESSURE VESSEL:

FRP tank (Pressure vessel) for min. 10 Kg/cm² Pressure rating with inbuilt aircell to be provided if specified in BOQ.

FRP Tank shall be tested at Factory as well as site before installation.

The tank shall be provided with all accessories viz. mounting arrangement, isolation valve, pressure gauge, etc.

B. PUMP:

Inline vertical multistage pump shall be provided. Variable frequency drive shall be provided with one of the installed pump – if specified in Schedule of quantity.



The pump – motor set and shall be suitable for 3 Ph., 415 V, 50 Hz. AC power supply and having 2900 RPM speed. The pump shall be installed with isolation butterfly valve, non return valve, etc. The detailed specification for pump & motor is as below:

Vertical inline Pump

C. Codes & Standards :

The design and manufacture of the pump shall comply with all currently applicable statutes, regulations and safety codes in the locality where the equipment will be installed.

D. Design Features:

The pump shall be capable of developing required total head at rated capacity. Impeller shall be closed type and shall be dynamically balanced. The pump shall have non overloading characteristics.

E. Constructional Features:

The casing shall be of rigid construction and shall have side suction and side delivery in case of inline pump and side suction and central delivery in case of submersible centrifugal pump.

The pump shall have very small length suction and delivery pipe connections which will result in minimum friction loss.

Impeller shall be of one piece and shall be of SS CF8 M.

The shaft shall be of S.S. and its surface shall be properly finished.

Shaft sleeves shall be provided to protect shaft from any damage.

Bearing shall be ball or roller type.

Mechanical seal shall be provided to avoid any leakage.

F. Inspection & Testing:

The pump shall be offered for visual inspection before dispatch.

Material test certificates for the various pump components shall be furnished for purchaser's approval.

Hydrostatic test shall be carried out at 1.5 times the maximum discharge pressure:

All the tests shall be witnessed by purchaser.

G. Drawings:

Following drawings shall be furnished by the Contractor:

Overall dimensional drawing.

Cross-sectional drawings with all dimension (vertical and horizontal) with Bill of Material and Material of Construction.



H. Accessories:

The pump shall be provided with all accessories such as base plate, foundation bolts, strainer, pressure gauge, etc. All accessories required for proper and safe operation shall be furnished with the pumps.

I. Pressure transducer:

The system shall be installed with the pressure transducer which shall be set at predetermined pressure to automatically control the pump operation.

J. Drawings:

Following drawings shall be furnished by the CONTRACTOR:

- 1 Overall dimensional drawing.
- 2 Cross-sectional drawings with Bill of Material and Material of Construction

K. Manifolds, Valves, Base frame & Accessories

- o Suction and Delivery manifolds in Hot Dip Galvanized steel. (80-110micron)
- o DIN standard flange connections.
- o One non-return valve and isolating valves for each pump is provided in delivery side and one isolating valve is provided in suction side.
- o Manifolds and valves are suitable for 16bar pressure rating.
- o Pumps should be mounted on the common base frame.
- o Base frame and panel side support is in Galvanized steel.
- o Suitable range of pressure gauges and pressure transmitter should be connected at the discharge manifolds.
- o Vibration dampening pad for minimize the noise and vibration in the system.
- o Concrete foundation as per manufacturer recommendation. (1.5 times X the weight of the Pumping system).

TECHNICAL DATA SHEET FOR HYDROPNEUMATICS pumping system:

Particular	Data to be filled by Contractor
Pump	
Make	
Type & Model; Vertical Multistage	
Discharge in cum/hr	
Head (Meters of WC)	
Number of Pumps	
Total system flow (cum/hr)	
Shut off Head (Meters of WC)	
Efficiency (%)	
No. of Stages	
Suction End I.D.	
Delivery End I.D.	
Details of N.P.S.H.	
Vibration Isolation Detail	
Skid Details	
Operating Weight	
Overall Dimension (MM)	



Particular	Data to be filled by Contractor
Mechanical Seal Detail	
Material	
Pump Head - Cast Iron	
Pump Base- Cast Iron	
Impeller-SS 304	
Chamber-SS 304	
Shaft-SS316	
Motor stool-Cast Iron	
Shaft seal Cartridge type(SiC/Carbon)	
Rubber parts-EPDM	
Motor	
Make	
Model	
Power Requirement (HP / KW)	
R.P.M.	
No. of pole: 2 pole	
Efficiency class-IE3	
Insulation class-F	
Enclosure class-IP 55	
Supply Frequency-50Hz	
Supply voltage-3X380-415V	
Built in Thermistor-PTC	
Control Panel	
Enclosure class-IP 55	
DETAILS OF PLC	
DETAILS OF VFD	
Pressure Vessel	
Make	
Model Number	
Material of construction (Vessel/Bladder)	
Dimension	
Overall capacity	
Cut-in/Cut-out setting	
Capacity at specified cut-in/cut-out	
Overall dimension of skid mounted system	
Weight (Static/Dynamic)	
ACCESSORIES & SERVICES REQUIRED	
Base Plate	
Foundation bolts	
Companion flanges	
Spare parts required	
Maintenance tools required	
Cut in pressure	
Cut off pressure	
Plant room suction matching flange & outside plant room flange	
Suction & delivery piping: MS, hot dipped galvanized, Class 'C' with CED Coated	
Suction, delivery valves & header valves: Required, flanged Cast Iron valves with SS internal parts. Make: Kirloskar / KSB / AUDCO/ FLOVEL	



Particular	Data to be filled by Contractor
Flanged Ball / Butterfly valve on suction and delivery of each pump & Flanged Non slam, spring operated dual plate type check valve on delivery side of each pump & on header	
Control Panel: With Starter. One pump of similar rating shall have VFD Required with all protections & sequential timer for main pumps. Also required Finolex / CCI / Gloster make cable from motor to panel	
Level Transmitter: Required for 0-5 mtr. Range and shall be panel mounted and interlocking with pump	
Pressure Transmitter	
Pressure Gauge: Required at delivery header.	
Gaskets: 'Champion' make	
Hardware: Zinc coated	

24.0 DRINKING WATER TREATMENT PLANTS

Reverse-osmosis Automatic, water treatment plant comprising of RO plant etc. according to input water quality/ analysis. The scope shall include interconnection piping, valves, instruments, back wash arrangement, including Raw water inlet pumps a-1 working + 1stand by pump set, micron filter, High pressure pump (1W+1S), and all other required pump set is auto operation, including dry run protection, RO Module, all valve controls, SS 316 interconnecting piping of suction and discharge header, control panel and other necessary cabling works, 2 pole Motor & IE3 Efficiency etc. complete the job. Panel mounted PLC based pump controller, IP 55 enclosure, ON-OFF and Trip Indicating lamps in each incomer and outgoing feeders, The PLC shall support MODBUS-IP communication for its compatibility to integrate with 3rd party BAS system. PLC shall authorize Read/ Write command via BMS. earthing, interlocking arrangement, dry run protection, cascade operation, working / standby selection, with provision of remote on/off operation complete as required. The on/off operations for all pumps shall be available on central BMS system. Each incomer and Outgoing feeder should be capable for protection against Overload, Short Circuit and Phase reversal condition and shall be capable to communicate with BMS. Scope shall also include supply, laying, termination of control and power cables of adequate size, and arrangement of cable tray from Pump to Control panel etc. to complete the job. SITC of electronic type low water level controller with LED panel to operate pump (necessary contacts along with minimum one spare contact required), with probe & all control wiring to operate the system automatic/manual & shall prevent the pump from dry running.

Mounting Height : 500mm from the bottom of tank. SITC of electronic type low & high water level controller with LED panel to operate pump (necessary contacts along with minimum one spare contacts required), level controller with operational mode as one pump working at low level, both pumps at high level with a hooter alarm and cut off at dry level with probe & all control wiring to operate the system automatic/manual & shall prevent the pump from dry running.

Mounting Height (Low Level) : 500mm from the bottom of tank

Mounting Height (High Level) : free board level of tank. All Automatic valve to be Electronic operated.

All Pumping systems shall be as per GRHA Norms.

25.0 SS STORAGE TANK:

SS 316 Drinking Water storage tank , Working Pressure - 6 Bar, test pressure shall be 1.5 time with flanged connection as required, capable of storing Cold water insulated with 50 mm thick PUF Insulation with 26 swg aluminium cladding. Shell shall be fabricated with 3 mm thick plate and dished ends with 3 mm thick plates complete with manhole cover, safety valve drain, nozzle, inlet and outlet nozzles industrial type temperature



indicator. The storage tank shall be provided with Manhole Cover. item including of necessary supporting stand etc. complete the job.

26.0 WATER COOLER WITH RO

Providing and fixing S.S. water cooler of 80ltr storage capacity with 60ltr per hr. cooling capacity. Including inbuilt R.O.Plant consisting of considering the inbuilt booster pump, dry run protection, water purification filters, piping, isolation valves, instruments supports, etc. complete & Medium Penetration UV. Including all Inter connection piping and valve all comp. System as per drinking water IS standard requirement. it is recommended to provide blending system of water at attain TDS level between 250-300 ppm. The supplier has to also supply and installation of SS-316 storage tank - 80 ltr. capacity.

Material:

The water cooler shall be suitable for operation on 230 V +/- 10% , 50 Hz, single phase AC supply with hermetically sealed type suction cooled compressor with overload protection conforming to IS :- 10617(part I) : 1983 with amendment no 1&2.

Tank:

Tank shall be fabricated from SS 316 as per ISI 304 and shall be made by electrically seam welded lap joints with PUF insulation, with required number of Taps. Use of lead soldering material for sealing the joints of water tank is not permitted. Water tank cover and lid bottom shall be made of 1.25 mm aluminium sheet duly anodized / epoxy painted / high impact polystyrene (HIP) of 1.5 mm thickness. Positive locking of the lead is to be provided (lock with two keys). A drain valve at the bottom of the storage tank to be provided to draw out water while cleaning.

Cabinet (Body):

The cabinet of the water cooler shall be made of SS 316 . The front panel, below the water outlets in the storage type water coolers shall be made of stainless steel. The drain pan for storage type water coolers shall be made of stainless steel. The bottom pedestal shall be made of stainless steel. Pedestal shall have a minimum ground clearance of 100 mm for ease of cleaning. Pedestal shall be strong enough to withstand weight with storage tank full and shall be reinforced to prevent skewing. The body shall be held securely with the pedestal with stainless steel nuts and bolts. The drain size should be 25 mm or above. In case water outlets are provided on three sides then all the three lower panels should be made of aluminium sheet or stainless steel sheet.

The mild steel components used in the manufacture of the cabinet shall be individually degreased, pickled, scrubbed and rinsed to remove grease, rust, scale or any other foreign elements. Immediately after pickling the MS parts shall be given phosphate treatment. The components along with the front panels shall then be given a primer coat with a finish coat of stove with a finish coat of stove enamel paint. The finish shall be smooth and uniform with hard tough film of the enamel adhering to the surface. The finish shall be free from all the visible defects and shall not chip when tapped lightly with a dull pointed instrument. Alternatively method of corrosion protection like plastic powder coating, electrostatic painting shall be permitted

Refrigeration coils to be fully soldered to the outside of the tank for good thermal contact and not merely tack welded.

There shall not be any gap between water tank cover (mask) and water tank to prevent rodent/ insect/ dust entry.

Water tank overflow should be adequately covered with strainer such as wire mesh etc to avoid



rodent/ insect/ dust entry.

Condenser Fan Motor:

The condenser fan motor shall be capacitor start and capacitor run (CSR) or permanently split capacitor (PSC) or alternatively permanently lubricated motor may be provided.

Thermostat:

The thermostat shall conform to IS: 11338-1985. The position of the thermostat shall be adjustable through a rotary switch mounted on the front or side panels. Min and max of the thermostat setting shall be from 0 degree Celsius and 25 degree Celsius which shall be marked.

Method of Construction:

The water cooler shall be fixed at designated place or as directed by the DTA, duly connected with inlet and drain by leak proof joints. The water cooler is to be erected on stand and tested.

Mode of Measurement: Executed quantity shall be counted on number basis. (i.e. each)

UV Drinking Water

Model Name	Data to be filled by Contractor
Flow Rate & QTY	
UV Dose	
UV Transmission	
Voltage	
Maximum Power Consumption	
Number of Lamps	
Rating	
MOC	
Max. Lamp Cable Length	
MOC	
End Connections (ASA ISO RF Flanges)	
Max. Operating Pressure	
Max. Operating Temperature	
Max. Sanitization Temperature	
Quartz Jacket MOC	
Lamp Replacement Reminder	
Lamp Failure Indication (with Alarm)	
UV Intensity Meter w/ 4-20mA Output	
Automatic Wiper System	
Sanitary TC End Connections	
UV Intensity Meter with IntelliDose	
Nitrogen Purged UV Intensity Sensor (with Isolated Design)	
4-20mA Output Signal	
RS485 / MODBUS Interface	
Built In Data Logging (3,000 records)	
Remote Lamp / On Off (hardwire or MODBUS)	
Control Panel Temperature Control (with automatic over temperature shutoff)	
Reactor Temperature Control (with automatic over temperature shutoff)	



Model Name	Data to be filled by Contractor
Automatic Wiping on Low UV	
Lamp Replacement Reminder	
Control Panel Safety Interlock Switch	

27.0 BOREWELL DOMESTIC WATER TREATMENT PLANT

Sea-water reverse-osmosis (SWRO) Automatic, domestic water treatment plant comprising of multigrade sand filter, Activated Carbon filter, RO plant etc. according to input water quality/ analysis. The scope shall include interconnection piping, valves, instruments, back wash arrangement, Including Raw water inlet pumps a 1 working + 1 stand by pump set, micron filter, High pressure pump(1W+1S), and all other required pump approved make) the pump set is auto operation, including dry run protection, RO Module, all valve controls, SS 316 interconnecting piping of suction and discharge header, control panel and other necessary cabling works, 2 pole Motor & IE3 Efficiency etc. complete the job. Panel mounted PLC based pump controller, IP 55 enclosure, ON-OFF and Trip Indicating lamps in each incomer and outgoing feeders, The PLC shall support MODBUS-IP communication for its compatibility to integrate with 3rd party BAS system. PLC shall authorize Read/Write command via BMS. Earthing, interlocking arrangement, dry run protection, cascade operation, working / standby selection, with provision of remote on/off operation complete as required. The on/off operations for all pumps shall be available on central BMS system. Each incomer and Outgoing feeder should be capable for protection against Overload, Short Circuit and Phase reversal condition and shall be capable to communicate with BMS. Scope shall also include supply, laying, termination of control and power cables of adequate size, end arrangement of cable tray from Pump to Control panel etc. to complete the job. SITC of electronic type low water level controller with LED panel to operate pump (necessary contacts along with minimum one spare contact required), with probe & all control wiring to operate the system automatic/manual & shall prevent the pump from dry running.

Mounting Height : 500mm from the bottom of tank (RAW UG Tank) SITC of electronic type low & high water level controller with LED panel to operate pump (necessary contacts along with minimum one spare contacts required), level controller with operational mode as one pump working at low level, both pumps at high level with a hooter alarm and cut off at dry level with probe & all control wiring to operate the system automatic/manual & shall prevent the pump from dry running.

Mounting Height (Low Level) : 500mm from the bottom of tank (Treated water UG tank)

Mounting Height (High Level) : 3000 mm from the bottom of tank (Treated water UG tank).

All Automatic valve to be Electronic operated. Raw Water Parameters (ppm)/ Borewell Water Parameters: Scope shall also include for borewell all water test parameters for the design of SWRO Plant consider 1.5 times TDS as compared to test report.

Consider TDS: 5000 minimum for designing of RO Plant. Below Treatment scheme is indicative only. If any other treatment is required, to be done by the contractor. all interconnection piping SS 316 only. Treated Water Parameters (PPM) pH : 6.0 - 7.0, Total Dissolved Solids : 100, Total Suspended Solids : Nil, Total Hardness as CaCO3 : 10

Technical Details WTP FEED PUMPS Capacity per pump - as per vendor, Head -35 mt Approx. Location -Pump Room Moc: SS body with CI Casing 1 Set = 2 Nos. Pump (1 Working + 1 Standby - cascade operation) Suction head -flooded positive suction. Chlorination Dosing System Pump Capacity : 0-6 LPH at 3.5 kg/cm2 MOC : PP Quantity : 01 No. Tank Capacity : 100 Ltrs. Tank MOC : HDPE Quantity : 01 No.

MULTI- GRADE PRESSURE SAND FILTER: Quantity : 1 no., M.O.C. : FRP, Flow Rate : as per vendor cum/hr, Filtration Rate: 15 cum/sqm/hr, Type of Unit: Down Flow, Filter Media : Silica, Pebbles, Gravels And Quartz Sand, Size : As per Vendor, Type of Unit : Vertical Cylindrical, Working Pressure Kg/cm2 : 2.5, interconnection Frontal Piping: SS316, Accessories & Instruments : 1. Pressure gage : at inlet & outlet

ACTIVATED CARBON FILTER: Quantity : 1 no., M.O.C. : FRP, Flow Rate : as per vendor cum/hr, Filtration Rate: 15 cum/sqm/hr, Type of Unit: Down Flow, Filter Media : Activate Carbon, Size : As per Vendor, Type of Unit : Vertical Cylindrical, Working Pressure Kg/cm2 : 2.5, interconnection Frontal Piping: SS316, Accessories & Instruments : 1. Pressure gage : at inlet & outlet.



Antiscalant Dosing System for RO: Pump Capacity : 0-6 LPH at 3.5 kg/cm², MOC : PP, Quantity : 01 No., Tank Capacity : 100 Ltrs., Tank MOC : HDPE, Quantity : 01 No.

SMBS Dosing System for RO: Pump Capacity : 0-6 LPH at 3.5 kg/cm², MOC : PP, Quantity : 0 No., Tank Capacity : 100 Ltrs., Tank MOC : HDPE, Quantity : 01 No.

Acid Dosing System for RO Pump Capacity : 0-6 LPH at 3.5 kg/cm², MOC : PP, Quantity : 01 No., Tank Capacity : 100 Ltrs., Tank MOC : HDPE, Quantity : 01 No.

Micron Cartridge Filter with Auto Dump Valve for RO:- Capacity : as per vendor m³/hr, Housing MOC : SS316, No. Cartridge : 1 Lot MOC PP, Size : 65 Micron, Size Suitable, Quantity : 01 No.

High Pressure Pump With VFD for RO:- Capacity per pump - as per vendor, Head: as per vendor, 1 Set = 2 Nos. Pump (1 Working + 1 Standby - cascade operation), Intermediate High Pressure Pump With VFD for RO: Capacity & head: as per Vendor 1 Set = 2 Nos. Pump (1 Working + 1 Standby - cascade operation), RO System WITH SKID AND ELECTRICAL PLC PANEL AND INSTRUMENT - No of Unit : 1 No., Feed Flow rate : as per vendor, Permeate Flow rate : as per vendor, Recovery : 80%, Membrane Type: Sea-water reverse-osmosis (SWRO) RO CIP System:- RO CIP Pump : As per vendor, MOC : SS316, RPM : 2900 RPM, No. of RO CIP Pump : 1 No., MCF : 5 Micron, MOC - PP, No of MCF Unit : 1 No., CIP Tank : 500 Liter HDPE, PH Correction Dosing System:- Pump Capacity : 0-6 LPH at 3.5 kg/cm², MOC : PP, Quantity : 01 No., Tank Capacity : 100 Ltrs., Tank MOC : LLDPE, Quantity : 01 No. Piping:- High Pressure Piping - SS316, Low Pressure Piping - SS 316, Flow Meter: 1 nos. WTP Feed Pump Discharge header, 1 nos. RO Permeate water, 1 nos. RO Reject water.

28.0 DEWATERING PUMP FOR SUMP DRAIN:

SCOPE

The scope includes Supply, installation, testing & commissioning of Submersible Non-Clog, single stage, single entry pumps connected to TEFC submersible motor for 415 + 10% volts, 3 phase, 50 cycles A.C. power supply with mechanical seal, pump connector unit with rubber diaphragm and bend, vertical discharge pipe. The pump shall be provided with a lifting device of pull chain/guide rail. (Pumps suitable to handle solids up to 20 mm size with C.I body, SS304 shaft, C.I/SS impeller).

Panel mounted microprocessor-based pump controller, IP 55 enclosure, ON-OFF and Trip Indicating lamps in each incomer and outgoing feeders, The PLC shall support MODBUS-IP communication for its compatibility to integrate with 3rd party BAS system. PLC shall authorize Read/Write command via BMS., interlocking arrangement, dry run protection, cascade operation, working / standby selection, with provision of remote on/off operation complete as require. The on/off operations for all pumps shall be available on central BMS system. Each incomer and Outgoing feeder should be capable for protection against Overload, earthing, Short Circuit and Phase reversal condition and shall be capable to communicate with BMS. Scope shall also include supply, laying, termination of control and power cables of adequate size, and arrangement of cable tray from Pump to Control panel etc. to complete the job.

SITC of electronic type High, Medium & Low water level controller with LED panel to operate pump (necessary contacts along with minimum one PLC spare contacts required), level controller with operational mode as one pump working at Medium level, both pumps at high level and cut off at dry level with probe & all control wiring to operate the system automatic/manual & shall prevent the pump from dry running.

Set of accessories such as CPVC SCH 80 discharge headers for (working and stand by pump assembly) from sump bottom to Basement ceiling, Cast Iron control valves, Cast Iron non-return valves, pressure gauge of PN 10 etc. complete the job. Pumping system shall be as per GRISA Norms.



DESIGN REQUIREMENT:

The total head capacity curve shall be continuously rising towards the shutoff with the highest at shut off.

The pump shall run smooth without undue noise and vibration.

The power rating of the pump motor shall not be less than the power required from zero discharge to zero head.

Pump shall be submersible, single stage and non-clog type.

It shall be suitable for handling turbid water containing stringy materials. The pump shall be designed to handle solids up to 50 mm dia size.

Delivery pipe shall be CPVC SCH 80. The required length of pipes and fittings up to discharge point shall be provided with necessary fittings.

Level switch (mercury/magnetic reed) to stop the pump automatically shall be supplied with the pump. Pump shall have three phase connections.

TECHNICAL DATA SHEET FOR DEWATERING PUMPS

Particular	Data to be filled by Contractor
Pump	
Make	
Type & Model: Non-Clog Submersible pump semi open impeller	
Discharge in cum/hr.	
Head (Meters of WC)	
Number of Pumps	
Total system flow (cum/hr.)	
Shut off Head (Meters of WC)	
Efficiency (%)	
No. of Stages	
Suction End I.D.	
Delivery End I.D.	
Details of N.P.S.H.	
Vibration Isolation Detail	
Skid Details	
Operating Weight	
Overall Dimension (MM)	
Mechanical Seal Detail	
Material	
Pump Housing: Cast iron, DIN W.-Nr. GG20	
Impeller: Ductile Cast iron, DIN W.-Nr. GCD450	
Impellers Type: Semi Open Impeller	
Motor housing: Cast iron, DIN W.-Nr. GG20	
All O rings: NBR Rubber	
Rotor shaft: stainless steel	
Type Bearing: Double-row angular contact ball bearing.	
Mechanical Seal: Double mechanical is SiC/SiC.	
Free Bull Passage: - 20mm	



Particular	Data to be filled by Contractor
Motor	
Make	
Model	
Power Requirement (HP / KW)	
R.P.M.	
No. of pole: 2 poles	
Efficiency class-IE3	
Insulation class-F	
Type of Motor :3 Phase Induction Motor.	
Supply Frequency-50Hz	
Supply voltage-3X380-415V	
Protection sensor- Thermal and moisture sensor	
Control Panel	
Enclosure class-IP 55	
DETAILS OF PLC	
ACCESSORIES & SERVICES REQUIRED	
Companion flanges	
Spare parts required	
Maintenance tools required	
Plant room outside plant room flange	
Suction, delivery valves & header valves: Required, flanged Cast Iron valves with SS internal parts Make : Kirloskar / KSB / AUDCO/ FLOVEL Flanged Ball / Butterfly valve on suction and delivery of each pump & Flanged Non slam, spring operated dual plate type check valve on delivery side of each pump & on header.	
Control Panel: PLC With Starter. Also required Finolux / CCI / Gloster make cable from motor to panel	
Level Transmitter: Required for 0-5 mtr. Range and shall be panel mounted and interlocking with pump	
Pressure Gauge: Required at delivery header.	
Gaskets: 'Champion ' make	
Hardware: Zinc coated	

Note:

- 1) M – Denotes material test certificate required.
- 2) Other specifications not mentioned in datasheet, shall be considered as per tender specification.

29.0 AIR TO WATER HEAT PUMP

Air to Water Heat Pump along with heating element of required capacity capable of operation on air to water basis, patented AES energy saving system, time setting, thermostat setting along with storage tank. The Heat Pump System should be based on a open circuit hot water design temperature of 60 °C out of the unit with 20°C input water temperature for operation.

Heat Pump Capacity: As per BOQ

Refrigerant - R407C/ 410/ 134a. Out Put Heating Capacity, COP: 3.6 to 3.8 and power connected load as per manufacture standard.

The unit shall have its own insulated storage capacity of 1000 ltr With PN 10 rating. The unit



shall have all electrical and Hydraulic safety devices inbuilt.

Hot Water Inlet/Out let Temp : 20 Deg C / 60 Deg C . item including of Electrical Panel, piping work and 50mm Rock wood insulation with 26G Aluminum Cladding in all piping. These units shall be completely factory assembled including thematic scroll compressor, air cooled condenser. Heat pump is equipped with microprocessor-based control, safety device, digital display unit, electrical panel, inbuilt pumping system & Self-cleaning system, Pump Shall have Working + Stand by with Automatic Cascade Operation. The controller shall support MODBUS-IP communication for its compatability to intergrate with 3rd party BAS system. Controller shall authorise Read/Write command via BMS. System should be capable to compensate for frictional losses at lower flows. All alarms should be displayed in the controller. System should be equipped with dry running protection. Indication of all type of faults / on-off status / electrical parameters shall be available on panel and central IBMS monitors. On-off operation for all pumps shall be available on BMS system.

All Pumping system shall be as per GRIHA Norms

Hot water pressurize storage tank

Scope:

Supplying, erecting and testing of horizontal/ vertical, pressurize Mild steel heavy duty storage tank of 10Bar working pressure, all internal surfaces exposed to water are glass-lined. Perma Glass Ultra coat second-generation glass coating technology prevents corrosion. With replaceable magnesium anode, temperature and pressure valve, with stainless steel spring set 95 degree Celsius, analogue temperature, Copper coil provides prolonged life and maximum heat transfer efficiency. The smart control Electric Expansion Valve (EEV) accurately controls the refrigerant volume to ensure the unit performs to maximum efficiency

Insulation: Entire tank is surrounded with high density fiber glass insulation to reduce costly heat loss: non- sagging and vermin- proof. To meet ASHRAE 90.1b-1992 standard depth of insulation cavity requires use fo remote bulb- type tank temperature control and thermometer.

Cabinet: heavy gauge steel with high quality powder coat paint provides additional insulating quantities for greater energy savings.

LININGS AND COATINGS

Each lining and coating has particular capabilities and limitations. Please consult the factory for recommendations on the uses of linings for specific applications. Thorough investigation on the service life of steel tanks with protective coatings or linings has led to the recommendations of the following linings:

Glass-lined: These are normally stocked tanks for water storage up to 82°C, with glass lining to prevent corrosion and addition of rust to water. The glass lining was developed over many years of ceramic research for a wide variety of conditions.

Cement : A special formulation of cement provides excellent corrosion protection. Available on 757 Litres and larger sizes. A manhole or hand hole is included for application of cement lining.

Epoxy : The application of specially formulated epoxy makes this lining suitable for cold or hot water storage. A manhole or handhole is included for application of epoxy lining. Available on 757 Litres and larger sizes.

CATHODIC PROTECTION :Glass-lined, cement and epoxy tanks are furnished with anodes designed for maximum protection.



ACCESSORIES: Tanks will be supplied with the fittings located as indicated on the drawings unless specified otherwise. A manhole or handhole is included on cement or epoxy tanks. A manhole or handhole is optional on glass-lined tanks.

suitable for floor mounting, of specified capacity, one inlet with non-return valve, one outlet with dead weight, pressure reducing valve, stop cock; suitable to work on 230/250-V single phase AC Supply, heating element of specified wattage, thermostat, control fusible plug, pilot lamp etc. ISI mark only and marking of S No. and date of erection. (IS 2082). All Support MS Steel epoxy coated Structure for the tanks. Scope shall also include for grouting of the stands in cement concrete.

Material:

Heating Element: Mineral filled / tubular / copper cord & nickel plated, and conforming to IS: 4159, of specified wattage.

Pilot Lamp: A neon gas field indicating lamp shows functioning of heating elements along with thermostat & thermal cut-out.

Thermostat: A Stem type snap action thermostat, which should cut off the electric supply automatically as per setting of temperature & should be ISI mark.

Thermal Cut-out: In case of thermostat failure this cutout should cut off the electric supply automatically and should restart only on pressing the reset knob.

Pressure Release Valve: If pressure exceeds above 50 psi, it should release the pressure & should be fitted on the inlet pipe.

Dead weight: It will operate when pressure in inside tank increase beyond specified limit.

Fusible plug: Cast aluminium body with threading, and hole for plug with fusible metal. The metal shall be fused, only all the other safeties fails & at high pressure

Hardware: 100x10 mm grouting bolts, MS washers, nuts, etc.

Wall Fasteners: 100x10 mm with vertical cuts, and pin at the centre, washer and nut etc., made of MS. (Similar to Anchor bolt fastener)

30.0 HOT WATER RECIRCULATION PUMPS:

Scope:

The specification covers Supply, installation, testing & commissioning of online Thermostat with Timer based circulation booster pumps at Terrace Level with Requires head directly coupled with the motor with SS casing, SS impeller, SS shaft and driven by 415 V AC, 3 phase, 50 Hz, motor running at 2900 RPM speed and shall be supplied with all accessories viz., base plate, coupling, motor, Antivibration Paid, 2 pole Motor & IE3 Efficiency etc. complete. Panel mounted microprocessor-based pump controller, IP 55 enclosure, shall include the thermostat, required sensors and the timer control panel, ON-OFF and Trip Indicating lamps in each incomer and outgoing feeders. The PLC shall support MODBUS-IP communication for its compatibility to integrate with 3rd party BAS system. PLC shall authorize Read/Write command via BMS., earthing, interlocking arrangement, dry running protection, cascade operation, working / standby selection, with provision of remote on/off operation complete as require. The on/off operations for all pumps shall be available on central BMS system. Each incomer and Outgoing feeder should be capable for protection against Overload, Short Circuit



and Phase reversal condition and shall be capable to communicate with BMS. Scope shall also include supply, laying, termination of power cables of adequate size, and arrangement of cable tray from Pump to Control panel etc. to complete the job. Set of accessories such as GI C Class headers of suction and discharge for (working and Assist by pump assembly) with CED Coating, Cast iron control valves, Cast Iron non return valves, Thermostate, Timer operation, pressure gauge of PN 10 etc. complete the job. Require complete company fitted ready-to-connect packaged system. Pumping system shall be as per GRIHA Norms.

The items/quantities shall be measured and paid upon completion of the linked milestone as per schedule 10 for the respective item.

Construction features:

The major components of the system shall be as follows:

A. PUMP:

Inline vertical multistage pump shall be provided. Variable frequency drive shall be provided with one of the installed pump – if specified in Schedule of quantity.

The pump – motor set and shall be suitable for 3 Ph., 415 V, 50 Hz. AC power supply and having 2900 RPM speed. The pump shall be installed with isolation butterfly valve, non return valve, etc. The detailed specification for pump & motor is as below:

Horizontal Multi stage Pumps

Codes & Standards :

The design and manufacture of the pump shall comply with all currently applicable statutes, regulations and safety codes in the locality where the equipment will be installed.

Design Features:

The pump shall be capable of developing required total head at rated capacity. Impeller shall be closed type and shall be dynamically balanced. The pump shall have non overloading characteristics.

i. Constructional Features:

The casing shall be of rigid construction and shall have side suction and side delivery in case of inline pump and side suction and central delivery in case of submersible centrifugal pump.

The pump shall have very small length suction and delivery pipe connections which will result in minimum friction loss.

Impeller shall be of one piece and shall be of SS CF8 M.

The shaft shall be of S.S. and its surface shall be properly finished.

Shaft sleeves shall be provided to protect shaft from any damage.

Bearing shall be ball or roller type.



Mechanical seal shall be provided to avoid any leakage.

ii. Inspection & Testing:

The pump shall be offered for visual inspection before dispatch.

Material test certificates for the various pump components shall be furnished for purchaser's approval.

Hydrostatic test shall be carried out at 1.5 times the maximum discharge pressure.

All the tests shall be witnessed by purchaser.

iii. Drawings:

Following drawings shall be furnished by the Contractor:

Overall dimensional drawing.

Cross-sectional drawings with all dimension (vertical and horizontal) with Bill of Material and Material of Construction.

iv. Accessories:

The pump shall be provided with all accessories such as base plate, foundation bolts, strainer, pressure gauge, etc. All accessories required for proper and safe operation shall be furnished with the pumps.

v. Pressure transducer:

The system shall be installed with the pressure transducer which shall be set at predetermined pressure to automatically control the pump operation.

vi. Manifolds, Valves, Base frame & Accessories

Suction and Delivery manifolds in Hot Dip Galvanized steel. (80-110micron)
DIN standard flange connections.

One non-return valve and isolating valves for each pump is provided in delivery side and one isolating valve is provided in suction side.

Manifolds and valves are suitable for 16bar pressure rating.

Pumps should be mounted on the common base frame.

Base frame and panel side support is in Galvanized steel.

Suitable range of pressure gauges and pressure transmitter should be connected at the discharge manifolds.

Vibration dampening pad for minimize the noise and vibration in the system.

Concrete foundation as per manufacturer recommendation. (1.5 times X the weight of the Pumping system).

TECHNICAL DATA SHEET pumping system:

Particular	Data to be filled by Contractor
Pump	
Make	
Type & Model: Horizontal Multistage	



Particular	Data to be filled by Contractor
Discharge in cum/hr	
Head (Meters of WC)	
Number of Pumps	
Total system flow (cum/hr)	
Shut off Head (Meters of WC)	
Efficiency (%)	
No. of Stages	
Suction End I.D.	
Delivery End I.D.	
Details of N.P.S.H.	
Vibration Isolation Detail	
Skid Details	
Operating Weight	
Overall Dimension (MM)	
Mechanical Seal Detail	
Material	
Pump Head - Cast Iron	
Pump Base- Cast Iron	
Impeller-SS 304	
Chamber-SS 304	
Shaft-SS316	
Motor stool-Cast Iron	
Shaft seal Cartridge type(SiC/Carbon)	
Rubber parts-EPDM	
Motor	
Make	
Model	
Power Requirement (HP / KW)	
R.P.M.	
No. of pole: 2 pole	
Efficiency class-IE3	
Insulation class-F	
Enclosure class-IP 55	
Supply Frequency-50Hz	
Supply voltage-3X380-415V	
Built in Thermistor-PTC	
Control Panel	
Enclosure class-IP 55	
DETAILS OF PLC	
DETAILS OF VFD	
Pressure Vessel	
Make	
Model Number	
Material of construction (Vessel/Bladder)	
Dimension	
Overall capacity	
Cut-in/Cut-out setting	
Capacity at specified cut-in/cut-out	
Overall dimension of skid mounted system	



Particular	Data to be filled by Contractor
Weight (Static/Dynamic)	
ACCESSORIES & SERVICES REQUIRED	
Base Plate	
Foundation bolts	
Companion flanges	
Spare parts required	
Maintenance tools required	
Cut in pressure	
Cut off pressure	
Plant room suction matching flange & outside plant room flange	
Suction & delivery piping: MS, hot dipped galvanized, Class 'C' with CED Coated	
Suction, delivery valves & header valves: Required, flanged Cast Iron valves with SS internal parts Make : Kirloskar / KSB / AUDCO/ FLOVEL Flanged Ball / Butterfly valve on suction and delivery of each pump & Flanged Non slam, spring operated dual plate type check valve on delivery side of each pump & on header	
Control Panel: With Starter. One pump of similar rating shall have VFD Required with all protections & sequential timer for main pumps Also required Finolex / CCI / Gloster make cable from motor to panel	
Level Transmitter: Required for 0-5 mtr. Range and shall be panel mounted and interlocking with pump	
Pressure Transmitter	
Pressure Gauge: Required at delivery header.	
Gaskets: 'Champion' make	
Hardware: Zinc coated	

31.0 TUBE WELL WATER TREATMENT PLANT:**Scope:**

Supply installation, testing and commissioning of domestic water treatment plant comprising of multigrade sand filter, Activated Carbon filter, Softener etc. according to input water quality/analysis. The scope shall include interconnection piping, valves, instruments, back wash arrangement, including Raw water inlet pumps a 1 working + 1 stand by pump set, and all other required pump Groundfos or ITT lowara make) the pump set is auto operation, including dry run protection, Required Gun Metal Ball Valve & Cast Iron Butterfly valve, interconnecting CPVC piping of suction and discharge header, control panel and other necessary cabling works, 2 pole Motor & IE3 Efficiency etc. complete the job. Panel mounted PLC based pump controller, IP 55 enclosure, ON-OFF and Trip Indicating lamps in each incomer and outgoing feeders, The PLC shall support MODBUS-IP communication for its compatibility to intergrate with 3rd party BAS system. PLC shall authorise Read/Write command via BMS. earthing, interlocking arrangement, dry run protection, cascade operation, working / standby selection, with provision of remote on/off operation complete as require. The on/off operations for all pumps shall be available on central BMS system. Each incomer and Outgoing feeder should be capable for protection against Overload, Short Circuit and Phase reversal condition and shall be capable to



communicate with BMS. Scope shall also include supply, laying, termination of control and power cables of adequate size, and arrangement of cable tray from Pump to Control panel etc. to complete the job.

SITC of electronic type low water level controller with LED panel to operate pump (necessary contacts along with minimum one spare contacts required), with probe & all control wiring to operate the system automatic/manual & shall prevent the pump from dry running. Mounting Height : 500mm from the bottom of tank (RAW UG Tank).

Raw Water Parameters (ppm) / Borewell Water Parameters: Scope shall also include for All borewell all water test parameters (as per Specification) for The designing of Water Treatment Plant.

All Automatic valve to be Electronic operated.

All Pumping system shall be as per GRHA Norms.

Chlorination Dosing System:

The scope includes supply installation testing & commissioning of Chlorination dosing pump, chlorine & tank. This system shall be PID control.

Multi grade filter:

The scope includes supply installation testing & commissioning of Multi Grade Filter, interconnection and other piping, solenoid valve, non return valve, fittings, Air release valve, etc. The Filter shall have auto back wash operation.

Pipe shall be CPVC sch 80. The required length of pipes and fittings up to discharge point shall be provided with necessary fittings.

Activated carbon filter:

The outflow of Multi Grade Filter will further be treated through Activated carbon filter to remove odour & taste.

The scope includes supply installation testing & commissioning of Activated Carbon Filter, interconnection and other piping, solenoid valve, non-return valve, fittings, Air release valve, etc. The Filter shall have auto back wash operation.

Pipe shall be CPVC sch 80. The required length of pipes and fittings up to discharge point shall be provided with necessary fittings.

Softener:

Further, the hardness will be removed by softener.

The scope includes supply installation testing & commissioning of Softener, brine tank, interconnection and other piping, solenoid valve, non-return valve, fittings, Air release valve, etc. The softener shall have automatic regeneration.

Pipe shall be CPVC sch 80. The required length of pipes and fittings up to discharge point shall be provided with necessary fittings.

Interconnecting CPVC SCH 80 piping & instrumentation:



Scope:

The scope includes supply installation testing & commissioning of interconnection piping CPVC SCH 80 & fitting, interconnection and other piping, valve, non-return valve, fittings, Air release valve, etc.

Sr No.	Description	Tender Requirement	Data to be filled by vendor
	Technical Details: -		
A	MGF & ACF Treatment Plant		
1	Filter feed pump		
	Quantity	2(1W + 1S)	
	Flow	23 m ³ /hr	
	Make	As per Approved Make List	
	Head	30-35M	
	Type	Horizontal Centrifugal	
	MOC	SS 316	
	Panel IP	IP 55	
	PLC	Vendor to be provided details	
2	Flow Meter at inlet & outlet		
	Quantity	2 Nos.	
	Type	Electromagnetic	
	Size	as per Vendor	
	Make	As per Approved Make List	
3	Multigrade Sand Filter		
	Quantity	1 No	
	Design Code	IS-2825	
	Flow	23 m ³ /hr	
	Filtration Rate:	18 cum/sqmt/hr	
	Backwash flow rate	as per Vendor	
	Size	1100 MM Dia	
	Media	as per vendor	
	Media Qty.	As per Vendor	
	Media Depth	As per Vendor	
	Shell thickness	As per Vendor	
	Dished end thickness	As per Vendor	
	Bed plate thickness	As per Vendor	
	Top nozzle for chlorine sanitation	Provided with valve,	
	Frontal Pipe	GI C Class with painting two coats of approved shade of enamel paint over a coat of approved primer.	
	Valve	SS Disc, EPDM Seat	
	Side manhole for media removal.	Required	
	MOC	MSEP (Epoxy Coated inside & Outside),	
	Design Pressure	5.0 kg/cm ²	
	Working Pressure	3.5 kg/cm ²	
	Make	Ion Exchange/Thermax/Aakar Engineers/Equivalent	
4	Activated Carbon filter		



Sr No.	Description	Tender Requirement	Data to be filled by vendor
	Quantity	1 No	
	Design Code	IS-2825	
	Flow	23 m3/hr	
	Filtration Rate:	18 cum/sqmt/hr	
	Backwash flow rate	as per vendor	
	Size	1100 MM Dia	
	Media	as per vendor	
	Media Qty.	As per Vendor	
	Media Depth	As per Vendor	
	Shell thickness	As per Vendor	
	Dished end thickness	As per Vendor	
	Bed plate thickness	As per Vendor	
	Frontal Pipe	GI C Class with painting two coats of approved shade of enamel paint over a coat of approved primer.	
	Valve	SS Disc. EPDM Seat	
	Side manhole for media removal.	Required	
	Sampling Cock	Required at Inlet & Outlet	
	MOC	MSEP (Epoxy Coated inside & Outside),	
	Design Pressure	3.0 kg/cm2	
	Working Pressure	3.5 kg/cm2	
	Make	Ion Exchange/Thermax/Aakar Engineers/Equivalent	
5	Softener		
1.0	MAKE	Ion Exchange/Thermax/Aakar Engineers/Equivalent	
2.0	Model	Pl. Furnish	
3.0	Quantity	As per BOQ	
4.0	Capacity	As per BOQ	
5.0	Operation	Automatic	
6.0	Type of Unit	Down Flow	
7.0	Size	As per BOQ	
8.0	M.O.C	MSEP	
9.0	Size of Valve	As per Vendor	
10.0	Size of Piping	As per Vendor	
11.0	Flow Rate	As per BOQ	
12.0	Media Qty	As per Vendor	
13.0	OBR	As per BOQ	
14.0	Brine tank capacity	As per Vendor	
15.0	Brine tank MOC	MSFRP	
16.0	Working Pressure Kg/cm2	Maxi : 3.5 / Mini : 3.0	
17.0	Regeneration	Manual	
18.0	Agitator	100 rpm	
19.0	Agitator Motor	As per vendor	
20.0	Agitator MOC	MSRL	
21.0	ventury.	As per vendor design	



Sr No.	Description	Tender Requirement	Data to be filled by vendor
6	Pressure gauge		
	Quantity	1 lot	
7	TDS/Conductivity meter with Local display & Transmitter (ACF OUTLET)		
	Quantity	1 nos.	
	Type	Line Mounted	
	MAKE	As per Approved Make List	
8	Piping and Valves work		
	Quantity	1 lot	
	Piping MOC	GI C Class with painting two coats of approved shade of enamel paint over a coat of approved primer.	
	Line Sizes	As per Vendor	

32.0 TUBE WELL SUBMERSIBLE PUMP:

Submersible pump set generally comprises of the following:

- a) Pump
- b) Motor
- c) Non Return Valve
- d) Cable & Cable guards

PUMP ASSEMBLY:

This comprises of suction strainer, bowl, shaft, impeller, bearing, discharge casing etc.

Stator winding will be cooled by surrounding water.

Impeller shall be enclosed type and it shall be dynamically balanced.

Pump shaft shall be guided through bearings.

Surface finish of shaft shall be 0.75 mili micron.

The inlet passage of the suction casing shall be streamlined to avoid eddies.

Pump casing shall have provision for securing cable.

Cable guards shall be provided over the cable to prevent any damage.

MOTOR:

Motor shall be squirrel cage, water filled, induction, wet type and shall conform to IS 9283: 1979.

Stator winding will be cooled by surrounding water.

A seal ring and sand slings will be provided to prevent entry of water and sandy particles to the stator tube.

A pressure equalising rubber diaphragm shall be provided in the lower part of the motor to



absorb the expansion of water which will take place due to heat dissipation.

A thrust place shall be provided to take axial thrust of the pump and rotor.

NON RETURN VALVE:

NRV shall be provided to protect piping system in the case of water hammer which shall occur due to power failure.

CABLE:

Cable shall conform to 4.4 of IS 9283 : 1979. This cable shall run along the pump casing. The cable shall be protected by cable guard. The cable shall be PVC insulated copper flat cable.

BORECAP:

It shall be manufactured from M.S. sheet.

CABLE GUARD:

Every pipe joint, flat cable shall be bind with nylon core of (1/16").

CLAMP:

Clamps shall be provided for column pipe and shall be made of heavy duty MS flat

Supplying & erecting approved make Automatic liquid level controller 6A as per instruction of Engineer in charge on site complete with wiring connection, with copper conductor from pump to tank to monitor the liquid level and passes the single to tube well motor for on/off operation

TESTS:

VISUAL INSPECTION:

A pump shall be offered for a visual inspection to the client before despatch.

HYDROSTATIC TEST:

This test shall be carried out at 1.5 times the maximum discharge pressure for an individual casing or for whole assembled pump. The pump shall be tested for operating head range.

DRAWINGS TO BE FURNISHED BY VENDOR:

- 1) Performance curves
- 2) Overall dimensional drawing
- 3) Cross-sectional drawing with Bill of Material and material of construction.

PAINTING AND MARKING:

The pump shall be painted with epoxy paint and properly marked with:

- 1) Manufacturer's Name
- 2) Model No.
- 3) Motor rating
- 4) Discharge at duty point
- 5) Head at duty point
- 6) Overall efficiency at duty point



- 7) Rated speed
- 8) Rated Voltage
- 9) Frequency
- 10) Delivery size

Contractor has to submit the report with the following data :

Static water level of the bore well

Pumping level of bore well

Discharge of Pump in m³/hr.

Ampere meter, Volt meter, Power meter, etc. reading for 4 hour working of submersible pump.

GUARANTEE:

The manufacturer shall give guaranteed minimum efficiency at duty point.

The pump shall be guaranteed by the manufacturer against any defects and workmanship for a period of at least 12 months from the date of commissioning, whichever is less.

SUBMERSIBLE PUMP (DOMESTIC WATER)

Sr. No.	ITEM DESCRIPTION	DATA
1.0	Type of Pump	Submersible Fixed Type
2.0	Mfg. Standard	IS 8034: 1989 with its latest revision
3.0	Fluid	Bore well Water
4.0	PH	As per water test report
5.0	Sp. Gravity	1.0
6.0	Temperature	30 deg. Cent.
7.0	Solid Handling Capacity	Fine Sand Handling
8.0	Pump Detail	
8.1	Quantity	1 No. For Domestic water
8.2	Capacity in Ltr./hr.	As per BOQ
8.3	Head in mtrs.	As per BOQ
8.4	Operating Condition	Continuous
8.5	Rated Speed	2900 RPM
8.6	No. of stages	Minimum preferred
8.7	Method of Lubrication	Self
8.8	Impeller	Semi Open/Enclosed
8.9	Type of seal	Mechanical
8.10	Type of connection	Flanged
8.11	Maximum Outside Diameter	As per mfg. standard
8.12	Overall efficiency at duty point	*
8.13	Foot Valve	Required (One side threaded, other side column pipe flange)



Sr. No.	ITEM DESCRIPTION	DATA
9.0	Motor	
9.1	Rating	*
9.2	Type	Wet Submersible Squirrel Cage Induction
9.3	Mfg. Standard	IS 9283 : 1985 with its latest revision
9.4	Supply Condition	3 Phase, 415 Volts $\pm 10\%$, 50 Hz. $\pm 5\%$, Combined $\pm 10\%$
9.5	Connection	Directly coupled
9.6	Starter	Star / Delta
9.7	Minimum reserve power required at duty point	15%
10.0	Material of Construction	
10.1	Impeller	Bronze IS 318 Gr. LTB2
10.2	Shaft	S.S. AISI 410 or ASTM A276
10.3	Suction Strainer	SS 304
10.4	Pump casing	C.I FG 200 with 1.5 to 2%
10.5	Bearing Bush	Leaded Tin Bronze
10.6	Thrust plate	Bronze
10.7	Bearing Sleeve	S.S. 316
11.0	Cable	
11.1	Standard	IS9283: 1979 Clause 4.4
11.2	Cable type	3 Core water proof flat copper cable
12.0	Drawings	1) Performance curves 2) Overall dimensional drawing

Note : ** denotes information's to be provided by the bidder

33.0 INSTALLATION OF ENGINEERED SUPPORT SYSTEM

Plumbing pipe support from RCC slab

The Plumbing Pipes should be simply supported by Split Clamps. Split Clamps should be pre-galvanised and should have a two-piece arrangement with ribbing reinforced clamp body and two captive tightening bolts, secured with loss washers for non-slipping high load bearing capacity.

The Split clamp should have an EPDM rubber lining which will prevent the direct contact of Pipe with the steel. The rubber lining should have the capacity to reduce the structure borne noise vibration to up to 18 dB and 22dB for waster water pipe.

Pipe clamp should be as per DIN 3576 if support for metal pipe. The support installation should be as per international plumbing code. The Clamp should have the temperature capacity of -50 degree Celsius to +150 degrees Celsius.

In the case of multiple pipes, the supporting arrangement should be made using support channel made up of cold rolled steel of quality DX51 or greater and as per EC3(Eurocode 3) or DIN EN 1993-1-1



The Support channel should be pre galvanised with minimum GSM of 275 and should have universal mounting slot on the front of the rail for accurate positioning of fasteners and system compatible round and long holes on back of the rail.

The Mounting according to static requirements should undertake into account the manufacturer's documents and should be monitored according to RAL - GZ 655-C

The Threaded Rods used for the suspension of the Pipe should be made up of partially annealed medium carbon steel of grade 4.8 strength class and as per DIN 976 standard.

The Drop-in anchors used for the suspension of the rods should be ETA (EUROPEAN TECHNICAL APPROVAL) with CE mark for cracked and un-cracked concrete.

It should be divided into four expansion segments for uniform pressing force distribution in the borehole.

The load bearing capacity for the selection of the split clamp for suitable size of the pipe should be provided by the contractor to the consultant for verification.

Nominal Pipe Dia (mm)	Maximum Support Spacing (m)				Nominal Pipe Dia (mm)	Maximum Support Spacing (m)			
	UPVC Pipe		POLYETHYLENE PIPE Class D, E,6,7			UPVC Pipe		POLYETHYLENE PIPE Class D, E,6,7	
	Horizontal	Vertical	Horizontal	Vertical		Horizontal	Vertical	Horizontal	Vertical
Upto 10	-	0.6	0.3	0.5	65	1.2	1.4	0.6	0.9
15	-	0.6	0.4	0.6	80	1.4	1.5	0.6	0.9
20	-	0.7	0.4	0.6	100	1.5	1.7	0.7	1.1
25	-	0.8	0.4	0.6	125	1.7	1.9	-	-
32	-	0.8	0.5	0.7	150	1.8	2.1	-	-
40	-	0.9	0.5	0.7	175	2.0	2.3	-	-
50	1.1	1.2	0.6	0.9	200	2.1	2.5	-	-

Fig P. Typical Arrangement for plumbing pipe support from RCC slab

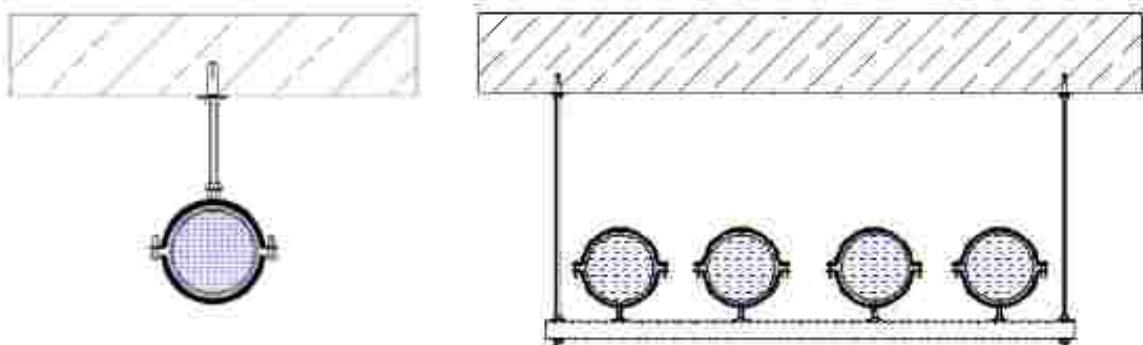

Plumbing pipe support from PEB Structure

The Plumbing Pipes should be simply supported by Split Clamps.

Split Clamps should be pre-galvanised and should have a two-piece arrangement with ribbing reinforced clamp body and two captive tightening bolts, secured with lock washers for non-slipping high load bearing capacity.

The Split clamp should have an EPDM rubber lining which will prevent the direct contact of



Pipe with the steel. The rubber lining should have the capacity to reduce the structure borne noise vibration to up to 18 dB and 22dB for waster water pipe.

Pipe clamp should be as per DIN 3576 if support for metal pipe.
The support installation should be as per international plumbing code.

The Clamp should have the temperature capacity of -50 degree Celsius to +150 degrees Celsius.

In the case of multiple pipes, the supporting arrangement should be made using support channel made up of cold rolled steel of quality DX51 or greater and as per EC3(Eurocode 3) or DIN EN 1993-1-1

The Support channel should be pre galvanised with minimum GSM of 275 and should have universal mounting slot on the front of the rail for accurate positioning of fasteners and system compatible round and long holes on back of the rail.

The Mounting according to static requirements should undertake into account the manufacturer's documents and should be monitored according to RAL - GZ 655-C

The Threaded Rods used for the suspension of the Pipe should be made up of partially annealed medium carbon steel of grade 4.8 strength class and as per DIN 976 standard.

For parallel to beam application.

The Girder cleat for attachment of support channel to steel girder

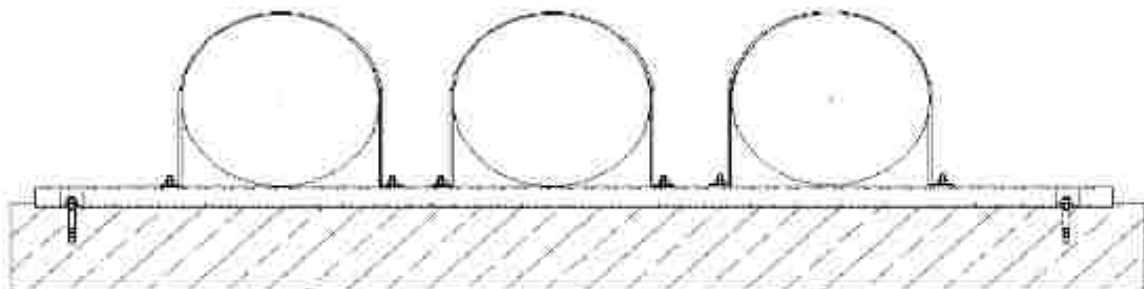

Girder cleat should be Vds approved.
For perpendicular to beam application

The Girder clamp for suspension of threaded pins and threaded rods for support channels.
Girder clamps should be FM and Vds Approved.

The load bearing capacity for the selection of the split clamp for suitable size of the pipe should be provided by the contractor to the consultant for verification.

Nomin al Pipe Dia (mm)	Maximum Support Spacing (m)				Nomin al Pipe Dia (mm)	Maximum Support Spacing (m)			
	UPVC Pipe		POLYETHYLEN E PIPE Class D, E,6,7			UPVC Pipe		POLYETHYLEN E PIPE Class D, E,6,7	
	Horizont al	Vertic al	Horizont al	Vertic al		Horizont al	Vertic al	Horizont al	Vertic al
Upto 10	-	0.6	0.3	0.5	65	1.2	1.4	0.6	0.9
15	-	0.6	0.4	0.6	80	1.4	1.5	0.6	0.9
20	-	0.7	0.4	0.6	100	1.5	1.7	0.7	1.1
25	-	0.8	0.4	0.6	125	1.7	1.9	-	-
32	-	0.8	0.5	0.7	150	1.8	2.1	-	-



40	-	0.9	0.5	0.7	175	2.0	2.3	-	-
50	1.1	1.2	0.6	0.9	200	2.1	2.5	-	-

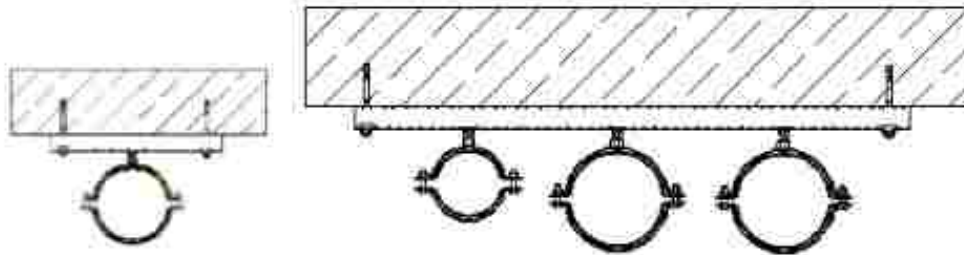

Plumbing pipe support from Terrace

The Plumbing Pipes should be simply supported by Split Clamps.

Split Clamps should be pre-galvanised and should have a two-piece arrangement with ribbing reinforced clamp body and two captive tightening bolts, secured with loss washers for non-slipping high load bearing capacity.

The Split clamp should have an EPDM rubber lining which will prevent the direct contact of Pipe with the steel. The rubber lining should have the capacity to reduce the structure borne noise vibration to up to 18 dB and 22dB for waster water pipe. Pipe clamp should be as per DIN 3576 if support for metal pipe.

The support installation should be as per international plumbing code.

The Clamp should have the temperature capacity of -50 degree Celsius to +150 degree Celsius.

In the case of multiple pipes, the supporting arrangement should be made using support channel made up of cold rolled steel of quality DX51 or greater and as per EC3(Eurocode 3) or DIN EN 1993-1-1.

The Support channel should be pre galvanised with minimum GSM of 275 and should have universal mounting slot on the front of the rail for accurate positioning of fasteners and system compatible round and long holes on back of the rail.

The Mounting according to static requirements should undertake into account the manufacturer's documents and should be monitored according to RAL - GZ 655-C.

In the case of pipe sizes beyond 4" for the steel pipe, it should be clamped with either a Split pipe clamp with all round welded nut or by using a Pipe strap.

The Threaded Rods used for the fixing Pipe clamp with channel that should be made up of partially annealed medium carbon steel of grade 4.8 strength class and as per DIN 976 standard. The Drop-in anchors or stud anchor used for the channel fixing with terrace that should be ETA(EUROPEAN TECHNICAL APPROVAL) with CE mark for cracked and un-cracked concrete.

It should be divided into four expansion segments for uniform pressing force distribution in the borehole.

The load bearing capacity for the selection of the split clamp for suitable size of the pipe should be provided by the contractor to the consultant for verification.

Nominal Pipe Dia	Maximum Support Spacing (m)		Nominal Pipe Dia (mm)	Maximum Support Spacing (m)	
	UPVC Pipe	POLYETHYLENE PIPE		UPVC Pipe	POLYETHYLENE PIPE Class D,



(mm)	Class D, E,6,7					E,6,7			
	Horiz ontal	Verti cal	Horizo ntal	Verti cal		Horiz ontal	Verti cal	Horizo ntal	Vertica l
Upto 10	-	0.6	0.3	0.5	65	1.2	1.4	0.6	0.9
15	-	0.6	0.4	0.6	80	1.4	1.5	0.6	0.9
20	-	0.7	0.4	0.6	100	1.5	1.7	0.7	1.1
25	-	0.8	0.4	0.6	125	1.7	1.9	-	-
32	-	0.8	0.5	0.7	150	1.8	2.1	-	-
40	-	0.9	0.5	0.7	175	2.0	2.3	-	-
50	1.1	1.2	0.6	0.9	200	2.1	2.5	-	-

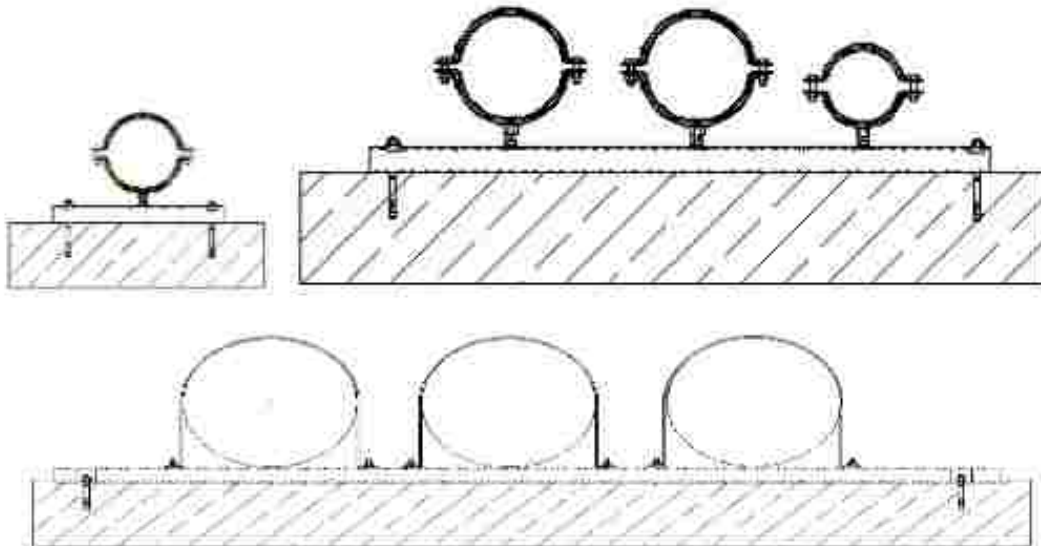

Plumbing pipe support from Wall

The Plumbing Pipes should be simply supported by Split Clamps.

Split Clamps should be pre-galvanised and should have a two-piece arrangement with ribbing reinforced clamp body and two captive tightening bolts, secured with lock washers for non-slipping high load bearing capacity.

The Split clamp should have an EPDM rubber lining which will prevent the direct contact of Pipe with the steel. The rubber lining should have the capacity to reduce the structure borne noise vibration to up to 18 dB.

Pipe clamp should be as per DIN 3576 if support for metal pipe.

The support installation should be as per international plumbing code.

The Clamp should have the temperature capacity of -50 degree Celsius to +150 degree Celsius.

In the case of multiple pipes, the supporting arrangement should be made using support channel made up of cold rolled steel of quality DX51 or greater and as per EC3(Eurocode 3) or DIN EN 1993-1-1

The Support channel should be pre galvanised with minimum GSM of 275 and should have universal mounting slot on the front of the rail for accurate positioning of fasteners and system compatible round and long holes on back of the rail.

The Mounting according to static requirements should undertake into account the manufacturer's documents and should be monitored according to RAL - GZ 655-C.



In the case of pipe sizes beyond 4" for the steel pipe, it should be clamped with either a Split pipe clamp with all round welded nut or by using a Pipe strap.

The Threaded Rods used for the fixing Pipe clamp with channel that should be made up of partially annealed medium carbon steel of grade 4.8 strength class and as per DIN 976 standard.

The Drop-in anchors or stud anchor used for the channel fixing with terrace that should be ETA(EUROPEAN TECHNICAL APPROVAL) with CE mark for cracked and un-cracked concrete.

It should be divided into four expansion segments for uniform pressing force distribution in the borehole.

The load bearing capacity for the selection of the split clamp for suitable size of the pipe should be provided by the contractor to the consultant for verification.

Nominal Pipe Dia (mm)	Maximum Support Spacing (m)				Nominal Pipe Dia (mm)	Maximum Support Spacing (m)			
	UPVC Pipe		Polyethylene Pipe Class D, E,6,7			UPVC Pipe		Polyethylene Pipe Class D, E,6,7	
	Horizontal	Vertical	Horizontal	Vertical		Horizontal	Vertical	Horizontal	Vertical
Upto 10	-	0.6	0.3	0.5	65	1.2	1.4	0.6	0.9
15	-	0.6	0.4	0.6	80	1.4	1.5	0.6	0.9
20	-	0.7	0.4	0.6	100	1.5	1.7	0.7	1.1
25	-	0.8	0.4	0.6	125	1.7	1.9	-	-
32	-	0.8	0.5	0.7	150	1.8	2.1	-	-
40	-	0.9	0.5	0.7	175	2.0	2.3	-	-
50	1.1	1.2	0.6	0.9	200	2.1	2.5	-	-

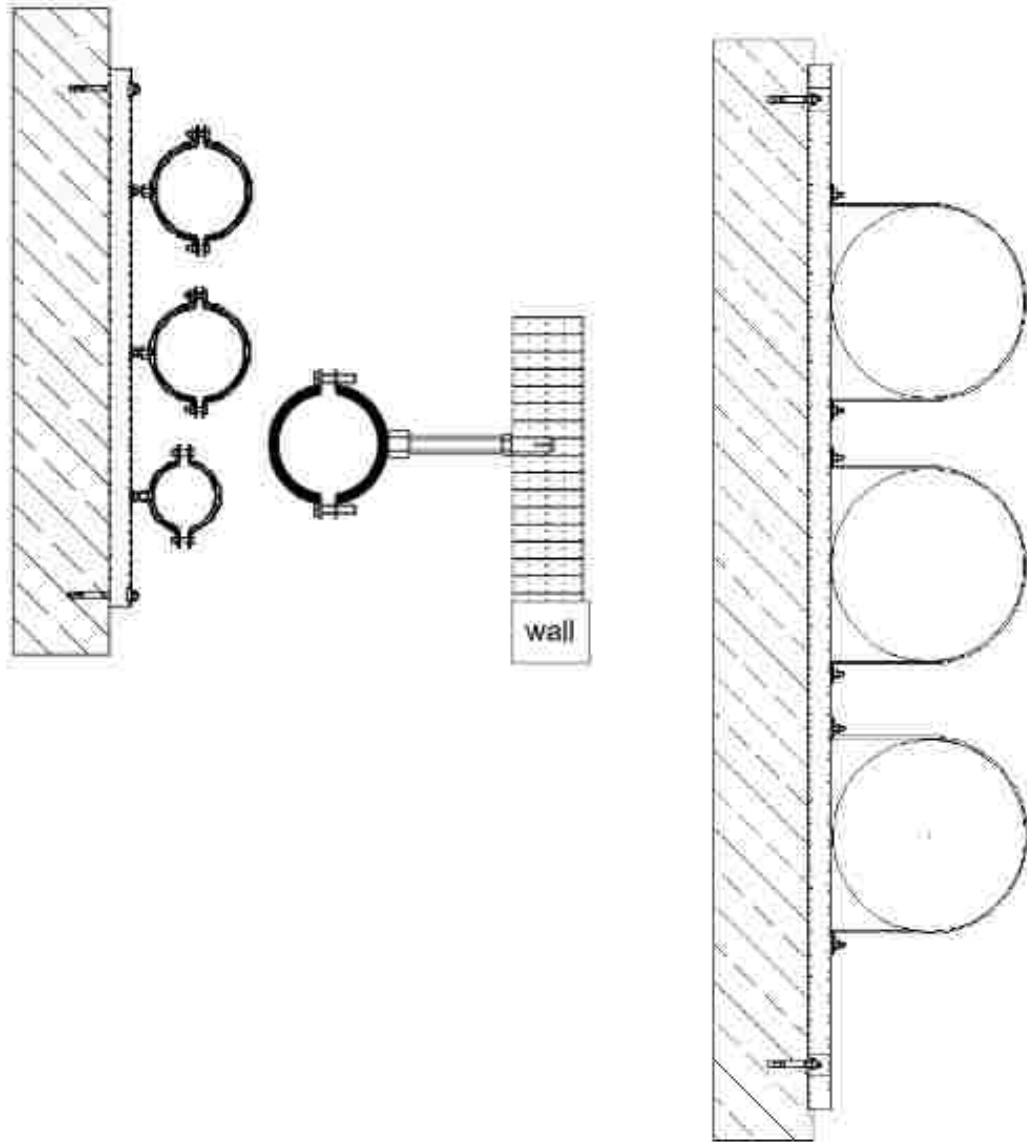

34.0 PLUMBING LIST OF APPROVED MAKES

Signature of Bidder



Sr. No.	ITEM	APPROVED MAKE
01	CP Grating (P Trap)	Chilly/Futura/Jayna/Hightech/Kich/ Tece/ Viking/ Euronics
02	Ball Valve	Sant/Zoloto/Leader/Honeywell/Normax
03	Gun Metal Wheel Valve	Sant/Zoloto/Leader/Honeywell
04	Pressure Reducing Valve	Sant/Zoloto/Leader/Honeywell
05	Butterfly Valve	Sant/ Zoloto/ Leader/ Audo / Kitz / L&T / Kirloskar / Intervolve /Honeywell
06	Non-Return Valve	Sant/Zoloto/Leader/ Kirloskar /Normax /Honeywell
07	Cast Iron Manhole Cover	Kapilansh/Neco/Kejriwal
08	Cast Iron Grating	Kapilansh/Neco/Kejriwal
09	Upvc Pipes/Fittings	Astral / Supreme / Prince / Ashirvad
10	Cpvc Pipes/Fittings	Astral / Supreme / Prince / Ashirvad
11	Pvc Pipes/Fittings	Astral / Supreme / Finolex / Prince/ Ashirvad/ Dutron
12	Ductile Iron/Cast Iron Pipes/Fittings	Jindal / Tata / Reliance / Saint Gobain/ Kejriwal / Electrosteel / Kejriwal
13	Minerally Reinforced Polypropylene High Density Low Noise Pipe	Huliot/Geberit/ Wavin/ Astral
14	Water Meter	Elster / Itron (Actris) / Zener / Sappie Sant / Kranti / Capstan / Honeywell / Adm
15	Water Level Indicator	Sant / Sigma / Gelco / Honeywell / Abb / E+H / Krohne / Siemens / Vega / Emerson
16	Hydro Pneumatic System	Franklin/Grundfos/Xylem/Ksb/Kirloskar/Wilo/Lubi
17	Water Softener System	Pentair/Ion Exchange/ Powerh2o/Gopani/Cleantech/
18	Submersible Pumps	Grundfos/Xylem/Ksb/Kirloskar/Wilo/Lubi/ CG / Jyoti
19	Non Clog Submersible De Watering Pump	Grundfos/Xylem/Ksb/Kirloskar/Wilo/Lubi/ CG / Jyoti
20	Mud Pump For Drainage	Grundfos/Xylem/Ksb/Kirloskar/Wilo/Lubi/ CG / Jyoti
21	Domestic Ro System	Pentair/Ion Exchange/Powerh2o/ Gopani/Cleantech
22	Water Cooler	Blue Star/Voltas/Usha/ Eureka Forbes
23	Electric Geyser	Jaquaz/Ao Smith/Venus/Bajaj / Havells
24	Ball Float Valve	Prayag / Zoloto
25	Sewage Treatment Plant	Shubham India/IP Projets /Ion Exchange/Askar Engineers/
26	Domestic/ Rain Water Treatment Plant	Shubham India/Thermax/Ion Exchange/Askar Engineers/Eno Fluidtek Pvt Ltd
27	Dwc Pipe	Astral/ Gemini/ Supreme / Noble/ Prince
28	Motor	Abb/Bbl/Bhel/Cgl / Siemens / Kco / /Havells
29	Hdpe Pipe	Ril / Sanghir / Dutron / Supreme / Reliance
30	Rec Hume Pipes External Main Under Ground Pipe	Indian Hume Pipe/Pranali/Alcock
31	C.I. Pipe & Fittings	Neco/Bengal Iron /Electrosteel/Kejriwal/ Kapilansh /



Sr. No.	ITEM	APPROVED MAKE
32	Frp Manhole Cover	Everesti/Thermodrain/Hp International/Sintex
33	Mz/G.I Pipes	Tata / Jindal / Asian
34	G.I Pipes Fittings Water Supply	Zoloto / Ambika / Tata / Surya / Jindal / Asian
35	Gi To Gi Joints	Champion/Crown/Diamond / Ambika / Tata / Surya / Jindal / Asian
36	Tar	Shalibond/Tikibond-Bs/Swastik
37	External Hot Water Pipe Insulation Component: EPDM	ALP/Aeroflex/ Armaflex/ Aerocell
38	Solvent Cement	Supreme/Finolex/Astral / Prince
39	Starter	Siemens / L&T / Abb / Ab / Schneider / Denfoss / Hitachi / Keb
40	Pressure Gauge	Bells/H Guru/Denfoss / Baumer / H.Guru / Bells / Manometer / Gic
41	Water Transfer Pump	Grundfoss / Xylem / Kirloskar/ Ksb /Wilo Mather And Platt
42	Metallic Expansion Bellows	Bellow Flex/Precision/Dhruv/B.D. Engr.
43	Cables	Finolex / Havells / Rr Kabel / Polycab
44	Uv	Bio Uv / Atg Uv / Trojan Uv / Ultraaqua / Xylem / Alpha / Eureka Forbes / Sukrut
45	Rainy Filter	Neerain/Rainy/Approved Equivalent As Approved By Eic
46	Sluice Gate	Jash / Ivc / Bic / Yashwant
47	Air Release Valve	Kirloskar / Ivc / Intervalve / Audco / Zoloto/R.B.
48	Gully Trap	Perfect/Rk/Anand
49	Slot Drain	Fuji/Aco/Approved Equivalent As Approved By Eic
50	Air Vent Valve	Avk / Kirloskar / Jainsons Industries (Jsi) / Sant / Zoloto
51	Pipe Support, Hangers	Intello Tech/Camry/Hilti/Fischer
52	Ss Pipe	Tata / Jindal / Reliance / Remi / Ratnamani
53	Strainer	Ksb / Kitz / Emerald / Amiad / Gopani / Ansys / Hy-Precision / 3m Cuno
54	Electromagnetic Flow Meter	Honeywell / E&H / Abb / Khrose Marshall / Siemens
55	Heat Pump (Air To Water)	Solahart/Ao Smith/Benchmark/Suntech.
56	Percolation Well	Furatt/Vardhman/Space Element.
57	Loft Tank (Hdpe)	Sintex/Supreme/National
58	Solid Waste Composter	Des Techno/Smart Enviro/Envicare/Greenera Engineering
59	Bins & Container	Sintex/Niltamal/Supreme
60	Membrane	Ge / Torray / Dow / Hydranotic / Dupont
61	Hot Water Recirculation Pump	Franklin / Grundfos / Xylem / Kbl / Ksb/Wilo
62	Sanitary Fixtures and Fittings	Astral/ Jaquar/Euronics / Cera
63	Grease Interceptor	ACO, Wade, Ashirvad, Supreme



SECTION IV
TECHNICAL SPECIFICATIONS
Part B: - Sanskar Kendra Plaza

PLUMBING TENDER DOCUMENT

TECHNICAL SPECIFICATION



TECHNICAL SPECIFICATION

Contents

1.0	SANITARY FIXTURES & C.P. FITTINGS:.....	3
2.0	INTERNAL DRAINAGE (SOIL, WASTE, VENT AND RAINWATER PIPES).....	7
3.0	TRAPS	10
4.0	TERRACE RAINWATER KHURRA, INLET MOUTH	11
5.0	DWC POLYETHYLENE PIPE.....	11
6.0	INTERCEPTING TRAP	16
7.0	PERCOLATION WELL & TUBEWELL:.....	16
8.0	CHLORINATED POLYVINYL CHLORIDE (CPVC) PIPES	27
9.0	PLUMBING INSULATION FOR HOT WATER SUPPLY	32
10.0	SWR - UPVC PIPES & FITTINGS.....	34
11.0	BALL VALVES (FLOAT VALVE):	36
12.0	BUTTERFLY VALVES	36
13.0	FLOT VALVE	42
14.0	REFLUX VALVE (NON-RETURN VALVE).....	42
15.0	Y -STRAINER	45
16.0	GREASE TRAP	46
17.0	AIR RELEASE VALVE.....	46
18.0	BLANK FLANGE.....	47
19.0	GARDEN HYDRANT AND GARDEN HOSE PIPE	47
20.0	WOLTMAN TYPE BULK WATER METER- AMR BASED.....	47
21.0	MOSQUITO PROOF GRATING.....	48
22.0	R.C.C. PIPES	48
23.0	HYDROPNEUMATICS SYSTEM:.....	57
24.0	DRINKING WATER TREATMENT PLANTS.....	62
25.0	SS STORAGE TANK:.....	63
26.0	WATER COOLER WITH RO	63
27.0	BOREWELL DOMESTIC WATER TREATMENT PLANT	65
28.0	DEWATERING PUMP FOR SUMP DRAIN:	67
29.0	AIR TO WATER HEAT PUMP	69
30.0	HOT WATER RECIRCULATION PUMPS:.....	72
31.0	TUBE WELL WATER TREATMENT PLANT:.....	76
32.0	TUBE WELL SUBMERSIBLE PUMP:	80
33.0	INSTALLATION OF ENGINEERED SUPPORT SYSTEM.....	84

TECHNICAL SPECIFICATION

DETAILED SEPCIFICATIONS FOR PLUMBING WORK

1.0 SANITARY FIXTURES & C.P. FITTINGS:

Scope

Work under this section shall consist of transportation, furnishing, installation, testing and commissioning and all labor as necessary as required to completely install all sanitary fixtures, brass and chromium plated fittings and accessories as required by the drawings and specified hereinafter or given in the Bill of Quantities.

General Requirements

All fixtures and fittings shall be fixed with all such accessories as are required to complete the ITEM in working condition whether specifically mentioned or not in the Bill of Quantities, specifications, drawings or not.

All fixtures and accessories shall be fixed in accordance with a set pattern matching the tiles or interior finish as per architectural design requirements. Wherever necessary the fittings shall be centered to dimensions and pattern desired.

Fixing screws shall be half round head chromium plated brass with C.P. washers wherever required as per directions of Authority's Representative.

All fittings and fixtures shall be fixed in a neat workmanlike manner true to levels and heights shows on the drawings & in accordance with the manufacturer's recommendations. Care shall be taken to fix all inlet and outlet pipes at correct positions.

All fixtures of the similar materials shall be by the same manufacturers.

All fitting shall be of the chromium plated materials.

Without restricting to the generally of the foregoing the sanitary fixtures shall include all sanitary fixtures, C.P. fittings and accessories etc. necessary and required for the building.

Whether specifically mentioned or not all fixtures and appliances shall be provided with approved fixing devices, nuts, bolts, screws, and hangers as required. These supports shall have the necessary adjustment to allow for irregularities in the building area construction.

For the installation of the CP fittings, Teflon tape shall be used.

European W.C.

European W.C. of glazed vitreous china shall be wash down, single or double symphonic type, floor or wall mounted set, flushed by means of flush valve as specified in Bill of Quantities. Flush pipe / bend shall be connected to the W.C. by means of suitable rubber adopter. Wall hung W.C. shall be supported by C.I. floor mounted chair.

Each W.C. seat cover shall be so fixed that it remains absolutely stationary in vertical position without falling down on the W.C. Seat cover shall be of white solid plastic.

TECHNICAL SPECIFICATION

elongated open front with heavy duty hinges. Exposed fixture trims shall be Chrome plated, and trims of similar function shall be by the same manufacturer.

Flushing cistern to be used shall conform to the requirements of IS: 774-2004. High level cisterns shall be of cast iron unless otherwise specified. Low level cistern shall be of the same material as the water closet or as instructed by the D.T.A./Authority. The cisterns shall be mosquito proof & shall fulfil the requirements of the local Authority.

If alternatively Flush valves to be used, then shall be of the best approved quality procurable with C.P. control valve and C.P. flush pipe.

The flush pipe/bend shall be connected to the WC by means of a suitable rubber adopter.

Flushing cistern to be used shall conform to the requirements of IS: 774-2004. High level cisterns shall be of cast iron unless otherwise specified. Low level cistern shall be of the same material as the water closet or as instructed by the D.T.A./Authority. The cisterns shall be mosquito proof & shall fulfil the requirements of the local Authority.

The levels of the WC should be checked by placing spirit level on the W.C. W.C. should be tested on completion of fixing by putting small paper balls and flushing out. If all the paper balls are not flushed out. The fixing will have to be rectified / re-aligned.

Wash Basins

Wash basin shall be of white vitreous china of best quality manufactured by an approved firm and sizes as specified in the Bill of Quantities.

Wash basin shall be of under counter drop in type shall be supported on a pair of rolled steel brackets of approved design and shall be mounted on a countertop. So that rim and basin bowl is exposed from top.

Wash basin shall be provided with single lever mixer with chain and rubber plug, chromium plated brass bottle trap of approved quality, design and make where hot water required. Single tap where hot water is not required.

Wash basin shall be fixed at proper location and height and truly horizontal as shown on drawing or as directed by Authority's Representative.

Urinals

Half stall wall hung urinals of glazed vitreous china shall be provided with 15mm dia, C.P. brass spreader, 32/40/50mm dia C.P. domical waste and C.P. cast brass bottle trap with pipe and wall flange and shall fixed to wall by one C.I. bracket and two C.I. clips as recommended by manufacturers complete as directed by the Authority's Representative.

Urinals shall be flushed by means of "NO-TOUCH" infrared operated flush valves. Urinal Sensor have Sensotronic Concealed Type Flushing Valve for Urinal Complete Set with Installation Box with Control Cock.

Waste pipes for urinals shall be any one of the given materials as directed by the Authority's Representative:

TECHNICAL SPECIFICATION

A. G.I. Pipes

B. Rigid PVC/High density polyethylene.

C. Waste pipes may be exposed on wall or concealed in chase as directed by the Authority's Representative.

Paper Holder

Toilet recessed type paper holder complete in all respects including cutting and making good the walls etc.

BIB Cock

These shall be of C.P. brass bib cocks of best quality necessary fittings with wall Flange etc. complete in all respects including cutting and making good the walls etc.

Angle Valve

These shall be of C.P. brass angle valve with C.P. copper connecting pipe 450 mm long and nuts, washer and brass flange complete, including cutting and making good the wall where required.

Liquid Soap Container

These shall be of C.P. brass liquid soap container of best quality etc. complete in all respects including cutting and making good the walls etc. These shall be fixed by means of stainless-steel screws to wooden / plastic cleats firmly embedded in the wall.

Kitchen / Pantry Sinks

Sinks shall be of stainless-steel material as specified in the Bill of Quantities/Drawings. Each sink shall be provided with R. S. brackets and clips and securely fixed. Countertop sinks shall be fixed with suitable angle iron clips or brackets as recommended by the manufacturer. Each sink shall be provided with 40 mm dia Chromium Plated waste with chain and plug or P.V.C. waste with Escutcheon plates. Fixing shall be done as directed by Authority's Representative.

Supply fittings for sinks shall be mixing fittings or C.P. taps, angle cocks etc. all as specified in the Bill of Quantities/Drawings.

Braided Hose Copper Pipe

Providing and fixing of C.P. copper connecting pipe 450 mm long and nuts, washer and brass flange complete, including cutting and making good the wall where required etc. complete as per directed by the Engineer's Representative.

Pressmatic Pillar Cock

TECHNICAL SPECIFICATION

Providing and fixing Pressmatic Pillar Cock of best quality necessary fittings with wall Flange etc. complete in all respects including cutting and making good the walls etc. complete as per directed by the Engineer's Representative.

Sink Cock

Sink cock of best quality necessary fittings with wall Flange etc. complete in all respects including cutting and making good the walls etc.

Health Faucet

Hand Shower (Health Faucet), with 8mm Dia, 1 -1.2 mtr Long flexible Tube and Wall Hook with accessories of best quality necessary fittings with wall Flange etc. complete in all respects including cutting and making good the walls etc.

Hand Dryer

Hand dryer, fully automatic type, cover shall be fabricated in extra heavy duty 18 gauge type 304 SS/ ABS with exposed surfaces satin finished, the unit shall deliver not less than 71 l/sec of hot air and electrical rating shall be 240 V / 1 phase / 50 cycles.

Urinal Partition

Providing and fixing Urinal partition with frosted glass approx. size 900 MM (H) X 450 MM (W) having 10 MM of glass thickness, including fixing to wall with suitable brackets all as per manufacturers specification etc

Automatic Fragrance Dispense

These shall be of C.P. brass Automatic Fragrance Dispense fixed to wooden cleats with C.P. brass screws complete the item.

Quote & Hat Hook

These shall be of C.P. brass twin way QUOTE and hat hooks fixed into wall with C.P. Brass screws and wall plugs etc. complete including cutting and making good the walls etc.

Grab Bar

grab bar fabricated seamless stainless steel tube in bath room with non-slip gripping surface, polished wall flange at end of bars with heavy duty anchor fasteners and accessories etc complete the job.

Recessed convertible paper towel dispenser and waste receptacle

Item shall be Type-304 stainless steel with welded construction; exposed surfaces shall have satin finish. Flange shall be drawn and beveled, one-piece, seamless construction. Door shall be secured to cabinet with a full-length stainless steel piano-hinge and equipped with a semi-concealed tumbler lock keyed like other Bobrick washroom accessories. Paper towel dispenser shall dispense 600 C-fold or 800 multifold paper towels. Removable waste

TECHNICAL SPECIFICATION

receptacle shall be secured to cabinet with a tumbler lock, have front and side edges of bottom and all top edges hemmed for safe handling, and shall have a minimum capacity of 12-gal. (45.5-L).

2.0 INTERNAL DRAINAGE (SOIL, WASTE, VENT AND RAINWATER PIPES)

Scope

- A. Work under this section shall consist of furnishing all labor, materials, equipment and appliances necessary and required to completely install all soil, waste, vent and rainwater pipes as required by the drawings, specified here in after and given in the Bill of Quantities.
 - a. Without restricting to the generality of the foregoing, the soil, waste, vent and rainwater pipes system shall include the followings: -
 - i. UPVC vertical and horizontal soil waste and vent pipes, rainwater pipes and fittings, joints clamps and connections to fixtures.
 - ii. Floor traps, floor drain clean out plugs, inlet fittings and rainwater roof drain, area/local drains, trench drain.
 - iii. Waste pipes connections from all fixtures e.g., wash basins, sinks, kitchen equipment.
 - iv. Testing of all pipes.
 - v. Connection of main.

General Requirements

- A. All materials shall be new of the best quality conforming to specifications and subject to the approval of Authority's Representative.
- B. Pipes and fittings shall be fixed truly vertical, horizontal or in slopes as required in a neat workmanlike manner.
- C. Pipes shall be fixed in a manner as to provide easy accessibility for repair and maintenance and shall not cause obstruction in shafts, passages etc.
- D. Pipes shall be securely fixed to walls by suitable clamps at intervals specified.
- E. Access doors for fittings and cleanouts shall be so located that they are easily accessible for repair and maintenance.
- F. All works shall be executed as directed by Authority's Representative.

A. UPVC pipes and fittings

The pipes shall be round and shall be supplied in straight lengths with socketed ends. The internal and external surfaces of pipes shall be smooth, clean, and free from grooving and other defects. The ends shall be cleanly cut and square with the axis of the pipe. The pipes shall be designated by external diameter and shall conform to IS: 4985 – 2000.

TECHNICAL SPECIFICATION

Fittings

Fittings shall be of the same make as that of pipes, injection moulded and shall conform to Indian Standard.

Laying and Jointing

The pipes shall be laid and clamped to wooden plugs fixed above the surface of the wall. Alternatively plastic clamps of suitable designs shall be preferred. Provision shall be made for the effect of thermal movement by not gripping or disturbing the pipe at supports between the anchors for suspended pipes. The supports shall allow the repeated movements to take place without abrasion.

Jointing for UPVC pipes shall be made by means of solvent cement for horizontal lines and 'O' rubber ring for vertical line. The type of joint shall be used as per site conditions/direction of the Authority's Representative. Where UPVC pipes are to be used for rainwater pipes, the pipe shall be finished with G.I. adapter for insertion in the R.C.C. slab for a waterproof joint complete as directed by Authority's Representative.

Supports

UPVC pipes require supports at close intervals. Recommended support spacing for unplasticised PVC pipes is 1400 mm for pipes 50 mm dia. and above. Pipes shall be aligned properly before fixing them on the wooden plugs with clamps. Even if the wooden plugs are fixed using a plumb line, pipe shall also be checked for its alignment before clamping, piping shall be properly supported on, or suspended from clamps, hangers as specified and as required. The Contractor shall adequately design all the brackets, saddles, anchors, clamps and hangers and be responsible for their structural sufficiency. Pipe supports shall be primer coated with rust preventive paint.

Repairs

While temporary or emergency repairs may be made to the damaged pipes, permanent repairs should be made by replacement of the damaged section. If any split or chip out occurs in the wall of the pipe, a short piece of pipe of sufficient length to cover the damaged portion of the pipe is cut. The sleeve is cut longitudinally and heated sufficiently to soften it so that it may be slipped over the damaged hard pipe.

Testing

All lengths of PVC rainwater pipes shall be fully tested for water tightness by means of water test maintained for not less than 30 minutes. All pipes shall be subjected to a test pressure of at least 1.5 meter head of water head. The test pressure shall, however, not exceed 6 meter head at any point. The pipes shall be plugged preferably with standard design plugs with rubber plugs on both ends. The upper end shall, however, be connected to a pipe for filling with water and getting the required head.

B. Waste pipe from Appliance

a. Waste pipe from appliances e.g., wash basins, sinks, urinals, chrome plate where seen

TECHNICAL SPECIFICATION

water coolers shall be of uPVC rigid pvc pipe.

- b. All pipes shall be fixed in gradient towards the outfalls of drains. Pipes inside a toilet room shall be in chase unless otherwise shown on drawings. Where required pipes may be run at ceiling level in suitable gradient and supported on structural clamps. Spacing for clamps for such pipes shall be as follows:

	Vertical	
Horizontal		
P.V.C. Pipes	180 cms	120 cms

C. Measurements

Waste/soil, waste, vent and rainwater pipes shall be measured over all along the centre line correct to a centimeter including all fittings along its length. The rate for these pipes shall be inclusive of all fittings, holder bar clamps, lead caulked joint for C.I. and cement joints for UPVC and all other items described in the Bill of Quantities. The portion of the pipe within the collar for C.I./UPVC pipe at the joint shall not be included in the length of the pipe work.

D. SWR uPVC Pipes and fittings

Soil, waste, vent SWR Ring Fit/Solvent pipes with socket and spigot. All pipes shall be straight and smooth and inside free from irregular bore, blow holes, cracks and other manufacturing defects. These pipes conform to EN 1329 / IS 13592 (SWR type B) and are designed to withstand continuous internal hydraulic pressure of 6 Kg/cm to ensure life-long trouble-free working. The pipes are provided with an integral rubber ring type socket at one end while the other end is kept plain, smooth and free from burrs. Rubber ring type socket ends provide easy push – fit type jointing. Simultaneously, allowance for thermal expansion can also be provided during installation.

Fittings

Fittings shall conform to the corresponding Indian Standard as for pipes. Contractor shall use pipes and fittings of matching specification.

Access door shall be secured air and watertight with 3mm thick insertion rubber washer and white lead. The bolts shall be lubricated with grease or white lead for easy removal.

Jointing

1) Rubber Seal Rings for Joints & Access Doors

Manufactured in accordance with IS: 5382 for 75 mm / 90 mm / 110 mm sizes. These are made out of natural rubber with a shore 'A' hardness of 40 × 5. Provide superior resistance to biological attack. Special design of cross section ensures perfect sealing.

2) Lubricant

Available in 100 gms, 250 gms & 500 gms packing. Specially formulated for compatibility with rubber seal as well as PVC. Does not support the growth of bacteria or fungi.

TECHNICAL SPECIFICATION

E. Pipe, Hangers, Support, Clamp, Bracket etc.

Supports

UPVC pipes require supports at close intervals. Recommended support spacing for unplasticized PVC pipes is 1400 mm for pipes 50 mm dia. and above. Pipes shall be aligned properly before fixing them on the wooden plugs with clamps. Even if the wooden plugs are fixed using a plumb line, pipe shall also be checked for its alignment before clamping. Piping shall be properly supported on, or suspended from clamps, hangers as specified and as required. The Contractor shall adequately design all the brackets, saddles, anchors, clamps and hangers and be responsible for their structural sufficiency. Pipe supports shall be primer coated with rust preventive paint.

Testing

Before the system is put into use, it should be tested for leakages by air test, hydraulic test or smoke test.

3.0 TRAPS

1) FLOOR TRAPS/P-TRAP

Floor traps/P-TRAP shall be PVC deep seal with an effective seal of 50 mm. The trap and waste pipes shall be set in cement concrete blocks firmly supported on the structural floor. The blocks shall be in 1:2:3 mix (1 cement: 2 coarse sand: 4 stone aggregate 20 mm nominal size) mixed with water proof compound and extended to 40 mm below finished floor level. Contractor shall provide all necessary shuttering and centering for the blocks. Size of the block shall be 30 x 30 cms of the required depth. The trap shall be installed at lowest point ensure no pending occurs at perimeters of the drain.

2) MULTI FLOOR TRAPS/P-TRAP

Floor traps/P-TRAP shall be Low noise (PP), deep seal with an effective seal of 50 mm. The trap and waste pipes shall be set in cement concrete blocks firmly supported on the structural floor. The blocks shall be in 1:2:3 mix (1 cement: 2 coarse sand: 4 stone aggregate 20 mm nominal size) mixed with water proof compound and extended to 40 mm below finished floor level. Contractor shall provide all necessary shuttering and centering for the blocks. Size of the block shall be 30 x 30 cm of the required depth. The trap shall be installed at lowest point ensure no pending occurs at perimeters of the drain.

Floor Trap Inlet

Bathroom traps and connections shall ensure free and silent flow of discharging water. Where specified, the Contractor shall provide a special type of galvanised iron Inlet fitting without or with one, two or three Inlet sockets to receive the waste pipe. Joint between waste and fitting shall be connected to a C.I. 'P' or 'S' trap with at least 50mm seal (Hopper and traps shall be paid for separately). Floor trap inlet fittings and the trap shall be set in cement concrete blocks.

C.P./Stainless Steel Gratings

TECHNICAL SPECIFICATION

Providing & fixing PVC SWR TYPE B P Trap of 110 X 110 mm diameter with Height riser/ necessary 110MM Diameter of distance piece for wash basin/ sink drain connection with cockroach trap - square flat cut, Satin-matt finish - 150mm x 150mm of approved Make, making necessary slab/ wall/ beam holes and cutting walls, etc. complete.

Providing & fixing PVC SWR TYPE B of 110 X 110 mm diameter with Height riser/ necessary 110MM Diameter of distance piece for urinal drain connection with floor clean out square cut 150mm- Satin of approved Make, making necessary slab/ wall/ beam holes and cutting walls, etc. complete.

Cleanout Plugs

Providing & fixing floor clean out square cut 150mm- Satin of approved Make with making necessary slab/ wall/ beam holes and cutting walls, etc. complete.

Pipe Sleeves

Pipe sleeves 50mm larger diameter than pipes shall be provided wherever pipes pass through walls and slabs and annular space filled with fireproof materials like putty, fire seal etc. All pipes shall be accurately cut to the required sizes in accordance with relevant BIS codes and burs removed before laying. Open ends of the pipe shall be closed as the pipe is installed to avoid entrance of foreign matters. Vertical sleeve shall finish 50mm above finish floor level.

4.0 TERRACE RAINWATER KHURRA, INLET MOUTH

Khurra

Khurras: 45x45cm with average minimum thickness of 5 cm, cement concrete 1:2:4 (1 cement:2 coarse sand :4 graded stone aggregate of 20mm nominal size) over P.V.C. sheet 1mx1mx400micron, finished with 12mm cement plaster 1:3 (1 cement: 3 coarse sand) and a QUOTE of neat cement rounding the edge sand making and finishing the outlet complete.

Inlet Mouth

Inlet mouth of rainwater pipe with cast iron grating 15cm diameter not less than 440gram.

5.0 DWC POLYETHYLENE PIPE

(Class SN 8 Structured Double Wall (Non-Smooth External Annular Corrugated wall & Smooth Internal wall) Polyethylene Piping System for non-pressure underground Sewerage & Drainage Applications)

Scope

This specification covers the requirements for manufacturing, supplying, transportation, handling, stacking of Class SN 8 Structured Double Wall (Non-Smooth External Annular Corrugated wall & Smooth Internal wall) Polyethylene Piping System for non-pressure underground Sewerage & Drainage Applications herein after called the DWC PE Piping System.

TECHNICAL SPECIFICATION

Applicable Codes

The manufacturing, testing at factory, supplying, transportation, handling, stacking, installation, jointing, and testing at sites shall comply with all currently applicable statutes, manuals, regulation, standards & codes. In particular, in addition to all relevant National Standards, following international standards with latest revisions shall be referred. If requirements of these specifications are at variance with any other standards, this particular document shall govern the proceedings.

EN 13476-1	Plastics piping Systems for non-pressure underground drainage and sewerage- Structured-wall piping systems of Polyethylene (PE) Part 1: General requirements and performance characteristics
EN 13476-3	Plastics piping Systems for non-pressure underground drainage and sewerage- Structured-wall piping systems of Polyethylene (PE) Part 3: Specifications for pipes and fittings with smooth internal and profiled external surface and the system, Type B

Other International Codes / Standards (EN/ ISO) which are integral part of above two standards as normative references form a significant portion of this specification document.

Manufacturing

The DWC PE Piping System of stiffness class designation SN 8 shall conform to the European Union standards as mentioned above and shall be configured as per the indicative Cross-sectional & Profile Drawings (Annexure A & B) annexed herewith. Each pipe shall be coupler (on-line or off-line) and spigot type along with rubber sealing ring (as designated under above international specifications).

Transportation

The arrangement of loading the pipes in a telescopic manner is advised, i.e. smaller diameters inserted into the next higher sizes of pipes. While loading the pipes onto the truck, care should be taken that the coupler- end should be arranged alternatively in the corresponding layers so as to avoid the damage to the coupling/ socket ends.

Handling

Following Recommendations shall be followed while handling the pipes:

- Adherence to National Safety requirements
- Pipes to be smoothly lowered to the ground
- Pipes should not be dragged against the ground to avoid the damages to the Coupler/pipes.
- 800mm and larger diameter pipes are carried with Slings at two points spaced approximately at 3 Meters apart
- For smaller diameters (400mm – 800mm) one lift point shall be sufficient & can be handled either manually or mechanically
- Do not use a loading Boom or Forklift directly on or inside pipe.

Pipe Storage at Site

TECHNICAL SPECIFICATION

- Stockpiling shall be done temporarily on a Flat Clear Area as per Fig. 1 & 2.
- For avoiding collapse of Stacks, use Wooden Posts or Blocks.
- Stacking shall not be higher than 2.5 Meters
- While stacking, alternate the socket/coupler ends at each row of stacked pipes as per Fig. 2.



(Fig 1)



(Fig 2)

Lowering, Laying & jointing of Pipes

The width of a Sewer Trench depends on the soil condition, type of side protection needed, and the working space required at the bottom of Trench for smooth installations. Increase in width over required minimum would unduly increase the load on pipe and cost of road restoration. Considering all above factors, the Minimum Trench Width is specified as per Table below: -

Indicative Trench Widths**	
Pipe Diameter (mm)	Trench Width (M)
75-170	0.6
250	0.7
400	0.9
600	1.2
800	1.3
1000	1.8

**In actual practice the trench width can be as narrow as possible but adequate to allow the workmen to execute the job satisfactorily.

The pipe segment between two manholes shall be laid approximately in straight line without any vertical undulations. However, on the strength of its flexibility, the DWC PE Piping system can be laid in very smooth curve if found necessary. The piping system shall rest on the carefully prepared bedding portion of the Backfill Envelope and at appropriate jointing locations the trenches shall be excavated deeper to accommodate the bulges of coupler-spigot joints. However, special care shall be ensured as mentioned below:

- Excavation of trenches shall be carried out in accordance with the drawing & specifications and as directed by the field engineer as well.
- The piping system shall be laid and jointed in true to gradient with the help of sight rails and boring rods as detailed in CPHEEO Manual on Sewerage and sewerage treatment. The levels need be checked with calibrated modern Levelling Instrument. Specific care shall be taken to prevent entry of sand / mud /slush/ any other foreign material etc into the system during the installation operation.

TECHNICAL SPECIFICATION

The structural property of the system suggests that a minimum cover of 300 mm adequate even for maximum quantum of superimposed (live) load.

In case of wider trenches than required (above table), the permission of the competent authority shall be necessary.

The bedding area is an essential portion of Back fill Envelope and shall be constructed with proper bedding material as computed in accordance with appropriate International code of practice for structural bedding design mentioned in the list of normative references under EN 13476. The bedding shall be laid to specified thickness and gradient with proper manual compaction of the aggregate.

The moulded on-line coupler (or separate coupler integrated to the pipe in case of lower sizes) will have a suitable internal surface for push-fitting the said end over the spigot end of the next pipe. On first valley of the corrugation of said spigot end (destined to receive the pushed coupler) the sealing rubber ring of standard (EN 13476) quality shall be placed so that the coupler end of the pipe smoothly but tightly slides over the sealing ring for making an absolute watertight joint. Similar system is also used for fabricated accessories or moulded fittings required such as Tee, Bends, Elbows, Reducer end caps for the purpose of installation of the system related to drainage/sewerage.

For quality connections following steps are to be ensured, failing which the performance aspects are to be severely compromised.

The non-coupler (socket) end needs to be thoroughly cleared and shall be free from any foreign material

- Clean and lubricate the coupler end of the pipe, if required.
- Lubricate the exposed Gasket in the same manner, if required.
- Keep the non-coupler end free from dirt, backfill material, and foreign matter so that the joint integrity is not compromised.
- Push the coupler into non-coupler and align properly. Always push coupler end into non-coupler end.

For smaller diameter pipes simple manual insertion shall be sufficient. It should be ensured that the coupler end is adequately 'homed' within non-coupler end to ensure installation and tight joining seal. Therefore prior to insertion always place a 'Homing Mark' on appropriate corrugation of the 'Non-Coupler End'.

Construction of backfill envelope and final backfilling of the trenches

DWC PE Piping System with well compacted Backfill Envelope along with the bottom and sides of trench (native soil) work together to support soil overburden and superimposed (traffic) loads. The carefully constructed Backfill Envelope has three distinct but non-isolated stages. The construction needs to be done stage by stage as per the sequence stated below:

- Bedding portion
- Up to Haunch level
- Remaining portion

The material for backfill envelope shall be in accordance with the structural design of flexible

TECHNICAL SPECIFICATION

buried conduit as per relevant international codes. It can be the same material that were removed in the course of excavation, or it can be fine sand/course sand/gravel / moorum /other form of course / fine aggregates depending on the effected Design Load [Overburden + Superimposed (Live) load]. However, in no circumstances, the flexible pipe should not be embedded in cement concrete (un- reinforced or reinforced) which invariably induces undesired rigidity in the system.

- The remaining portion of backfilling which do not contribute to the structural integrity of the system may be the materials that were removed in the course of excavation, or any other foreign material as may be required to suit the particular site condition. These materials shall consist of at least clean earth and shall be free from large clod or stone above 75 mm, ashes, refuse and other injurious materials.
- After completion of bedding portion of the Backfill envelop and subsequent lying of pipes, etc, first the haunch portion & then upper portion of Backfill Envelope shall be constructed as per design around the pipe. Voids must be eliminated by knifing under and around pipe or by some other indigenous tools.
- The compaction, by hand rammers or compactors with necessary watering to a possible maximum level of proctar density shall be ensured.
- Backfilling shall start only after ensuring the water tightness test of joints for the concerned sewer segments. However, partial filling may be done keeping the joints open.
- Precautions shall be taken against floatation (if at all necessary) as per the specified methodology and the minimum required cover.
- Continuity of the pipe segments in between two manholes is required to be ensured in the same modality as practiced for pipeline. Hydraulic testing of pipes shall be done, if specifically asked for by the client for any specific stretch.

Joining

- Elastomeric sealing ring joints/Solvent cement joint
- These pipes shall be socketed on automatic socketing machine with self-socket length. Such pipes shall be either joined with solvent cement or groove inside with rubber ring.

Continuity Test /Hydraulic Testing

- All lengths of the sewer and drain shall be fully tested for water tightness by means of water pressure maintained for not less than 30 minutes. Testing shall be carried out from manhole to manhole. All pipes shall be subjected to a test pressure of at least 1.5 mtrs. head of water. The test pressure shall, however, not exceed 6 metres head at any point. The pipes shall be plugged preferably with standard design plugs with rubber plugs on both sides. The upper end shall, however, be connected to a pipe for filling with water and getting the required head poured at one time permit.
- Sewer lines shall be tested for a straightness by:
 - Inserting a smooth ball 12 mm less than the internal diameter of the pipe. In the absence of obstruction such as yam or mortar projecting at the joints the ball should roll down the invert of the pipe and emerge at the lower end.
 - Means of a mirror at one end and a lamp at the other end. If the pipeline is straight the full circle of light will be seen otherwise obstructions or deviations will be apparent.

TECHNICAL SPECIFICATION

- The contractor shall give a smoke test to the drain and sewer at his own expense and charges, if directed by the Engineer in charge.
- A test register shall be maintained which shall be signed and dated by Engineer in charge.

Measurements

The mode of measurement shall be as per Schedule B.

6.0 INTERCEPTING TRAP

Providing and fixing intercepting trap of 150mm diameter in manholes with stiff mixture of cement mortar 1:1 (1 cement : 1 fine sand) including testing of joints etc

7.0 PERCOLATION WELL & TUBEWELL:

PURPOSE: to recharge by the way of drilling tube wells using storm water received through external surface.

REQUIREMENT:

- Geophysical (electrical resistivity) & hydrogeological, geology, hydrology survey and submit the report along with bore logging & electrical resistivity test.
- finding stratification of aquifer system and spatial variability of hydraulic conductivity of different zones.
- negative and nonproductive zones of low hydraulic conductivity.
- vertical hydraulic conductivity.
- moisture moment and infiltration.
- direction of ground water flow.
- salinity changes
- finalization of physical data
 - location of proposed structure
 - determination of number of structures
 - identification of tentative location.
- location identification- assessment of existing studies & recommendation
- geo tagging/google map -ne co-ordinates
- drilling pilot tube well to assess potentiality.

• DESIGN REQUIREMENT:

- Otests prior to commencement
- Oflow requirements/ rate of discharge/percolation
- Owater report- samples of water for analysis:
- Oinfiltration rates

TECHNICAL SPECIFICATION

- Oververticality of tube wells
- Ofilter pack
- Ocasing pipe

INCLUSION:

- drilling report
- infiltration record
- preliminary works for drilling, boring, access to specific areas
- water for all purposes
- power-dg or chargeable
- storage godown
- manpower colony arrangements outside site premises
- standard statutory obligation & responsibilities
- authority & departmental co-ordination
- post completion approval from cgwa
- amc-yearly & activities & schedule
- all rates are for site
- housekeeping & sealing & making good the area post completion of the works-handing over to client
- identification boards for each percolation wells
- as built drawings
- drilling & boring in all soil/rock as applicable using appropriate type of rig such as rotary, semi rotary and dth.
- safety & security during construction
- standard ohs & ehs requirements
- third part quality report/mtc
- all insurances other than car policy
- inclusion & exclusion list
- local issues if any

SPECIFICATION OF RECHARGE WELL

Construction of Percolation Well with all required connections as per detailed design and drawing with all required accessories. Scope shall include for Borewell depth up to 200m, with 3 m dia with 4m liquid depth+ invert Level with silting chamber(1.5m x 0.75m x 1.2m +IL) and overflow connection to the nearest drain. ITEM shall also including of precast/ RCC filtration module including of necessary filtration media for silt chamber and recharging pit.

DEVELOPMENT OF TUBE WELLS

SCOPE :

The scope includes construction of tube well to get required quantity of potable water with all material, testing, etc.

TECHNICAL SPECIFICATION

It is proposed to drill the tube well at the proposed in attached site plan or as per vendor based on resistivity survey or as per res in accordance with ISSR NO. 2800 - 1964 or latest.

The process to be adopted with direct rotary circulation method and tube well is to be installed as per the schedule where the actual length of housing pipe screen and blind pipe is to be worked out in accordance with the availability of strata. The annular space between the wall of hole and stainless-steel screen is to be packed with the suitable size of graded gravel to make the area immediately around the well bore for the flow of water to prevent sand from entering the well during pumping.

GENERAL :-

A.The purpose of constructing the tube well is to percolate ground water. The depth shall be according to the strata available as per site condition. It will have M. S. ERW housing pipes.

B.Below housing pipe, there shall be casing pipe having minimum thickness of 8 mm. Pipes shall be as per IS 1239 or 3589 /1991 and MS heavy duty strainer pipes for deep tube well shall be used.

METHODOLOGY / APPROACH

Process /methodology Involved in construction of wells up to 200m depth (or up to hard rock)

- A)site selection and pinpointing of site
- B)shifting of rig
- C)site preparation
- D)pilot hole drilling
- E)sample collection & preparation of lithology
- F)bore hole logging (resistivity/natural gamma)
- G)determining size of gravel packing
- H)preparation of composite log using data of (e) & (f) above
- I)designing of well assembly
- J)reaming of bore hole
- K)lowering of well assembly
- L)back washing, shrouding of gravel and clay packing (cement sealing, if required)
- M)measurement of yield using v notch/ volumetric method after encountering each fracture zone and simultaneous water sample collection and quality analysis for individual fracture zone
- N)verticality test of well
- O)development of well by air compressor/ pumping
- P)electrical logging/ caliper logging (need based)
- Q)percolation test

TECHNICAL SPECIFICATION

R)water sample collection for analysis of basic & heavy metals under guidance of site hydrogeologist/ chemist.

S)construction of platform, well capping and installation of protection box

T)preparation of basic data report & submission

U)handing over of well

DEFINITION:

In this contract a tube well will mean :-

A.satisfactory completion of bore hole drilling to the maximum prescribed depth in all type of strata, which shall include various kinds of water bearing strata including small boulder. The stated depths are approximate, and the contractor may have to go higher, or lower depth as decided by client as per condition of strata generally available in the site locality

The contractor shall have to arrange for electro logging and cost shall include the same .

B.the work includes installation of casing and housing pipes complete with strainer or slotted pipes including bail plug, reducer, clamp, top half coupling and well cap. The housing pipes, casing pipes, johnson strainer pipes, reducer, clamp wooden slippers well cap, half coupling and cone of bail plug shall have to be supplied by the contractor.

C.work includes placing of a gravel packing around casing housing and strainer pipes as per design. All gravel as per specification of required quality of (and) quantity will be supplied by contractor.

D.work Includes strata wise development of gravel packed tube well with adequate capacity air compressor.

E.the work includes development of gravel packed tube well with submersible pump with the object of obtaining a suitable quantity yield & shall nearly become sand free after 5 minutes of starting.

F.the scope also includes measuring of eccentricity and sound.

G.the scope shall also include well cap, ball plug, etc. Complete.

DRILLING PROCEDURE:

A.the contractor will employ direct rotary circulation method rig for the drilling of well. The design of the well for the discharge anticipated through will be of the firm. Yet the contractor is to continue drilling up to any depth when ordered by the engineer in charge (e.i.c.) in writing. The strata chart prepared on the basis of observation has to get approved from e.i.c. before arranging and installing the columns assembly through the responsibility for the design of the well will be that of the firm. If the e.i.c. feels that the sufficient water

TECHNICAL SPECIFICATION

bearing strata has not been obtained drilling will be stopped when directed by the e.i.c. in writing.

B.all water bearing strata decided by the e.i.c shall be tapped.

C.the contractor shall have to drill first a pilot bore and after completion of which the contractor shall have to inform e.i.c. for electro logging. Contractor shall have to arrange for electro logging of each bore. Without electro logging of bore, rimming work should not be started in any case.

D.after pipe and strainer lowering in the bore hole and before gravel packing, minimum hours back washing is required to keep proper mud density.

E.after gravel packing work, minimum hours back washing is required with clean water, putting washing line at the bottom.

F.the contractor shall have to use fresh quality of bentonite so that the mud salinity should be less than 230 ppm.

G.bore hole shall be drilled freely in plumb and vertical.

CONSTRUCTION OF TUBE WELL

A.DRILLING :

(A)after satisfactory drilling and bore hole rimming the contractor shall have to arrange lowering, installing and welding of housing pipes, casing pipes and strainer pipes including reducer, bail plug, joint covering strip, coupling, well cap etc. The contractor shall have to bring all the materials like bore pipes, reducers, strainer pipes, well cap, cone etc. Two days prior to lowering with necessary test certificates for approval of engineer in charge. The contractor shall have to obtain written permission from the engineer in charge only after these he can start lowering of the pipes in presence of client's engineer. The clamp shall be applied to the housing pipes supporting to the pipe 0.5 mt below the ground level and supported with wooden slippers. Before lowering housing and casing pipes it should be painted with black anticorrosive bituminous paint.

B.GRAVEL PACKING AS PER IS 4097-1967 OR LATEST :

(A)after the pipe assembly is lowered into position it is to be packed with suitable size of gravel to be designed on the basis of the analysis of character of water bearing formations in the first instance of gravel packing is to be done up to the bottoms of housing pipe. The verticality of the housing pipe is to be tested and defects if any to be rectified to assure that it is not out of vertical. Thereafter the position of housing the pipe is to be secured and the gravel packing up to the top to be completed. Feeding of the gravel is to be done in such a manner that there is no bridging in annular space. To avoid the bridging it would be helpful if the circulated fluid is pumped to agitate the gravel as it is being fed.

TECHNICAL SPECIFICATION

C. CASING

(i) m.s casing pipes/ slotted pipe as specified in above should confirm to the specification given below.

(ii) bis marked steel tubes plain ended for water wells of type erw conforming to table no.3 of is: 4270/2001 (third revision).

(iii) a length of 0.50 m of casing pipe should be left above the ground level.

(iv) m.s casing pipe should be installed perfectly vertical on the consolidated rock basement in such a manner that there should not be leakage of air during drilling. The annular space between the casing and the borehole wall should be grouted with cement slurry to avoid entry of local foreign material in the borehole in consolidated formations. The annular space above gravel pack may be filled with local clay in case of soft rock formation.

(v) well cap should be securely sealed to the pipe after bore hole is checked by the engineer-in charge. The well cap should be fabricated as per the provided specifications by client.

D. CONSTRUCTION OF PLATFORM, WELL CAP, PROTECTION BOX AND DISPLAY BOARD

After the completion of well in all respects described above, the contractor shall fabricate and install well cap using MS plate of minimum thickness 6mm, make platform around well, and install Display Board and Protection Box.

FOLLOWING TO BE IN BIDDER SCOPE-

- cement sealing by means of mud pump with cost of cement etc.
- mud pit
- mud lifting tanker

Note: bidder must follow latest cgwa notification for construction of tube well.

DEVELOPMENT OF TUBE WELL :

(A) the well shall be developed with the help of air compressor in first instance to assure proper slotting of the gravel and after each a strainer it properly dealt. The development is to continue with the help of reverse pumping set at a depression of 30ft. Or at a distance of 50% higher than the design discharge of the tube well which so ever is more including cost of water. The tube well is to be completely made sand free with no turbidity or at a most turbidity as defined in the ministry of health standards for drinking of water. After a contractor has reported that the development of tube well is completed. The tube well to be offered for testing observations are to be recorded in the shape of chart enclosed in the annexure in the manner prescribed in 155 – 2800 – 1964 or as per latest cgwa guideline.

TECHNICAL SPECIFICATION

(b) the water tanker for work of drilling and developing for the tube well will not be provided by client in any circumstances. The contractor has to arrange for water tanker at its own.

VERTICALITY TEST :

The tube well when out of alignment containing kinkers bend or core – screw is to be rejected straight way. The housing should be true to the line and the deviation from its top to the reducing socket in no case is more than 50 mm in the case when the housing pipe is 25 mtrs. Long and 75 mm when it is 30 mtrs. The deviation shall be in one direction and in one plan only. The deviation of the tube well is to be determined according to the method specified in ISS 2800 – 1964.

DATA COLLECTION

DRILLING CONTRACTOR WILL

(i) maintain a drill time log for every 3 m for wells drilled.

(ii) measure discharge over 90° v notch plate during drilling on every increase/ decrease of yield at various depths for wells drilled in hard rock formations.

(iii) collect formation samples of minimum 500 g mass at an interval of 3m or change of formation during drilling and properly pack in polythene bags and label with date/ depth/ location.

(iv) collect 1 liter water sample during the following stages:

A. For every water-bearing zone encountered for wells drilled.

B. After development is complete and during test for wells drilled

Necessary arrangements are to be made for verification by engineer-in-charge for checking of depth of borehole, length of casing, static water level, discharge and any other requirement as shall be felt necessary from time to time. A guest tent should be pitched at the site during drilling/ testing and provided with table and chairs for the engineer-in-charge.

SUCCESSFUL AND UNSUCCESSFUL WELL

Success of well will be decided by the Engineer-In-Charge. In case of non-availability of minimum thickness of aquifer capable of yielding expected discharge, the bore hole may be abandoned and payment based on actual work carried out will be made at quoted rates. The tube well abandonment committee will be constituted by concerned personnel from Client.

AQUIFER PERCOLATION TEST (APT)

TECHNICAL SPECIFICATION

The contractor has to carry out the apt in order to determine transmissivity, specific yield/ stativity in wells through reverse pumping/ tanker test method.

THE CONTRACT REPORT:

The contractor is required to furnish the following information:

A.he should recommend the suitability of site proposed by the client and in case of difference in opinion; he should suggest other site nearby for the required design of the tube well.

B.whether the test bore is proposed, and if yes its diameter and depth.

C.depth of tube well for shallow & deep well for availability of potable water respectively

D.method of drilling.

E.size and types of different strainer or slotted pipe etc.

F.probably yields of the water.

G.he should guarantee with regard to the verticality of the tube well and sand contents in the discharge at the time handling over the well.

FINAL TEST

The contractor shall give following certificates.

A.material test certificate and routine test certificate for m. S. Erw pipes as per Is 1239 or 3589/1981.

B.material test certificate and routine test certificate for johnson filtration make continuous slotted strainer pipes.

C.strata chart showing all the technical detail in triplicate as per the attached annexure.

D.compressor development report with details for all the strata in triplicate.

E.acceptance test certificate for clear sounding of tube well and site properly levelled and cleaned and cavity around the tube well duly packed with clay and certificate for well cap, bore pipe, clamp, wooden slipper, earthing terminal and half coupling on the top of the pipe.

F.after the tube well has been completed each joint of housing pipe, blind pipe and that of strainer will both screwed type and continue type welded with 2 nos. M.s. flats of size overlapping by 6" on either side by socket.

TECHNICAL SPECIFICATION

ANNEXURE -I

(STRATA TABLE)

NAME OF AGENCY :

LOCATION OF TUBE/BORE WELL :

STRATA CHART

DEPTH DRILLED

SIZE OF BORE

HOUSING PIPE

BLIND PIPE

STAINLESS STEEL SCREEN

SLOT SIZE

GRAVEL PACKING

BAIL PLUG

REDUCER

HOUSING CLAMP

CENTERING GUIDES

WELL CAP

TOTAL HOURS DEVELOPED

STATIC WATER LEVEL

YIELD

DRAWN DOWN

TECHNICAL SPECIFICATION

AQUIFER WATER LEVEL

REMARKS IF ANY.

ENGINEER – IN – CHARGE.

RATES ARE INCLUDING

Carrying out geological and hydrogeological investigation to understand the deposition pattern of geological layers and assess the groundwater potential and identify available lithology of the particular location/ point with probable formation material with depth / thickness of the layer along with approximate permeability and transmissivity of specific material to calculate water bearing capacity and rainwater recharge capacity by following methods.

(Geophysical Survey Involving Earth Resistivity Principles Vertical electrical sounding using Schlumberger 4 Electrode Array)

Carrying out geological and hydrogeological investigation to understand the deposition pattern of geological layers and assess the groundwater potential and identify available lithology of the particular location / point with probable formation material with depth / thickness of the layer along with approximate permeability and transmissivity of specific material to calculate water bearing capacity and rainwater recharge capacity by following methods.

(Geomagnetic Survey by using TESLA 6 ground water detector or similar equipment working on magnetotellurics 6 channel detection method)

Required Excavation for pits and trenches for Filtration chamber 2.5MX2.5mX3M in soil of required width, length and depth for the rainwater harvesting system in all types of soil, sand, gravel, clay, soft and hard Murom including removing all excavated material within the premises up to 100 meter lead, cleaning of site, removing shrubs, tree roots, vegetation and dewatering if required as per site condition, back filling, ramming, watering for depth up to 3.0 m as per the approved design/ drawing and specifications.

Providing and laying 150mm thick plain cement concrete 1:4:8 for base of the system using graded stone aggregate of 40 mm and below size including necessary formwork at various locations, including mixing, laying, consolidation, finishing, curing & dewatering the pits etc, all as per drawings, specifications and as directed.

Providing, fixing, testing and commissioning of readymade and light weight Polyethylene (PE) material rainwater harvesting system with HDPE ladder specially designed for underground application to absorb surrounding dynamic load having adequate water conveying capacity to function as primary surface filtration unit / secondary surface filtration unit having filter media up to 300 to 500 mm height in required shape/ size to achieve an effective sedimentation process connecting storm water drainage having as per manufacturer guidelines and approved design/ drawings with following specifications, 1000 mm dia x 1800 mm deep x 8 mm thick for Recharge well & Storm water reuse filtration

TECHNICAL SPECIFICATION

Providing, fixing and commissioning of readymade 600MM X 600MM Clear opening FRP recess manhole cover with frame adjustable to filtration chamber for the system specially designed with locking arrangement for various load bearing capacities for vehicular or nonvehicular movement suitable to application to be fixed to primary/ secondary filtration systems as per manufacturer guidelines and approved design/ drawings.

5 T load carrying capacity.

Providing, laying and fixing in position unplasticised rigid PVC pipes conforming to IS: 4985 (working pressure 6 kg/Sqcm) including all fittings such as bends, clamps to the specified invert levels and slope with provision of water meter fixing arrangement supported by sand filled bags, including all fittings such as NRV, bends, junctions, Tee, air vent, end-cap, flange adapters, in-situ adapter, access pieces/plugs jointing with uPVC adhesive including cutting holes and making it good water tight by using specially designed leak proof flange adapters joining, testing & commissioning of overall 10 meter pipe length for sub-surface filtration system as per design/ drawing as approved.

110 mm dia. For Recharge well

Supply, installation, testing and commissioning of smart water management system to collect real time water quantity parameters for conductive liquids like rainwater for underground application to be fixed in-line horizontal uPVC pipe having weather proof connection, with data logging device having IP68 housing with required isolated flow signal with paddle wheel flow sensor, microprocessor based transmission option for flow pattern recording with GSM / GPRS modem interface feature including 10 meter long cable for 12-24V DC power supply and 12V 3500mAh battery capacity, communicate all data to BMS, BMS Compatible including all necessary fixing arrangement as per design/ drawing as approved.

Flow meter

Supply, installation, testing and commissioning of smart water management system to collect real time water quantity parameters for conductive liquids like rainwater for underground application to be fixed in-line horizontal uPVC pipe having weather proof connection, with data logging device having IP68 housing with required isolated flow signal with paddle wheel flow sensor, microprocessor based transmission option for flow pattern recording with GSM / GPRS modem interface feature including 10 meter long cable for 12-24V DC power supply and 12V 3500mAh battery capacity, communicate all data to BMS, BMS Compatible including all necessary fixing arrangement as per design/ drawing as approved.

Centralized Monitoring along with third party API (Application Program Interface) Integration

Supplying and fixing two sets of four stage filtration arrangement on inlet and outlet pipes using suitable material to be fixed on uPVC pipe with SS clamp as per approved drawing/ design. For Sostrm water Recharge & Reuse Filtration system

Drilling and reaming bore hole at site using appropriate drilling methodology such rotary, semi rotary, DTH as suitable to site geology up to designed depth by bentonite or mud flushing of the borehole including supplying, loading, unloading and filling of sticky clay balls of size 25mm to 50mm and gravel packing in surrounding gaps while developing of each water bearing zones by using required capacity of air compressor including required machineries, equipment's, safety measures as per approved design/ drawing and direction of site engineer.

TECHNICAL SPECIFICATION

Rate inclusive of creating pit for drilling process, if required and removal of mud by mud tankers or any other way suitable to site condition, obtain bore-log report from govt. authorized agencies
450 mm dia bore hole

Providing, laying and fixing in position solid uPVC Casing pipe having minimum 6 kg/ sqcm pressure rating including all leakproof fittings jointing with uPVC adhesive including joining, testing & commissioning as per approved design/ drawing.
160 mm dia with solid CM grade casing pipes.

Providing, laying and fixing in position solid uPVC Casing pipe having minimum 6 kg/ sqcm pressure rating including all leakproof fittings jointing with uPVC adhesive including joining, testing & commissioning as per approved design/ drawing.
160 mm dia with perforated CM grade casing pipes.

8.0 CHLORINATED POLYVINYL CHLORIDE (CPVC) PIPES

CPVC pipes & fittings used in hot & cold potable water distribution system shall conform to requirement of IS 15778. The material from which the pipe is produced shall consist of chlorinated polyvinyl chlorides. The polymer from which the pipe compounds are to be manufactured shall have chlorine content not less than 66.5%.

The internal and external surfaces of the pipe shall be smooth, clean and free from grooving and other defects. The pipes shall not have any detrimental effect on the composition of the water flowing through it.

Notes

For CPVC pipes SDR is calculated by dividing the average outer diameter of the pipe in mm by the minimum wall thickness in mm. If the wall thickness calculated by this formula is less than 1.52 mm, it shall be increased to 1.52 mm. The SDR values shall be rounded to the nearest 0.5.

Dimensions of Pipes

The outside diameter, outside diameter at any point and wall thickness shall be as given in Table 18.16.

Diameter

The outside diameter and outside diameter at any point as given in Table 18.16 shall be measured according to the method given in IS 12235 (part 1).

Diameter at any point

The difference between the measured maximum outside diameter and measured minimum outside diameter in the same cross-section of pipe (also called tolerance on ovality) shall not exceed the greater of the following two values

- (a) 0.5 mm, and
- (b) 0.012 dn rounded off to the next higher 0.1 mm.

TECHNICAL SPECIFICATION

Wall Thickness

The wall thickness of the pipes shall be as given in Table 18.16. Wall thickness shall be measured by any of the three methods given in IS 12235 (part 1). To check the conformity of the wall thickness of the pipe throughout its entire length, it is necessary to measure the wall thickness of the pipe at any point along its length. This shall be done by cutting the pipe at any point along its length and measuring the wall thickness as above. Alternatively, to avoid destruction of the pipe, nondestructive testing methods such as the use of ultrasonic wall thickness measurement gauges shall be used at any four points along the length of the pipe.

Tolerance on Wall Thickness

- (a) For pipes of minimum wall thickness 6 mm or less, the permissible variation between the minimum wall thickness (e_{Min}) and the wall thickness at any point (e), ($e - e_{Min}$) shall be positive in the form of $+y$, where $y=0.1 e_{Min}+0.2$ mm.
- (b) For pipes of minimum wall thickness greater than 6mm, the permissible variation of wall thickness shall again be positive in the form of $+y$, where y would be applied in two parts.
- (c) The average wall thickness shall be determined by taking at least six measurements of wall thickness round the pipe and including both the absolute minimum and absolute maximum measured values.
The tolerance applied to this average wall thickness from these measurements shall be within the range $0.1 e_{Min}+0.2$ mm (see Table 18.16).
- (d) The maximum wall thickness at any point shall be within the range $0.15e_{Min}$ (see Table 18.16).
- (e) The results of these calculations for checking tolerance shall be rounded off to the next higher 0.1 mm.

Effective Length (L_e)

If the length of a pipe is specified, the effective length shall not be less than that specified. The preferred effective length of pipes shall be 3, 5 or 6 m. The pipes may be supplied in other lengths where so agreed upon between the manufacturer and the purchaser.

Pipe Ends

The ends of the pipes meant for solvent cementing shall be cleanly cut and shall be reasonably square to the axis of the pipe or may be chamfered at the plain end.

Physical and Chemical Characteristics

Visual Appearance: The colour of the pipes shall be off-white. Slight variations in the appearance of the colour are permitted. The internal and external surface of the pipe shall be smooth, clean and free from grooving and other defects.

TECHNICAL SPECIFICATION

Opacity: The wall of the plain pipe shall not transmit more than 0.1 per cent of the visible light falling on it when tested in accordance with IS 12235 (Part 3).

Effect on Water: The pipes shall not have any determinate effect on the composition of the water flowing through them, when tested as per 10.3 of IS 4985.

Reversion Test: When tested by the method prescribed in IS 12235 (Part 5/ Sec 1 and Sec 2), a length of pipe 200 ±20 mm long shall not alter in length by more than 5 per cent.

Vicat Softening Temperature: When tested by the method prescribed in IS 12235 (part 2), the Vicat softening temperature of the specimen shall not be less than 110°C.

Density: When tested in accordance with IS 12235 (Part 14), the density of the pipes shall be between 1450kg/m³ and 1650kg/m³.

Mechanical Properties

Hydrostatic Characteristics: When subject to internal hydrostatic pressure test in accordance with the procedure given in IS 12235 (part 8/Sec 1), the pipe shall not fail during the prescribed test duration. The temperatures, duration and hydrostatic (hoop) stress for the test shall conform to the requirements given in Table 18.17. The test shall be carried out not earlier than 24 h after the pipes have been manufactured.

TABLE 18.17
Requirements of Pipes for Internal Hydrostatic Pressure Test
(Clause 18.9.5.1)

Sl. No.	Test	Test Temperature Min	Test Period	Hydrostatic (Hoop) Stress
		°C	h	MPa
(1)	(2)	(3)	(4)	(5)
(i)	Acceptance	20	1	43.0
(ii)	Type	95	165	5.6
(iii)	Type	95	1000	4.6
(iv)	Type	95	8760	3.6 (Test for thermal stability)

Thermal Stability by Hydrostatic Pressure Testing: When subject to internal hydrostatic pressure test in accordance with the procedure given in IS 12235 (Part 8/Sec 1) and as per requirement given in Table 18.17, Sl. No. (iv), the pipe shall not burst or leak during the prescribed test duration.

Resistance to External Blow at 0°C: When tested by the method prescribed in IS 4985, with classified striker mass and drop height as given in Table 18.18, the pipe shall have a true impact rate of not more than 10 per cent.

TABLE 18.18
Classified Striker Mass and Drop Height Conditions for the Falling Weight Impact Test
(Clause 18.9.5.3)

TECHNICAL SPECIFICATION

Sl. No.	Nominal Pipe Size	Mass of Falling Weight	Falling Height
	mm	Kg	mm
(1)	(2)	(3)	(4)
(i)	15	0.5±0.5%	300±10
(ii)	20	0.5±0.5%	400±10
(iii)	25	0.5±0.5%	500±10
(iv)	32	0.5±0.5%	600±10
(v)	40	0.5±0.5%	800±10
(vi)	50	0.5±0.5%	1000±10
(vii)	65	0.8±0.5%	1000±10
(viii)	80	0.8±0.5%	1200±10
(ix)	100	1.0±0.5%	1600±10
(x)	150	1.6±0.5%	2000±10

Flattening Test: When tested by the method prescribed in IS 12235 (part 19), pipe shall show no signs of cracking, splitting and breaking.

Tensile Strength: When tested by the method prescribed in IS 12235 (Part 19), the tensile strength at yield shall not be less than 50 MPa at $27 \pm 2^\circ\text{C}$.

Sampling and Criteria for Conformity

The sampling procedure and criteria for conformity shall be as given in Annexure F.

Marking

Each pipe shall be clearly and indelibly marked in ink/paint or hot embossed on white base at intervals of not more than 3 m. The marking shall show the following:

- Manufacturer's name or trademark.
- Outside diameter,
- Class of pipe and pressure rating, and
- Batch or lot number

BIS Certification Marking: Each pipe may also be marked with the Standard Mark.

Fittings

The fittings shall be as follows:

- Plain CPVC solvent cement fittings from size 15 mm to 160 mm.
- Brass threaded fittings.
- Valve from size 15 mm to 160 mm
- Brass Threaded Fittings: All types of one end brass threaded male/female adaptors in various fittings like coupler, socket, elbow, tee is available for transition to other plastic/metal piping and for fixing of CP fittings. Ball Gate valves in CPVC are available in all dimensions. All fittings shall carry the following information:
 - Manufacturer's name/trademark.
 - Size of fitting

Piping Installation Support and Spacing

TECHNICAL SPECIFICATION

Concealed Piping

Pipes can be concealed in chases. The pipes and fitting are to be pressure tested prior to concealing the chases. To maintain alignment of CP fittings while joining, all alignment of fittings and pipe shall be done correctly. DO NOT USE NAILS FOR HOLDING OF PIPES IN THE CHASES.

External Installations

For pipes fixed in the shafts, ducts etc. there should be sufficient space to work on the pipes. Pipes sleeves shall be fixed at a place the pipe is passing through a wall or floor so as to allow freedom for expansion and contraction. Clamping of the pipe is done to support it while allowing the freedom for movement.

All pipes exposed to sunlight shall be painted with a water based acrylic paint emulsion to enhance UV protection. Pipes in trenching shall be laid in accordance to the Good Plumbing practices followed for Metal piping.

Recommended Support Spacing (Distance between Pipe Clamps Horizontal Support)

Pipe Size	Horizontal Support (In meters)			
	Temperature			
	23°C	38°C	60°C	82°C
16 mm (1/2")	1.22	1.22	1.07	0.92
20 mm (3/4")	1.53	1.37	1.22	0.92
25 mm (1/0")	1.68	1.3	1.37	0.92
32 mm (1 1/4")	1.83	1.68	1.53	1.22
40 mm (1 1/2")	1.98	1.83	1.68	1.22
50 mm (2")	2.29	2.14	1.98	1.22

Expansion LOOP

CPVC systems, like all piping materials, expand and contract with changes in temperatures. CPVC pipes shall expand 7.5 cm per 30 m length for a 40°C temperature change. Expansion does not vary with Pipe size. Thermal expansion can generally be accommodated at changes in direction. On a long straight run, an offset or loop based on the following chart is required.

Nominal Pipe Size	Length of Run (Meter), Loop length in cms.				
	6 metre	12 metre	18 metre	24 metre	30 metre
15 mm	43	56	69	79	86
20 mm	48	66	81	91	104
25 mm	53	74	91	104	117
32 mm	58	81	102	117	130
40 mm	63	89	109	127	142
50 mm	71	102	124	145	163

Testing

All water supply systems shall be tested to hydrostatic pressure test. The pressure tests are similar to the test pressure used for other plastic/metal pipes. System may be tested in

TECHNICAL SPECIFICATION

sections and such section shall be entirely checked on completion of connection to the overhead tank or pumping system or mains.

Measurements

The net length of pipes as laid or fixed shall be measured in running meters correct to a cm for the finished work, which shall include CPVC pipe and fittings including plain and Brass threaded fittings and jointing solvent cement.

9.0 PLUMBING INSULATION FOR HOT WATER SUPPLY

Scope:

The scope of this section comprises the supply and fixing of insulation conforming to these specifications and in accordance with requirement of Bill of quantities.

MATERIAL: Closed Cell EPDM Rubber

Thermal insulation material for Pipe Insulation shall be closed cell Elastomeric EPDM Rubber. The Thermal conductivity of the insulation material shall not exceed 0.038 W/m^oK at an average temperature of 32^oC. Density of the EPDM rubber shall be 40-60 Kg/m³. The product shall have temperature range of -57 ^oC to 125^oC. The insulation material shall be fire rated for Class V 0 as per UL 94. The flammability and smoke density shall be 25/50 as per ASTM E 84. Non flammable as per JIS K 6911, Australian standard 1530 and class 5.3 as per EMPA. Water vapour diffusion resistance factor(μ) \geq 7000. The water absorption (weight%) shall not exceed 5 as per ASTM D 1056. The insulation material should be free from Nitrosamine contents as per US FDA norms. It should be CFC free. It should not be corrosive to copper and stainless when tested as per DIN 1988. The material should not develop crack when tested for ozone resistance as per ASTM 1149. The % shrinkage (Heat Stability) should not exceed 6 when tested as per ASTM C 534(93^oC, 7 days). No cracks should develop when exposed to UV (accelerated weathering resistance test cycle UVB-313 at 60 ^oC/8h, CON at 50 ^oC/4h) as per ASTM G 154-04. The resistance to microbiological growth should be in accordance to UL 181 – and meet the acceptance criteria of resistance to fungal contamination as per ASTM G21. It should meet the acceptance criteria of resistance to bacterial contamination as per ASTM 2180.

Thickness of the insulation shall be as specified for the individual application. Each lot of insulation material delivered at site shall be accompanied with manufacturer's test certificate for thermal conductivity values, density, water vapour resistance factor, Nitrosamine content, Heat stability and fire properties. Samples of insulation material from each lot delivered at site may be selected by Owner's site representative and gotten tested for thermal conductivity and density at Contractor's cost. Adhesive used for sealing the insulation shall be modified neoprene contact adhesive with minimum bond strength of 1.25 kg/m². It should have high water vapour resistance, good weathering properties and self-extinguishing once dried strictly as per manufacturer's recommendations.

1.1 HOT WATER SUPPLY & RETURN PIPING INSULATION

Insulation Material Technical Specification – Anti-bacterial and anti-fungal Closed Cell Elastomeric Foam made from EPDM rubber with self-bonded olefin (HDPE) covering

Material: EPDM

TECHNICAL SPECIFICATION

Density: 40-60 kg/m³

Thickness: 25 mm

A. Closed Cell EPDM Rubber

- Thermal conductivity of elastomeric foam shall not exceed 0.035 W/ (m*K) at an average mean temperature of 24o C (Tested acc. To ASTM C177)
- Material shall be anti-fungal and shall pass resistance to Fungi test in accordance with UL181.
- Material shall be anti-Bacterial and shall pass bacterial resistance test in accordance with ASTM E2180-01.
- Material shall have fire class A (Flame spread: 20 & Smoke developed index 150) in accordance with ASTM E 84.
- It shall have rate of burning (horizontal position) test in accordance with part-2 ASTM D635-06.
- Material shall have flammability class V-0 in accordance to UL94.
- Material shall be non-corrosive for copper and stainless steel in accordance with DIN 1988.
- The material is Dust and Fibre Free
- Unlike other generic materials it shall be self-extinguishing, does not drip fireballs and does not spread flames
- It shall have Moisture Diffusion Resistance Factor or 'μ' value minimum 7,000 per EN 12086 without any outer facing
- Material shall be CFC/HCFC free and tested in accordance with USEPA 5021A/USEPA8260C
- Density of material shall be 40-60 kg/m³ in accordance to ASTM-D-1667.
- Material shall have service temperature range -50°C to +125°C.
- Material Color: Black

B. Self-bonded polyethylene Fibre Cloth

- High density polyethylene fibre cloth bonded with moisture control metal foil films attached with high strength self-adhesive with silicone releasing paper.

Material : High Density Poly olefin Fibre Cloth

Thickness : 0.2mm

- It shall have good UV protection and water repellent property which enhances system life.
- The opacity of product shall be 0.16% as per ASTM D1746.
- It shall have 4.23 mg/cm² water vapour permeability as per IS 101: part 6.

C. Fibre Glass Cloth

- Material is acrylic based woven fiberglass fabric made from E glass having excellent combination properties of high strength & moisture resistance.

Material : Fibre Glass Cloth

TECHNICAL SPECIFICATION

Thickness : 0.19mm

- It shall acrylic PSA type adhesive.
- It shall have E glass type fiber.
- Base fabric mass shall be $225 \pm 5\%$ GSM
- Total mass shall be $280 \pm 5\%$ GSM

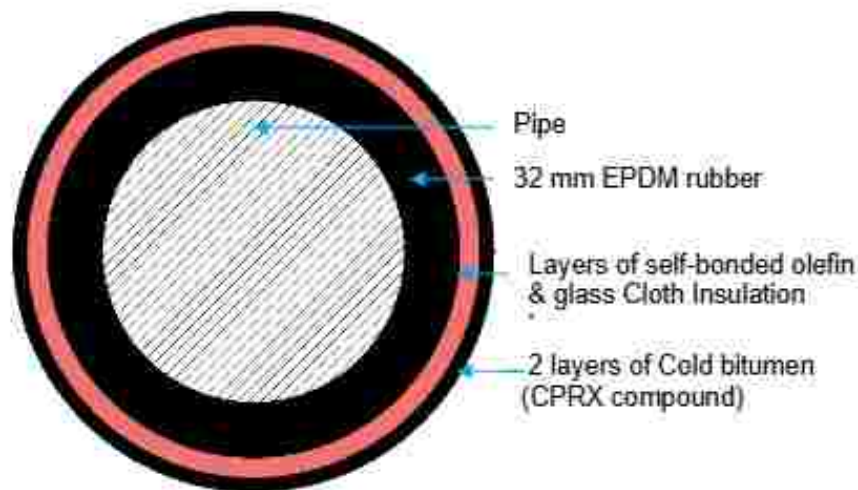

Specifications Self bonded olefin (HDPE) for Outer covering of Insulation Material

- It is HDPE fiber cloth bonded with moisture control metal foil film.
 - It has good UV resistance and water resistance property.
- It has high water vapour diffusion resistance and low thermal conductivity

1.2 Method of Measurement for Insulation:

Unless otherwise specified measurement for pipe insulation for the project shall be on the basis of centre line measurements described herewith

- a. Pipe Insulation shall be measured in units of length along the centre line of the installed pipe, strictly on the same basis as the piping measurements described earlier. The linear measurements shall be taken before the application of the insulation. It may be noted that for piping measurement, all valves, orifice plates and strainers are not separately measurable by their number and size. It is to be clearly understood that for the insulation measurements, all these accessories including cladding, valves, orifice plates and strainers shall be considered strictly by linear measurements along the centre line of pipes and no special rate shall be applicable for insulation of any accessories, fixtures or fittings whatsoever.

10.0 SWR - UPVC PIPES & FITTINGS

Soil, waste, vent SWR Ring Fit/Solvent pipes with socket and spigot. All pipes shall be straight and smooth and inside free from irregular bore, blow holes, cracks and other manufacturing defects. These pipes conform to EN 1329 / IS 13592 (SWR type B) and are designed to withstand continuous internal hydraulic pressure of 6 Kg/cm so as

TECHNICAL SPECIFICATION

to ensure life-long trouble-free working. The pipes are provided with an integral rubber ring type socket at one end while the other end is kept plain, smooth and free from burrs. Rubber ring type socket ends provide easy push – fit type jointing. Simultaneously, allowance for thermal expansion can also be provided during installation.

Fittings:

Fittings shall conform to the corresponding Indian Standard as for pipes. Contractor shall use pipes and fittings of matching specification/manufacturer standard.

Access door shall be secured air and watertight with 3mm thick insertion rubber washer and white lead. The bolts shall be lubricated with grease or white lead for easy removal.

Fittings shall be of the same make as that of pipes, injection moulded and shall conform to Indian Standard.

Jointing:

The jointing of the pipes to the fittings shall be done as per the manufacturer's instructions / recommendation. The rubber ring socket fittings and pipes shall be jointed as follows:-

Clean the outside of the pipes spigot end and the inside of the ceiling groove of the fitting.

Apply the lubricant uniformly to the spigot end, sealing ring and pass the spigot end into the socket containing sealing ring until fully home. Mark the position of the socket edge with pencil or felt open on the pipe, then withdraw the pipe from the socket by approximately 10 mm to make the pipe fully fitted to the fitting. The horizontal pipes on the wall shall be fixed with M.S. fabricated clamps with necessary provisions to take care the expansion and contraction in PVC pipes.

Rubber Seal Rings for Joints & Access Doors : Manufactured in accordance with IS : 5382 for 75 mm / 90 mm / 110 mm sizes. These are made out of natural rubber with a shore 'A' hardness of 40 × 5. Provide superior resistance to biological attack. Special design of cross section ensures perfect sealing.

Lubricant: Available in 100 gms, 250 gms & 500 gms packing. Specially formulated for compatibility with rubber seal as well as PVC. Does not support the growth of bacteria or fungi.

Pipe, Hangers, Support, Clamp, Bracket etc.:

Supports:

The spacing of the clamps shall be at the intervals of 1.5 mtr to 2 meter depends on the requirement of the supporting arrangements.

Pipes shall be aligned properly before fixing them on the wooden plugs with clamps. Even if the wooden plugs are fixed using a plumb line, pipe shall also be checked for its alignment before clamping, piping shall be properly supported on, or

TECHNICAL SPECIFICATION

suspended from clamps, hangers as specified and as required. The Contractor shall adequately design all the brackets, saddles, anchors, clamps and hangers and be responsible for their structural sufficiency. Pipe supports shall be primer coated with rust preventive paint.

Testing:

Before the system is put into use, it should be tested for leakages by air test, hydraulic test or smoke test.

11.0 BALL VALVES (FLOAT VALVE):

The ball valve shall be of high-pressure class and shall be confirm to IS: 1703 of sizes as specified. The nominal size of a ball valve shall be that corresponding to the size of the pipe to which it is fixed. The ball shall be of brass or gun metal as specified and the float shall be of polythene sheet. The minimum gauge of copper sheet used for making the float shall be 0.45mm for float up to 115mm dia and 0.55mm for float exceeding 115mm dia and shall be special in shape. The valve shall be constructed to permit replacing without console of the valve body from the valve line and the system shall not blow out under pressure. The jointing of the float shall be made by efficiently burnished, lapped and soldered seam or by bracing. Plastic float may also be used if specified. The body of ball valve when assembled in working conditions with the float immersed to not more than half of its volume shall remain closed against a test pressure of 10.5 Kg/Sq.cm. All ball valves shall be capable of withstanding a pressure of 14 Kg/Sq.cm.

The ball valve shall generally conform to IS specifications NO. 1703-2000

Providing and fixing float valve with pressure type PTMT float valve.

12.0 BUTTERFLY VALVES

- Butterfly valves as per IS - 13095 / 1991
- SCOPE - Fabricated valve will not be considered.
- This standard cover double flanged and wafer type of metal seated, resilient seated cast iron, ductile iron, and carbon steel and lined butterfly valves for general purpose. Valves covered under this standard are manually, pneumatically, hydraulically or electrically operated.
- It covers valves of nominal pressure designations up to and including 4 MPa, and class 300 with ends flanged in accordance with appropriate table of IS 6418: 1971 'Cast iron and malleable cast iron flanges for general engineering purpose' or wafer type valves with bodies designed to be accommodate between pipe work flanges in accordance with appropriate table of IS 6418 : 1971 or IS 6392 : 1971 'steel pipe flanges' in nominal size DN 40 to DN 2000. It also covers valves up to class 300 and flanges as per the pressure/temperature ratings given in IS 13159 (Part 1) : 1991 'steel

TECHNICAL SPECIFICATION

pipe flanges and flanged fittings : part I dimensions' and IS 6418 : 1971 'cast iron and malleable cast iron flanges for general engineering purposes.

- **REFERENCE**

- The applicable Indian standards are necessary adjuncts to this standard.

- **TERMINOLOGY AND DEFINITIONS**

- Terminology and definition covered in IS 4854 (Part3) : 1974 are generally applicable.

- **VALVE END CONNECTIONS**

- Double flanged valves

- A valve having flanged ends for connection to pipe flanges by individual bolting.

- Water valve

- A valve for clamping between two pipe flanges using through bolting this may be single flange, lug type, U- section or flangeless type.

- **SERVICE APPLICATIONS**

- Valves shall be suitable for one or more of the following applications.
- Tight shut off - A valve having no visible leakage past the disc in closed position under test conditions.
- Regulating - A valve intended for regulating purpose and which may have a clearance between the disc and the body in close position.
- Low leakage - A valve which has specified maximum leakage rate past the disc in the closed position.

- **VACUUM CONDITION**

- Where valve are to be used under vacuum conditions, purchaser shall mention specifically and the detailed design provision shall be mutually agreed between the purchaser and the manufacturer.

- **NOMINAL SIZES**

- The range of nominal valve size (DN) in mm shall be as follows:
- 40,50,65,80,100,150,200,250,300,350,400,450,500,600,700,800,900,1000,1200,1400,1600,1800 and 2000

- **NOMINAL PRESSURES**

- Valve shall be designated by nominal pressure (PN) defined as the maximum permissible working pressure (Mpa) at 20 0 C temperatures as follows:
- PN 0.25, PN0.6, PN1.0, PN1.25 and PN4.0.
- The class designation for valves specified by nominal pipe size shall be class 125, class 150 and class 300.

- **PRESSURE/TEMPERATURE RATINGS**

- Maximum permissible gauge working pressure and operating temperatures shall be in accordance with IS 6418 : 1971 and IS 13159 (Part I) : 1991 except that restriction on temperature may be placed by the manufacturer on valves in accordance with this standard by reason of valve type, trim materials or other

TECHNICAL SPECIFICATION

factors. However, all valves shall be suitable for continuous use at their PN designation within the temperature range of -10° c to 65° c.

• BODY ENDS

- o Double Flanged Body Ends
- The dimensions of flanged body ends and drillings shall be in accordance with the requirement given in Annex B. Flanges as per any other specific requirements of the purchaser may also be given as agreed to between the manufacturer and the purchaser or as per I.S. 13159 (part I) : 1991.
- Flanges shall be at right angles to the axis of the bore and concentric with the bore.
 - o Flanges shall be drilled unless otherwise specified and bolt holes shall be off centers. Tapped by the design of the valve.
 - o Wafer Body Ends
- Body ends shall be capable of being fitted between the pipe flanges complying with the requirements of annex B flange drilling.
- The joint faces shall be at right angles to the axis of the bore and concentric with the bore.
 - o Holes may be provided, where required by the design, for the passage of the bolts securing the flanges and the valve. Where through bolting is not practicable due to the presence of valve shaft, bearing housing, tapped holes may be provided for individual bolting of each flange.

• FACE TO FACE DIMENSIONS

- o Face to face dimensions of double flanged and wafer types of valve shall be as per Table 1.
- o Face to face dimensions given in Table 1 are exclusive of the sealing gaskets at both ends.
- o The manufacturer shall ensure that adequate space will be available between valve flanges for bolting when flanged valve with short body face to face to face or wafer long face to face are manufactured.
- o Tolerance on face to face dimension in Table 1 shall be as follow.

e

Face to face dimension of Unlined valve MM		Tolerance MM
Over	Up to and including	
0	250	+2
250	500	+3
500	800	+4
800	100	+5
1000	2400	+6

• BODIES

TECHNICAL SPECIFICATION

- Bodies end ports shall be circular and the numerical values of the diameter shall be as close as possible to the valve of DN.
- **DISC AND SHAFT**
 - The disc and shaft shall be designed to withstand the maximum pressure differential across the valve in either direction of flow. The shaft may be of one piece design or in two pieces separately attached to the disc. Any means of attachment between the shaft and the disc shall be such as to preclude components becoming loose in service.
- **SEATING AND LININGS**
 - Non-integral seating, and lining where used, and their means of attachment shall be such as to preclude their becoming loose in service.
- **BEARINGS**
 - The bearings shall be suitable for the maximum loads imposed by the shaft during testing and in service.
 - For valves DN 350 and above, a bearing shall be provided to take the axial thrust, spring retaining clips (cir clips) shall not be used as thrust bearing.
 - Suitable sealing shall be provided for the shaft where it passes outside the pressure containing enclosure.
- **MATERIALS**
 - This standard is based on materials specified in Table 2. Unless otherwise agreed, the materials shall be of a grade equivalent to those given in Table 2 or superior. Other material may be used as per agreement between the manufacturer and the purchaser.
- **OPERATION**
 - Manual Operation
- All valves shall be capable of operated at a differential pressure across the disc as marked on the valve. Lever, worms gear/traveling nut type or any other suitable type of operator can be used.
 - Direction
- Unless otherwise specified manually operated valves shall be closed by turning hand wheel or lever in a clockwise direction when facing the hand wheel or lever. The design of lever when fitted shall be such that the lever may only be assembled to the valve so that it is parallel to the direction of flow when the valve is open.
- All gear traveling nut operators shall be provided with suitable stops to prevent movement of the shaft beyond the limit corresponding to the fully closed position of the disc.
- All gear traveling nut operators shall be packed with grease for life time operation. Gear/traveling nut operators shall be totally enclosed and weather proof for general application. For special applications such as marine, submerged service etc. The purchaser may specify special enclosure.

TECHNICAL SPECIFICATION

- All gear/traveling nut operators shall be self locking type. All lever operated valve shall be capable of being locked at least three intermediate position.
- The operating hand-wheels shall be marked 'CLOSE' or 'SHUT' to indicate the direction of closer.
- The operator shall be provided with arrangement to indicate the disc position.
- **TESTING**
 - All valves shall hydrostatically tested by the manufacturer before dispatch. The pressure shall be obtained without any significant hydraulic shock. Testing shall be carried on before application of paint or other similar treatment unless otherwise agreed between the purchaser and the manufacturer. There shall be no air entrapped within the part of the valves subjected to test pressure.
- **PERFORMANCE TESTING**
 - Each valve shall be shop operated from fully closed to fully open position and reverse, under no pressure and no flow condition to demonstrate that the complete assembly is workable.
- **BODY TEST**
 - Completely assembled valve shall be tested as follows:
 - 'The body ends shall be blanked so that the valve is subjected to the full pressure in all directions include by the test pressure water valves may be tested in any suitable manner agreed between the purchaser and the manufacturer. The valve disc shall be in slightly open position and pressure equivalent to 1.5 times the maximum permissible working pressure shall be applied with water. The duration of this test shall be as in Table 3.'
- **SEAT TEST**
 - The seating surface of the valve shall be cleaned unless a surface treatment forms an integral part of the design or the use of a temporary surface treatment has been agreed between the manufacturer and the purchaser to avoid the possibility of damage under the condition of the test.

TABLE-3

Nominal DIA MM	Minimum test duration in minutes	
	Body Test	Seat test when applicable
Up to and including 50	0.25	0.25
65 to 150	1.0	1.0
200 to 300	2.0	2.0
350 to 1000	5.0	2.0
1200 to 2000	5.0	3.0

- Each valve shall be shop tested for leaks in close position. The test shall be conducted with the body flanges in a horizontal position. Pressure shall be applied to the upstream end of the valve, the downstream being open to atmosphere. The duration of test shall be as per Table 3. There shall be no indication of leakage past the valve disc during test and valves shall be drop tight. Seat test shall be carried out in both the direction of valve if agreed between the manufacturer and the purchaser. The seat pressure applied on

TECHNICAL SPECIFICATION

upstream side shall be equivalent to 1.1 times the maximum permissible working pressure at 20° c and shall be applied with water.

- o For regulating type valves seat test shall not be applicable.

• DISC STRENGTH TEST

- o The test shall be conducted with the body flanges in horizontal position. The test pressure shall be 1.5 times the maximum permissible pressure at 20.0 C With disc in closed position, hydro test pressure shall be applied to the lower face of the disc for duration as per table-3. There shall be no damage to the valve disc nor shall any part of valve or disc be permanently deformed by the test. The purpose of this test is to provide evidence of the adequacy and structural integrity of disc and body. Any leakage past the seat shall not be the criteria for rejection of the valve (Sampling test sample as per IS 2500). For regulating type valves, disc strength shall not be applicable.
- o Maximum permissible leakage shall be as per table 4.

• TEST CERTIFICATES

- o When specified by the purchaser, the manufacturer shall issue a test certificate conforming that the valves have been tested in accordance with this standard and stating the actual pressures and medium used in the test.

VALVE TYPE	LEAKAGE RATE
Tight shut-off	No visible leakage for duration of test
Low leakage	0.1 mm ² /s X DN (sec 5)
Regulating	Not specified. Outside the scope of this standard.

• INSPECTION

- o If inspection is required, this shall be stated in the enquiry/order. The purchaser or his authorized representative shall have access to the manufacturer's works at all reasonable times to inspect assembled valve to his order.

• WITNESSING OF TESTS

- o When the purchaser desires to witness the tests, this shall be specifically agreed in advance.

• MARKING

- o Marking shall be cast integral on the body or on a plate securely attached to the body. The markings shall be in accordance with I.S. 9866: 1981.

• PREPARATION FOR DESPATCH

- o Valve shall be complete in all respect when shipped. Each valve shall be drained, cleaned, prepared and suitably protected with 2 coats of red oxide on un machined surfaces and rust preventive coats on machined and flanged surfaces for dispatch in such a way as to minimize the possibility of damage and deterioration during transit and storage. Painting other than specified on the

TECHNICAL SPECIFICATION

finished valve shall be as per the agreement between the manufacturer and the purchaser.

- o Disc shall be unseated when dispatched, but care shall be taken to ensure that there is no risk of damage to the disc.
- o When specified, the body ends shall be suitably sealed to exclude foreign matter during transit and storage.
- o Components shipped unattached shall be adequately protected and identified to permit correct field assembly.

13.0 FLOT VALVE

Float valve with pressure PN 10 type PTMT float valve.

14.0 REFLUX VALVE (NON-RETURN VALVE)

Specifications shall conform to IS – 5312 or its latest update.

Materials

The materials used for the manufacture of different component parts shall conform to the requirements given in IS 5312 – 2004 or its latest update.

Materials of Construction

Sr. No.	Component	Material
(a)	Body, cover, door, bearing holder and Doors/Disc/Plate	Grey Cast Iron: IS 210 Gr. FG 260
(b)	Hinge Pin/ Door Pin and Door Suspension pin	Stainless steel: IS 6603
(c)	Body Seat rings	Leaded tin bronze, IS 318
(d)	Door Face ring	Leaded tin bronze
(e)	Bearing Bushes / Bearing Block	Leaded tin bronze
(f)	Plugs for hinge pin/ Air release plug	Leaded tin bronze
(g)	Bolts	Carbon Steel, IS 1363
(h)	Nuts	Carbon Steel, IS 1363
(i)	Gaskets	Rubber, IS 638
(j)	Hinges	Grey Cast Iron, IS 10

DESIGN AND MANUFACTURE

Body

The body may be made in two parts - inlet shell and outlet shell. The inlet shell shall have duck foot support.

Diaphragm

Diaphragm shall be fitted between inlet and outlet shells. The parts in the diaphragm should be so designed as to induce minimum head loss in the flow through the valve.

TECHNICAL SPECIFICATION

Water Way Area

The area of the waterway through the multi- doors in the diaphragm shall not be less than the bore area except that this area may be reduced by not more than 15 percent for any proprietary designs.

Inlet and Outlet Shell Connections

The attachment of the inlet to outlet shell of the body shall be adequate to withstand the appropriate test pressures, service conditions and the mechanical loads encountered in the operation. All valves shall have bolted connection. Size of the bolts or studs shall not be less than 22 mm.

Seats

Seat rings shall be so fitted as to avoid their becoming loose in service. Standard countersunk screws shall not be used. 6.6 Door - The door shall be integral with the hinge and shall have a flat seating face.

Lugs

Suspension lugs shall be cast integrally on the diaphragm plate and shall be of adequate strength.

Number of Doors

The minimum number of doors (discs) in the diaphragm plate shall be two.

By-Pass Connection

By-passes are not standard items on valves to the design, but if required, it is recommended that they shall be made for connection between the inlet and outlet shell of the valve. By-passes shall conform to PN 1 of IS: 780-1984* and the minimum size of the by-pass arrangement shall be as indicated in respective IS.

Coating

All coatings shall be carried out after satisfactory testing of the valves prior to dispatch. All the un-machined ferrous surfaces of the valve (both inside and outside) shall be thoroughly clean, dry and shall be free from rust and grease before painting. All exposed machined ferrous surfaces shall be painted with one coat of aluminium red oxide primer. Two coats of black Japan conforming to Type B of IS 341 or paint conforming to IS9862 or IS2932 shall be applied by brush or spray for exterior application in colour as approved by the purchaser.

Testing

Each valve shall be subjected to following hydrostatic tests as specified in IS.

- a. Hydrostatic Body Test
- b. Hydrostatic Seat Test

TECHNICAL SPECIFICATION

Inspection

The purchaser or his authorized representative shall have free access to the works of the manufacturer at all reasonable times to inspect the valve at any stage of manufacture and to reject any material which does not conform to the specified requirements.

Marking

Following information shall be cast on each valve body in raised letter)

- a) Manufacturer's name or trademark.
- b) Nominal pressure of valve (PN1.0 or PN1.6).
- c) Size of valve, mm.
- d) Direction of flow; and
- e) Heat No. of cast.

BIS Certification Marking – Each valve may also be marked with the Standard Mark.

Lowering And Jointing in Position

Supply of Material

Cast Iron double-flanged valves with two tailpieces suitable to pipe conforming to the latest relevant IS shall be supplied and carted by the contractor to the site of work including loading, unloading and stacking at site.

The valves and tailpieces shall be examined before laying for cracks and other flaws. They shall be undamaged in all respect.

The valves shall be cleaned before laying.

All grits and foreign materials shall be removed from the inside of the valves before placing.

All the four faces shall be thoroughly cleaned and coated with a thin layer of mineral grease.

The tightening of gland shall be checked with a pair of inside-calipers. Clearance between the top of stuffing box and the underside of the gland shall be uniform all the sides.

Jointing Material

The contractor shall provide all necessary jointing materials such as nuts bolts, rubber packing, white zinc, jute, lead wool etc.

All tools and instruments, which are to be required for installation of sluice valve shall be provided by the contractor.

All jointing materials shall be got approved from the engineer-in-charge before use.

The nuts and bolts shall conform to the relevant IS.

The rubber packing shall conform all specifications as narrated in respective IS.

TECHNICAL SPECIFICATION

Installation

The valve shall be lowered into the trench carefully, so that no part is damaged during lowering operation.

If necessary, tailpieces shall be fitted with sluice valve first outside the trench and then lowered into the trench.

The rubber packing shall be three ply and of approved thickness. The packing shall be of full diameter of the flange with necessary holes and the sluice valve bore. It shall be even at both the inner and outer edges.

The flange faces thoroughly greased.

If flange faces are not free, the contractor shall use thin fibers of lead wool.

After placing the packing, nuts and bolts shall be inserted and tightened to make the joint.

The valve shall be tightly closed when being installed to prevent any foreign materials from getting in between the working parts of the valve.

Each flange bolt shall be tightened a little at a time taking care to tighten diametrically opposite bolts alternatively.

The valve shall be installed in such a way that its Spindle shall remain in truly vertical position.

The other end of tailpiece shall be fitted with pipes so that continuous lines can work.

Extra excavation required for facility of lowering and fixing valve shall not be paid for.

Testing

After installation of valve the same is tested to 1½ times of its test pressure or as specified in the IS.

The joints of valve shall withstand the test pressure of pipelines.

Defects noticed during test and operation of valve shall be rectified by the contractor at his own cost without any extra claim to the entire satisfaction of the Engineer-in-charge.

Measurement and payment

The rate shall be paid as per Schedule of Payment per number of valves fixed and tested as directed.

15.0 Y -STRAINER

Supply, installation, testing and commissioning of CI Y strainer approved make and best quality conforming to latest IS , PN 10.0, with necessary specials, etc. for pump suction header and wherever required, to complete the job.

TECHNICAL SPECIFICATION

16.0 GREASE TRAP

Prefabricated Grease separator shall be of HDPE / Polyethylene conforming to EN 1825 / DIN 4040 / 100 suitable for underground/above ground installation with integrated sludge trap, sloped interior base improves cleaning and reduces disposal time, inlet flow calming system and outlet flow regulation device, inlet and outlet interchangeable, slanted twin access covers with quick release odor tight snap closures, inspection window with interior cleaning arm. The contractor shall refer drawings for selection.

Grease separator shall have mix & pump version manually controlled odor free disposal, cleaning and refilling system at touch of button, maintenance free pump for separator cleaning and disposal, includes closure valve for easy pump removal, pump floor mount included with installation hardware and anti-vibration matt, manual hand valve for transfer from cleaning to disposal mode, of adequate pumping capacity, with necessary cabling, top mounted water jet(s) for grease layer breakup and water spray nozzles for interior wall cleaning during disposal, manual hand valve for water refill with interior threaded refill inlet with air gap as per manufacturer specification.

LIFTING STATION FOR OIL TRAP

Pressure sensor controlled single or twin wastewater pumps with multi-vane impeller to pump wastewater with or without sewage (open channel passage 40 mm). Pump shall be rated submersible (IP 68) with necessary cabling and sound-absorbing underlay mat (10 mm thick) or as per manufacturer specification.

Pump arrangement shall be vertical/ horizontal outlet with integrated non-return valve, with/without closure valve (provided loose), with hose section or flange.

GREASE INTERCEPTOR

Prefabricated Grease separator shall be of HDPE / Polyethylene conforming to EN 1825 / DIN 4040 / 100 suitable for underground/above ground installation with integrated sludge trap, sloped interior base improves cleaning and reduces disposal time, inlet flow calming system and outlet flow regulation device, inlet and outlet interchangeable, slanted twin access covers with quick release odor tight snap closures, inspection window with interior cleaning arm. The contractor shall refer drawings for selection.

Grease separator shall have mix & pump version manually controlled odor free disposal, cleaning and refilling system at touch of button, maintenance free pump for separator cleaning and disposal, includes closure valve for easy pump removal, pump floor mount included with installation hardware and anti-vibration matt, manual hand valve for transfer from cleaning to disposal mode, of adequate pumping capacity, with necessary cabling, top mounted water jet(s) for grease layer breakup and water spray nozzles for interior wall cleaning during disposal, manual hand valve for water refill with interior threaded refill inlet with air gap as per manufacturer specification.

17.0 AIR RELEASE VALVE

Scope

Supplying and erecting air release cock of 25mm made from GM with necessary G.I. coupling for fixing on pipeline.

Material

TECHNICAL SPECIFICATION

Air release valve: Gun metal
Coupling: G.I.

Method of Construction

Air release valve with necessary GI coupling shall be fixed on pipeline with required labour, tools etc.

Method of measurement

Executed quantity shall be measured on number basis.

18.0 BLANK FLANGE

Blank flanges shall use at non-used / spare puddle flange. Jointing shall be done with bolts, nuts, washers and rubber insertion 3 mm thick, testing the flange and joints etc.

MATERIAL

Blank flange fabricated out of 6 mm thick MS plates of suitable size shall be used.

FIXING

Blank flange shall be fixed in position with appropriate location during execution phase.

19.0 GARDEN HYDRANT AND GARDEN HOSE PIPE

Supply, Installation, Testing and Commissioning of Garden Hydrant with gun metal Ball Valve, Hose reel, Flexible hose Connection Provision and all required accessories etc.

20 mtr. Length 20 mm garden hose pipe.

20.0 WOLTMAN TYPE BULK WATER METER- AMR BASED

Woltman Type Bulk Water Meter- AMR Based:

Design, Supply, Installation, Testing, Commissioning of Woltman type Bulk Water Meter, CI/ Brass/ Bronze body material, totalizer made of copper can/ suitable anti corrosive metallic material, totaliser metallic shall have 5 mm thick glass cover suitable against antifraud attempts, Flange End process connection, IP 68 protection class; AMR Woltman Type Water Meter with removable mechanism, magnetic drive, dry dial, and be fitted with a low mass rotor which is parallel to the direction of water flow and exhibits dynamic thrust relief, water meters complete with T Type strainer, ISO 4064 : 2005 with valid CE mark mentioning notified body number along with MID / OIML / ISO certification from a recognized International laboratory.

AMR System:

AMR System shall be Walk By / Drive By mode, Wireless AMR trans-receivers shall be directly fitted on meter or inbuilt, IP 68 protection class, water meter & AMR Module shall be of same brand, Single Command based AMR Reading and Minimum 90 days historical data retrieve

TECHNICAL SPECIFICATION

facility, alarm indication/ recording (for Reverse Flow, back flow, Peak Flow, Minimum Flow, Low Battery Alarm, Volume below threshold, Volume above threshold, Reverse Meter, Meter Stopped), Minimum 10 years of AMR module battery life considering one no. communication per day.

21.0 MOSQUITO PROOF GRATING

Providing and fixing 100 mm dia. mosquito proof stainless steel overflow grating for tanks

22.0 R.C.C. PIPES

SCOPE :

This specification covers the requirements for manufacture, supplying, lowering, laying, jointing, testing and commissioning of reinforced cement concrete (RCC) pipes used for the conveyance of sewage & storm water .

CODES & STANDARDS :

The manufacturing, testing, supplying, jointing and testing at work sites of RCC pipes shall comply with all currently applicable statutes, regulations, standards and codes. In particular, the following standards, unless otherwise specified herein, shall be referred.

MATERIALS

IS : 458 Specification for pre cast concrete pipes (with and without reinforcement)

IS : 3597 Method of tests for concrete pipes.

IS : 432 Specification for mild steel and medium (tensile steel bars and hand drawn steel) wires for concrete reinforcement.

IS : 5382 Specification for rubber sealing rings for gas mains, water mains & sewers

IS : 516 Method of test for strength of concrete.

CODE OF PRACTICE

IS : 456 Code of practice for plain and reinforced concrete

DESIGN

Design of RCC pipes including reinforcement details and the ends of pipes shall be in accordance with the relevant clauses of IS : 458.

GENERAL

The method of manufacture of RCC pipes (Class NP 3) shall be such that the form and the dimensions of the finished pipes are accurate within the limits specified in relevant clause of IS : 458. The surfaces and edges of the pipes shall be well defined and true, and their ends shall be square with the longitudinal axis. The ends of the pipes shall be further reinforced by an extra ring of reinforcement to avoid breakage during transportation.

TECHNICAL SPECIFICATION

The RCC pipes and rubber rings shall be systematically checked for any manufacturing defects by experienced supervisors so as to maintain a high standard of quality.

The engineer shall at all reasonable times have free access to the place where the pipes and collars/rubber rings are manufactured for the purpose of examining and testing the pipes and collars/ rubber rings and of witnessing the test and manufacturing.

All tests specified either in this engineer's requirements or in the relevant Indian standards shall be performed by the supplier/contractor at his own cost and in presence of the engineer if he so desires. For this, sufficient notice before testing of the pipes and fittings shall be given to the engineer.

If the test is found unsatisfactory, the engineer may reject any or all pipes of that lot.

MATERIALS

CEMENT

Sulphate resisting cement shall be used for the manufacture of RCC pipes and fittings and shall conform to IS 12330.

AGGREGATES

Aggregates used for the manufacture of RCC pipes shall conform to 3 of IS : 383. The maximum size of aggregate should not exceed one third the thickness of the pipe or 20mm, whichever is smaller for pipe size above 250 mm. For 80 to 250 mm size, the maximum size of the aggregate shall be 10 mm.

MIXING AND CURING WATER

Water shall be clean, colourless & free from objectionable quantities of organic matter, alkali, acid, salts, or other impurities that might reduce the strength, durability or other desirable qualities of concrete and mortar.

REINFORCEMENT

Reinforcement used for the manufacture of the reinforced concrete pipe shall conform to mild steel Grade 1 or medium tensile steel bars conforming to IS : 432 (part-1) or hard-drawn steel wire conforming to IS : 432 (part-2) or structural steel (standard quality) bars conforming to IS 2062. Reinforcement cages for pipes and collars shall be as per relevant requirement of IS : 458.

CONCRETE

Concrete used for the manufacture of RCC pipes shall conform to IS : 456. The minimum cement content and minimum compressive strength of concrete shall be as per relevant requirements of IS : 456. Compressive strength tests shall be conducted on 15 cm cubes in accordance with the relevant requirements of IS : 456 and IS : 516.

CURING

Pipes manufactured in compliance with IS : 456 shall be water cured in accordance with the relevant requirements of IS : 456.

TECHNICAL SPECIFICATION

DIMENSIONS & TOLERANCE

The internal diameter, wall thickness and length of barrel, reinforcement (longitudinal and spiral), type of ends and minimum clear cover to reinforcement and strength test requirements shall be as per the relevant clauses / tables of IS : 458 for class NP3 RCC pipes.

The tolerances regarding overall length, internal diameter of pipes or sockets and barrel wall thickness shall be as per relevant clause of IS : 458.

WORKMANSHIP & FINISH

Pipes shall be straight and free from cracks except that craze cracks may be permitted, the ends of the pipes shall be square with their longitudinal axis.

The outside and inside surfaces of the pipes shall be smooth, dense and hard, and shall not be coated with cement wash or other preparation unless otherwise agreed to between the engineer and the manufacturer or supplier.

The pipes shall be free from defects resulting from imperfect grading of the aggregate, mixing or moulding.

The pipes shall be free from local dents or bulges greater than 3 mm in depth and extending over a length in any direction greater than twice the thickness of barrel.

The deviation from straight in any pipe throughout its effective length, tested by means of rigid straight edge parallel to the longitudinal axis of the pipe shall not exceed, for all diameters 3 mm for every meter run.

TESTING

All pipes for testing purposes shall be selected at random from the stock of the manufacturer and shall be such as would not otherwise be rejected under the criteria of tolerances as mentioned in IS : 458.

During manufacture, compressive strength of concrete cubes shall be done as described in IS 516. For pressure pipes, splitting tensile strength tests of the concrete cylinders shall be carried out as described in IS 5816. The manufacturer shall supply, when required to do so by the engineer, the results of compressive tests of concrete cubes and split tensile tests of concrete cylinders made from the concrete used for the pipes; the manufacturer shall supply cylinders or cubes for test purposes required by the engineer and such cylinders or cubes shall withstand the tests prescribed as per IS : 458. Every pressure pipe shall be tested by the manufacturer for the hydrostatic test pressure, for non-pressure pipes, 2 percent of the pipes shall be tested for hydrostatic test pressure in accordance with IS 458.

The specimen of pipes for the following tests shall be selected in accordance with relevant clause of IS : 458 and tests in accordance with the methods described in IS : 3597.

Hydrostatic Test
Three-edge bearing Test
Permeability Test

SAMPLING & INSPECTION

TECHNICAL SPECIFICATION

In any consignment, all the pipes of same class and size and manufactured under similar conditions of production shall be grouped together to constitute a lot. The conformity of a lot to the requirements of this specification shall be ascertained on the basis of tests on pipes selected from it.

The number of pipes to be selected from the lot for testing shall be in accordance with table 22 of IS : 458.

Pipes shall be selected at random. In order to ensure randomness of selection, all the pipes in the lot may be arranged in a serial order and starting from any pipe, every pipe shall be selected till the requisite number is obtained and or procedures given in IS 4905 may be followed.

All pipes selected shall be inspected for dimensional requirements, finish and straightness. A pipe failing to satisfy one or more of these requirements shall be considered as defective.

The number of pipes to be tested for tests under clause 10.2 shall be in accordance with column 4 of table 22 of IS : 458. These pipes shall be selected from pipes that have satisfied the requirements of dimensions, finish and deviation from straight.

A lot shall be considered as conforming to the requirements of IS : 458 if the following conditions are satisfied.

The number of defective pipes (those not satisfying one or more of the requirements for dimensions, finish and deviation from straight shall not be more than the permissible number given in clause 8 & 9 of IS : 458.

All the pipes tested for various tests as per Clause shall satisfy corresponding requirements of the tests.

In case the number of pipes not satisfying requirements of any one or more tests, one or two further samples of the same size shall be selected and subjected to the test or tests in which the failure has occurred. All these pipes shall satisfy the corresponding requirements of the test. In the event they do not, the lot will be rejected.

MARKING

The following information shall be clearly marked on each pipe :

Internal diameter of pipe

Class of pipe

Date of manufacture and

Name of manufacturer or his registered trademark or both.

CARTING & HANDLING

Unless waived by the engineer, method statements shall be submitted by the contractor for the approval of the engineer before the handling, transportation and laying of any

TECHNICAL SPECIFICATION

pipes commences. All pipes shall be handled and stored in compliance with the manufacturer's recommendations. Pipes and fittings /specials shall be transported from the factory to the central pipe store and unloaded there before being transported to site. At every point of loading or unloading, all pipes and fittings shall be lifted using approved lifting tackle. Unloading by rolling down any form of inclined ramp will not be permitted. Pliable straps or slings shall be used to lift pipes. Rope, wire rope, hooks or chains shall not be allowed to come into contact with any pipe surface. All pipes shall be thoroughly inspected on arrival on site and immediately prior to installation. Any damage to the pipes shall be notified to the engineer for a decision as to the acceptability of the pipes, with or without repairs or remedial work. The final judgement will be taken by the engineer based on his judgement of the suitability of the items for the purpose intended.

STORAGE

Each stack of pipes shall contain only pipes of same class and size, with consignment or batch number marked on it with particulars of suppliers wherever possible. Storage shall be done on firm level and clean ground and wedges shall be provided at the bottom layer to keep the stack stable. The stack shall be in pyramid shape or the pipes laid lengthways and crosswise in alternate layers. The pyramid stack shall be made for smaller diameter pipes for conserving space in storing them. The height of the stack shall not exceed 1.5 m.

Rubber rings shall be stored in a clean, cool store away from windows, boiler, electrical equipment and petrol, oils or other chemicals.

PIPELINE CONSTRUCTION (GENERAL)

Pipes shall be laid and jointed in accordance with all relevant recommendations of the manufacturer. Any variations between the manufacturer's recommendations and this specification shall be highlighted in the contractor's method statements and a ruling will be given with the approval. All pipelaying shall be performed by experienced and competent pipelayers.

The line of the pipe shall be set out and agreed with the engineer well in advance of the excavation. Surface stripping, excavation, pipelaying, backfilling and reinstatement shall follow each other without undue delay or interval between these activities.

LAYING OF PIPES

In laying the pipes and fittings/ specials the center for each manhole / chamber or pipeline shall be marked by a peg. Contractor shall dig holes for and set up two posts (about 100 x 100 x 1800 mm) at each manhole / chamber or junction of pipelines at nearly equal distance from the peg and at sufficient distances there from to be well clear of all intended excavation, so arranged that a sight rail when fixed at a certain level against the post shall cross the center line of the manhole/chamber or pipe lines. The sight rail shall not in any case be more than 30 m apart, intermediate rails shall be put up if directed by engineer.

Boning staves of 75 mm x 50 mm size shall be prepared by contractor in various lengths, each length being of a certain whole number of meters and with a fixed tee head and fixed intermediate cross pieces, each about 300 mm long. The top-edge of the cross piece must be fixed below the top-edge of the tee-head at a distance equal to the outside

TECHNICAL SPECIFICATION

diameter of the pipe or the thickness of the concrete bed to be laid as the case may be. the top of cross pieces shall indicate different levels such as excavation for pipe line, top of concrete bed, top of the pipe etc. as the case may be.

The sight rail of size 250 mm x 40 mm shall be screwed with the top edge resting against the level marks. The centre line of the pipe shall be marked on the rail and this mark shall denote also the meeting point of the centre lines of any converging pipes. a line drawn from the top edge of one rail to the top edge of the next rail shall be vertically parallel with the bed of the pipe, and the depth of the bed of pipe at any intermediate point may be determined by letting down the selected boning staff until the tee head comes in the line of sight from rail to rail.

The post and rails shall be perfectly square and planed smooth on all sides and edges; the rails shall be painted white on both sides, and the tee-heads and cross-piece of the boning staves shall be painted black.

For the pipes converging to a manhole/chamber at various levels, there shall be a rail fixed for every different level. when a rail comes within 0.60 m of the surface of the ground, a higher sight-rail shall be fixed for use with the rail over the next point. the posts and rails shall in no case be removed until the trench is excavated, the pipes are laid and engineer gives permission to proceed with the backfilling.

LAYING OF PIPES & FITTINGS/SPECIALS

The joints and interiors of all pipes and fittings shall be carefully cleaned before installation, whenever pipelaying is interrupted for any reason, the open end of the pipeline shall be sealed with a suitable expanding stopper or a properly fitted temporary wooden stopper and exposed pipes shall be suitably protected from stones and other objects falling into the trench from above.

The permissible tolerance for pipelines in trenches shall be 6mm in level and 25mm in line between manholes. After the laying of a length of a pipeline but before testing the crown of the pipe shall be checked for level and alignment and any necessary adjustment made by unjointing and removing the pipes concerned, adjusting the bedding, relaying the pipes and rechecking for line and level.

For pipeline jointing systems incorporating flexible jointing rings, pipes shall be laid with the spigot end pointing in the direction of flow and with a gap between the end of the spigot and the base of the socket, or between spigots, rubber rings shall comply to IS : 5382.

JOINTING

Pipe section shall be joined utilising spigot and socket flexible joint with rubber ring, as per relevant IS after jointing, extraneous material, if any, shall be removed from the inside of the pipe and the newly made joints shall be thoroughly cured. the rubber sealing rings used for jointing, shall conform to IS : 5382.

The RCC pipe with the rubber ring accurately positioned on the spigot shall be pushed well home into the socket of the previously laid pipe by means of uniformly applied pressure with the aid of a jack or similar appliance. The RCC pipes shall be of spigot and socket type and rubber rings shall be used, and the manufacturer's instructions shall be deemed to

TECHNICAL SPECIFICATION

form a part of these engineer's requirements. The rubber rings shall be lubricated before making the joint and the lubricant shall be soft soap water or an approved lubricant supplied by the manufacturer.

BEDDING

The type of bedding for the RCC pipes (granular, concrete cradle – PCC, RCC, concrete encasement, etc.).

GRANULAR BEDDING

Material used for bedding should be of granular material, free from sharp edges and sharp angles, well graded and durable under influence of ground water. The material selected shall consist of gravel (uncrushed or crushed), crushed rock or crushed concrete. uncrushed gravel is obtained from the natural disintegration of rock.

Well graded gravel of varying size from 5 mm to 14 mm shall be used. percentage distribution of each size for graded aggregate is mentioned in table 2.1 below.

Where pipes are laid with a granular bed or surround the appropriate bedding material shall, as soon as a section of trench has been trimmed to grade, be placed carefully over the full trench width without segregation. The material shall be spread and thoroughly compacted by approved mechanical means in successive uniform layers each not exceeding 150 mm compacted thickness to produce a uniform bed to the required gradient. where plate vibrators are used, there shall be a minimum of one pass for crushed stone and two passes for sands. hand tamping will only be permitted where insufficient space is available to allow the use of mechanical plant. the minimum thickness of compacted granular material shall be as follows:-

150mm (minimum 100mm under sockets) for pipes not exceeding 300mm nominal diameter, except when trench is in rock.

200mm (minimum 100mm under sockets) for pipes greater than 300mm nominal diameter, or all pipes when trench is in rock.

The pipes shall then be set evenly on the bed, great care being taken to ensure uniform support for the entire length of the pipe.

Pockets in the bedding shall be formed at each pipe joint to permit jointing to be carried out without the sleeve or socket of the pipe joint bearing on the bedding material and without bedding material entering the joint.

After the pipeline alignment and joints have been inspected and approved by the engineer, the water testing of the pipeline satisfactorily completed, and, where appropriate, the annular gap at each pipe joint sealed, each joint pocket shall be carefully filled with granular material and thoroughly compacted up to the same level as the top of the bedding. granular bedding material of the same type shall be placed on both sides of the pipeline in successive uniform layers not exceeding 150mm thick and compacted according to one of the methods given in table 2.2 as agreed with or directed by the engineer. care shall be taken to ensure that no cavities remain under the pipe, and that the pipes are not displaced by differential pressure from either side.

TECHNICAL SPECIFICATION

When placing and compacting surround material the contractor shall take care not to displace or damage the pipes, the tipping of surround material from ground levels directly onto the pipes shall not be permitted.

Unless otherwise detailed on the drawings, for pipes with a full granular surround the granular material shall extend up to a minimum height of 300mm over the crown of the pipes, for rigid pipes unless otherwise detailed, the granular material shall extend up to the springing level of the pipe, the surround shall be completed by the careful placing of selected excavated material in layers not exceeding 150mm thick, thoroughly compacted on both sides of the pipeline to a level at least 300mm above the crown of the pipes.

For pipelines of 600mm diameter or greater the bed should be prepared ahead for approximately two pipe lengths whilst two pipes are being laid and the previous two pipes are receiving side filling, for pipelines less than 600 mm diameter the lengths of each stage shall be agreed with the engineer.

If the contractor wishes to use any other method of laying pipes in granular bedding or surround he must submit his proposals in writing to and obtain the approval in writing from the engineer well in advance of the date when he wishes to perform the work.

CONCRETE BEDDING

Concrete shall be grade M 20 unless otherwise detailed on the drawings / BOQ.

The minimum thickness of concrete between the bottom of the pipe and the trench shall be 0.25 x nominal pipe diameter, subject to 150mm minimum, with a minimum 100mm beneath sockets.

The pipes shall be set to correct alignment as detailed below :-

The contractor may use rectangular concrete blocks (two per pipe) made of grade M15 concrete, cast at least 7 days before use, together with pairs of approved hardwood wedges of the same width as the blocks in order to align and support the pipe before concreting, the blocks and wedges shall be of sufficient size and suitably founded on the bottom of the trench to support the pipe adequately without settlement or movement at any stage, the blocks and wedges should be placed near the end of each pipe length and should be left undisturbed during jointing of subsequent pipes and during construction, although the wedges should be removed during placing of the concrete.

Blocks may have thin tie wires cast in to assist in holding down the pipe when the concrete surround is being mechanically vibrated.

After approval of the joints and satisfactory testing of the pipeline a transverse flexible joint shall be formed by insertion of a template of compressible joint filler consisting of bitumen impregnated insulating board as per BS 1142 part 3 or other equally compressible material shaped exactly to the pipe and full extent of the concrete cradle or surround, unless otherwise specified, the thickness of this flexible joint shall be a minimum of 25mm.

For spigot and socket pipes, the flexible joint in the concrete shall be aligned with the face of the socket. For sleeve type and flexible mechanical joints, the flexible joint shall be

TECHNICAL SPECIFICATION

aligned with one end of the sleeve or mechanical joint. In certain cases, a flexible joint may be required at both ends of the sleeve or mechanical joint. The concrete infill for flexible mechanical joints shall only be placed after the application of the specified protection materials to the joint. no steel reinforcement shall pass through the flexible joint.

Concrete for beddings, surrounds and joint infills shall be placed carefully and uniformly, suitable measures being adopted to ensure that the pipeline is not displaced by differential side pressure or by flotation. Concrete shall be properly compacted with particular care being taken to ensure that no cavities are left underneath the pipe.

The concrete shall provide a minimum cover to the pipe of 150mm for surrounds. Concrete beds to pipes of all diameters and surrounds to pipes of one metre diameter or less shall be poured in a single operation. concrete surrounds to pipes over one metre diameter shall normally be poured in two lifts, with a horizontal joint not more than 100mm below the crown of the pipe. concrete shall be prevented from entering pipe joints.

Formwork shall be used for all vertical faces. Side forms should not normally be required, if trench widths specified are such that the concrete bedding / surround will extend the full width of the trench.

All formwork used for forming the concrete bedding shall be removed, unless the written approval of the engineer is given to leave it in place for safety or similar reasons. Where side forms have been required, backfilling shall be proper to fill the voids left on removal of the formwork.

The bedding and surround shall be completed by the careful placing of selected excavated material in layers not exceeding 150mm thick, thoroughly compacted by hand on both sides of the pipeline to a level at least 300mm above the crown of the pipes. as this material is placed and compacted in the trench, the supports to the sides of the trench shall be concurrently partly withdrawn so that there are no voids or uncompacted zones.

Except where otherwise specified or instructed by the engineer, no traffic load may be imposed upon the trench within 72 hours of the placing of the concrete cradle or surround.

If the contractor wishes to use any other method of laying pipes in concrete cradle or surround, he must submit his proposals in writing to and obtain the approval in writing from the engineer well in advance of the date when he wishes to perform the work.

SPECIAL FOUNDATION IN POOR SOIL

Where the formation of the trench is found to consist of material which is unstable to such a degree that in the opinion of the engineer, it cannot be removed and replaced with an approved material thoroughly compacted in place to support the pipe properly, a suitable foundation for the pipes, consisting of piling, timbers or other materials shall be prepared by the contractor and as instructed by engineer.

INSPECTION OF PIPELINES

As soon as the pipeline has been completed from manhole to manhole the contractor shall run through the pipes both backwards and forwards a double disc or solid or closed cylinder 75 mm less in diameter than the internal diameter of pipes.

TECHNICAL SPECIFICATION

If as a result of the removal of any obstructions the engineer considers that damages may have been caused to the pipe lines, he shall be entitled to order the stretch to be tested immediately. should such test prove unsatisfactory, contractor shall make good the pipeline and carry out such further tests as are ordered by the engineer.

SITE TESTING

After laying & jointing of RCC pipes is completed the pipe line shall be tested. All equipment for testing shall be supplied by the contractor. damage during testing shall be contractor's responsibility and shall be rectified by him to the full satisfaction of the engineer. water for testing of pipeline shall be arranged by the contractor at his own cost.

After the joints have been checked by the engineer and before backfilling of the trenches, the entire section of the sewer shall be proved by the contractor to be watertight by filling the pipes with water to the level of 1.50m above the top of the highest pipe in the stretch and heading the water up for a period of one hour. the apparatus used for the purpose of testing shall be approved by engineer. the contractor if required by the engineer shall de-water the excavated pit and keep it dry during the period of testing. The loss of water over a period of 30 minutes shall be measured by adding water from a measuring vessel at regular 10 minutes intervals and noting the quantity required to maintain the original water level. for acceptance of the section of pipeline under test the average quantity added shall not exceed 1 litre/ hour/100 linear metres / 10mm of nominal internal diameter. any leakage including excessive sweating which causes a drop in the test water level in excess of the permitted amount will result in the pipeline being rejected. the contractor will be required to remove and re-lay the pipeline for re-testing.

Water used for the test shall be removed from pipes and not discharged to the excavated trenches.

23.0 HYDROPNEUMATICS SYSTEM:

Scope:

The specification covers design, performance, manufacture, construction features, inspection, testing, delivery, installation, commissioning of Hydro pneumatic pressurized system consisting of balancing tank with mounting pads, pump-motor set with coupling and coupling guard, common base plate, bell mouth, piping, isolation valves, NRVs, fittings, control panel, pressure switches, Foundation SS Nut, SS washers, SS bolt, antivibration pad, suction header Pipe and Valve from UG tank to Pump, Strainer, Suction, discharge and All flanged end, pumps & allied piping and accessories, expansion bellow, Completing the pipe alignment at the joint of discharge header to supply pipe with bolts nuts & rubber packing, chain pulley block with endless chain, Electrical Panel, Cable, cable tray up to pump panel and other accessories required for complete installation of hydro pneumatic system at site.

Compact self-contained Hydro-booster system factory fabricated and fitted, fully integrated comprising of following :

In-line, vertical multistage, centrifugal clear water pumps with SS-304 casing, S.S 304 impeller and SS-304 shaft, C.I. Base CED (Cathode Electrode Deposition) coating & head TEFC motor (with mechanical seal), dry run protection, antivibration paid, 2 pole Motor & IE3 Efficiency.

TECHNICAL SPECIFICATION

Panel mounted microprocessor based multi pump controller with large graphical display with VGA 240 x 320 pixels and variable frequency drive (VFD) integrated in a single body, pressure sensor transmitter, IP 55 enclosure, diodes to indicate pump ready, earthing, pump running and fault condition, Cascade Operation. Each incoming and Outgoing feeder should be capable for protection against Overload, Short Circuit and Phase reversal condition and shall be capable to communicate with other controllers following. The PLC shall support MODBUS-IP communication for its compatibility to integrate with 3rd party BAS system. Controller shall authorize Read/Write command via BMS. System should be capable to compensate for frictional losses at lower flows. All alarms should be displayed in the controller. System should be equipped with dry running protection. Indication of all type of faults / on-off status / electrical parameters shall be available on panel and central IBMS monitors. On-off operation for all pumps shall be available on BMS system.

Electronic type low water level controller with LED panel to operate pump (necessary contacts along with minimum one PLC operated spare contacts required), with probe & all control wiring from Panel to tank to operate the system automatic/manual & shall prevent the pump from dry running.

Scope shall also include power and control cable of required size, termination, cable tray from Pump to Control panel, control cable as wherever required etc. complete the job.

Pre-charged diaphragm pressure vessel PN 10 with interchangeable membrane, charging connection, connected to outlet header with necessary pipe, flanges, gaskets, isolating valves, nuts/bolts etc. complete.

Set of accessories such as GI C Class headers of suction and discharge for (working and Assist by pump assembly) with CED Coating, cast iron control valves, Cast Iron non return valves, pressure transducers, pressure gauge with Isolation Valve of PN 10 etc. complete the job. Require complete company fitted ready-to-connect packaged system. Pumping system shall be as per GRHA Norms.

The items/quantities shall be measured and paid upon completion of the linked milestone as per schedule 10 for the respective item.

Construction features:

The major components of the system shall be as follows:

A. PRESSURE VESSEL:

FRP tank (Pressure vessel) for min. 10 Kg/cm² Pressure rating with inbuilt aircell to be provided if specified in BOQ.

FRP Tank shall be tested at Factory as well as site before installation.

The tank shall be provided with all accessories viz. mounting arrangement, isolation valve, pressure gauge, etc.

B. PUMP:

TECHNICAL SPECIFICATION

Inline vertical multistage pump shall be provided. Variable frequency drive shall be provided with one of the installed pump – if specified in Schedule of quantity.

The pump – motor set and shall be suitable for 3 Ph., 415 V, 50 Hz. AC power supply and having 2900 RPM speed. The pump shall be installed with isolation butterfly valve, non return valve, etc. The detailed specification for pump & motor is as below:

Vertical inline Pump

C. Codes & Standards :

The design and manufacture of the pump shall comply with all currently applicable statutes, regulations and safety codes in the locality where the equipment will be installed.

D. Design Features:

The pump shall be capable of developing required total head at rated capacity. Impeller shall be closed type and shall be dynamically balanced. The pump shall have non overloading characteristics.

E. Constructional Features:

The casing shall be of rigid construction and shall have side suction and side delivery in case of inline pump and side suction and central delivery in case of submersible centrifugal pump.

The pump shall have very small length suction and delivery pipe connections which will result in minimum friction loss.

Impeller shall be of one piece and shall be of SS CF8 M.

The shaft shall be of S.S. and its surface shall be properly finished.

Shaft sleeves shall be provided to protect shaft from any damage.

Bearing shall be ball or roller type.

Mechanical seal shall be provided to avoid any leakage.

F. Inspection & Testing:

The pump shall be offered for visual inspection before dispatch.

Material test certificates for the various pump components shall be furnished for purchaser's approval.

Hydrostatic test shall be carried out at 1.5 times the maximum discharge pressure.

TECHNICAL SPECIFICATION

All the tests shall be witnessed by purchaser.

G. Drawings:

Following drawings shall be furnished by the Contractor:

Overall dimensional drawing,
Cross-sectional drawings with all dimension (vertical and horizontal) with Bill of Material and Material of Construction.

H. Accessories:

The pump shall be provided with all accessories such as base plate, foundation bolts, strainer, pressure gauge, etc. All accessories required for proper and safe operation shall be furnished with the pumps.

I. Pressure transducer:

The system shall be installed with the pressure transducer which shall be set at predetermined pressure to automatically control the pump operation.

J. Drawings:

Following drawings shall be furnished by the CONTRACTOR:

- 1 Overall dimensional drawing.
- 2 Cross-sectional drawings with Bill of Material and Material of Construction.

K. Manifolds, Valves, Base frame & Accessories

- o Suction and Delivery manifolds in Hot Dip Galvanized steel. (80-110micron)
- o DIN standard flange connections.
- o One non-return valve and isolating valves for each pump is provided in delivery side and one isolating valve is provided in suction side.
- o Manifolds and valves are suitable for 16bar pressure rating.
- o Pumps should be mounted on the common base frame.
- o Base frame and panel side support is in Galvanized steel.
- o Suitable range of pressure gauges and pressure transmitter should be connected at the discharge manifolds.
- o Vibration dampening pad for minimize the noise and vibration in the system.
- o Concrete foundation as per manufacturer recommendation. (1.5 times X the weight of the Pumping system).

TECHNICAL DATA SHEET FOR HYDROPNEUMATICS pumping system:

Particular	Data to be filled by Contractor
Pump	
Make	
Type & Model: Vertical Multistage	
Discharge in cum/hr	

TECHNICAL SPECIFICATION

Particular	Data to be filled by Contractor
Head (Meters of WC)	
Number of Pumps	
Total system flow (cum/hr)	
Shut off Head (Meters of WC)	
Efficiency (%)	
No. of Stages	
Suction End I.D.	
Delivery End I.D.	
Details of N.P.S.H.	
Vibration Isolation Detail	
Skid Details	
Operating Weight	
Overall Dimension (MM)	
Mechanical Seal Detail	
Material	
Pump Head - Cast Iron	
Pump Base- Cast Iron	
Impeller-SS 304	
Chamber-SS 304	
Shaft-SS316	
Motor stool-Cast Iron	
Shaft seal Cartridge type(SiC/Carbon)	
Rubber parts-EPDM	
Motor	
Make	
Model	
Power Requirement (HP / KW)	
R.P.M.	
No. of pole: 2 pole	
Efficiency class-IE3	
Insulation class-F	
Enclosure class-IP 55	
Supply Frequency-50Hz	
Supply voltage-3X380-415V	
Built in Thermistor-PTC	
Control Panel	
Enclosure class-IP 55	
DETAILS OF PLC	
DETAILS OF VFD	
Pressure Vessel	
Make	
Model Number	
Material of construction (Vessel/Bladder)	
Dimension	
Overall capacity	
Cut-in/Cut-out setting	
Capacity at specified cut-in/cut-out	

TECHNICAL SPECIFICATION

Particular	Data to be filled by Contractor
Overall dimension of skid mounted system	
Weight (Static/Dynamic)	
ACCESSORIES & SERVICES REQUIRED	
Base Plate	
Foundation bolts	
Companion flanges	
Spare parts required	
Maintenance tools required	
Cut in pressure	
Cut off pressure	
Plant room suction matching flange & outside plant room flange	
Suction & delivery piping: MS, hot dipped galvanized, Class 'C' with CED Coated	
Suction, delivery valves & header valves: Required, flanged Cast Iron valves with SS internal parts. Make: Kirioskar / KSB / AUDCO/ FLOVEL Flanged Ball / Butterfly valve on suction and delivery of each pump & Flanged Non slam, spring operated dual plate type check valve on delivery side of each pump & on header	
Control Panel: With Starter. One pump of similar rating shall have VFD Required with all protections & sequential timer for main pumps. Also required Finolex / CCI / Gloster make cable from motor to panel	
Level Transmitter: Required for 0-5 mtr. Range and shall be panel mounted and interlocking with pump	
Pressure Transmitter	
Pressure Gauge: Required at delivery header.	
Gaskets: 'Champion 'make	
Hardware: Zinc coated	

24.0 DRINKING WATER TREATMENT PLANTS

Reverse-osmosis Automatic, water treatment plant comprising of RO plant etc. according to input water quality/ analysis. The scope shall include interconnection piping, valves, instruments, back wash arrangement, including Raw water inlet pumps a 1 working + 1stand by pump set, micron filter, High pressure pump (1W+1S), and all other required pump set is auto operation, including dry run protection, RO Module, all valve controls, SS 316 interconnecting piping of suction and discharge header, control panel and other necessary cabling works, 2 pole Motor & IE3 Efficiency etc. complete the job. Panel mounted PLC based pump controller, IP 55 enclosure, ON-OFF and Trip Indicating lamps in each incomer and outgoing feeders. The PLC shall support MODBUS-IP communication for its compatibility to integrate with 3rd party BAS system. PLC shall authorize Read/ Write command via BMS. earthing, interlocking arrangement, dry run protection, cascade operation, working / standby selection, with provision of remote on/off operation complete as

TECHNICAL SPECIFICATION

required. The on/off operations for all pumps shall be available on central BMS system. Each incoming and Outgoing feeder should be capable for protection against Overload, Short Circuit and Phase reversal condition and shall be capable to communicate with BMS. Scope shall also include supply, laying, termination of control and power cables of adequate size, and arrangement of cable tray from Pump to Control panel etc. to complete the job. SITC of electronic type low water level controller with LED panel to operate pump (necessary contacts along with minimum one spare contact required), with probe & all control wiring to operate the system automatic/manual & shall prevent the pump from dry running.

Mounting Height : 500mm from the bottom of tank. SITC of electronic type low & high water level controller with LED panel to operate pump (necessary contacts along with minimum one spare contacts required), level controller with operational mode as one pump working at low level, both pumps at high level with a hooter alarm and cut off at dry level with probe & all control wiring to operate the system automatic/manual & shall prevent the pump from dry running.

Mounting Height (Low Level) : 500mm from the bottom of tank.

Mounting Height (High Level) : free board level of tank. All Automatic valve to be Electronic operated.

All Pumping systems shall be as per GRIHA Norms.

25.0 SS STORAGE TANK:

SS 316 Drinking Water storage tank, Working Pressure - 6 Bar, test pressure shall be 1.5 times with flanged connection as required, capable of storing Cold water insulated with 50 mm thick PUF Insulation with 26 swg aluminium cladding. Shell shall be fabricated with 3 mm thick plate and dished ends with 3 mm thick plates: complete with manhole cover, safety valve drain, nozzle, inlet and outlet nozzles industrial type temperature indicator. The storage tank shall be provided with Manhole Cover, item including of necessary supporting stand etc. complete the job.

26.0 WATER COOLER WITH RO

Providing and fixing S.S. water cooler of 80ltr storage capacity with 60ltr per hr. cooling capacity. Including inbuilt R.O. Plant consisting of considering the inbuilt booster pump, dry run protection, water purification filters, piping, isolation valves, instruments supports, etc. complete & Medium Penetration UV. Including all Inter connection piping and valve all comp. System as per drinking water IS standard requirement, it is recommended to provide blending system of water at attain TDS level between 250-300 ppm. The supplier has to also supply and installation of SS-316 storage tank - 80 ltr. capacity.

Material:

The water cooler shall be suitable for operation on 230 V +/- 10% , 50 Hz. single phase AC supply with hermetically sealed type suction cooled compressor with overload protection conforming to IS :-10617(part I) : 1983 with amendment no 1&2.

Tank:

Tank shall be fabricated from SS 316 as per ISI 304 and shall be made by electrically seam welded lap joints with PUF insulation, with required number of Taps. Use of lead soldering material for sealing the joints of water tank is not permitted. Water tank cover and lid bottom shall be made of 1.25 mm aluminium sheet duly anodized / epoxy painted / high

TECHNICAL SPECIFICATION

Impact polystyrene (HIP) of 1.5 mm thickness. Positive locking of the lead is to be provided (lock with two keys). A drain valve at the bottom of the storage tank to be provided to draw out water while cleaning.

Cabinet (Body):

The cabinet of the water cooler shall be made of SS 316. The front panel, below the water outlets in the storage type water coolers shall be made of stainless steel. The drain pan for storage type water coolers shall be made of stainless steel. The bottom pedestal shall be made of stainless steel. Pedestal shall have a minimum ground clearance of 100 mm for ease of cleaning. Pedestal shall be strong enough to withstand weight with storage tank full and shall be reinforced to prevent skewing. The body shall be held securely with the pedestal with stainless steel nuts and bolts. The drain size should be 25 mm or above. In case water outlets are provided on three sides then all the three lower panels should be made of aluminium sheet or stainless steel sheet.

The mild steel components used in the manufacture of the cabinet shall be individually degreased, pickled, scrubbed and rinsed to remove grease, rust, scale or any other foreign elements. Immediately after pickling the MS parts shall be given phosphate treatment. The components along with the front panels shall then be given a primer coat with a finish coat of stove with a finish coat of stove enamel paint. The finish shall be smooth and uniform with hard tough film of the enamel adhering to the surface. The finish shall be free from all the visible defects and shall not chip when tapped lightly with a dull pointed instrument. Alternatively method of corrosion protection like plastic powder coating, electrostatic painting shall be permitted.

Refrigeration coils to be fully soldered to the outside of the tank for good thermal contact and not merely tack welded.

There shall not be any gap between water tank cover (mask) and water tank to prevent rodent/ insect/ dust entry.

Water tank overflow should be adequately covered with strainer such as wire mesh etc. to avoid rodent/ insect/ dust entry.

Condenser Fan Motor:

The condenser fan motor shall be capacitor start and capacitor run (CSR) or permanently split capacitor (PSC) or alternatively permanently lubricated motor may be provided.

Thermostat:

The thermostat shall conform to IS: 11338-1985. The position of the thermostat shall be adjustable through a rotary switch mounted on the front or side panels. Min and max of the thermostat setting shall be from 0 degree Celsius and 25 degree Celsius which shall be marked.

Method of Construction:

The water cooler shall be fixed at designated place or as directed by the DTA, duly connected with inlet and drain by leak proof joints. The water cooler is to be erected on stand and tested.

TECHNICAL SPECIFICATION

Mode of Measurement: Executed quantity shall be counted on number basis. (i.e. each)

UV Drinking Water

Model Name	Data to be filled by Contractor
Flow Rate & QTY	
UV Dose	
UV Transmission	
Voltage	
Maximum Power Consumption	
Number of Lamps	
Rating	
MOC	
Max. Lamp Cable Length	
MOC	
End Connections (ASA ISO RF Flanges)	
Max. Operating Pressure	
Max. Operating Temperature	
Max. Sanitization Temperature	
Quartz Jacket MOC	
Lamp Replacement Reminder	
Lamp Failure Indication (with Alarm)	
UV Intensity Meter w/ 4-20mA Output	
Automatic Wiper System	
Sanitary TC End Connections	
UV Intensity Meter with IntelliDose	
Nitrogen Purged UV Intensity Sensor (with Isolated Design)	
4-20mA Output Signal	
RS485 / MODBUS Interface	
Built In Data Logging (3,000 records)	
Remote Lamp / On Off (hardwire or MODBUS)	
Control Panel Temperature Control (with automatic over temperature shutoff)	
Reactor Temperature Control (with automatic over temperature shutoff)	
Automatic Wiping on Low UV	
Lamp Replacement Reminder	
Control Panel Safety Interlock Switch	

27.0 BOREWELL DOMESTIC WATER TREATMENT PLANT

Sea-water reverse-osmosis (SWRO) Automatic, domestic water treatment plant comprising of multigrade sand filter, Activated Carbon filter, RO plant etc. according to input water quality/ analysis. The scope shall include interconnection piping, valves, instruments, back wash arrangement, including Raw water inlet pumps a 1working + 1stand by pump set, micron filter, High pressure pump(1W+1S), and all other required pump approved make) the pump set is auto operation, including dry run protection, RO Module, all valve controls, SS 316 interconnecting piping of suction and discharge header, control panel and other necessary cabling works, 2 pole Motor &

TECHNICAL SPECIFICATION

IE3 Efficiency etc. complete the job. Panel mounted PLC based pump controller, IP 55 enclosure, ON-OFF and Trip Indicating lamps in each incomer and outgoing feeders. The PLC shall support MODBUS-IP communication for its compatibility to integrate with 3rd party BAS system. PLC shall authorize Read/Write command via BMS. Earthing, interlocking arrangement, dry run protection, cascade operation, working / standby selection, with provision of remote on/off operation complete as required. The on/off operations for all pumps shall be available on central BMS system. Each incomer and Outgoing feeder should be capable for protection against Overload, Short Circuit and Phase reversal condition and shall be capable to communicate with BMS. Scope shall also include supply, laying, termination of control and power cables of adequate size, and arrangement of cable tray from Pump to Control panel etc. to complete the job. SITC of electronic type low water level controller with LED panel to operate pump (necessary contacts along with minimum one spare contact required), with probe & all control wiring to operate the system automatic/manual & shall prevent the pump from dry running.

Mounting Height : 500mm from the bottom of tank (RAW UG Tank) SITC of electronic type low & high water level controller with LED panel to operate pump (necessary contacts along with minimum one spare contacts required), level controller with operational mode as one pump working at low level, both pumps at high level with a hooter alarm and cut off at dry level with probe & all control wiring to operate the system automatic/manual & shall prevent the pump from dry running.

Mounting Height (Low Level) : 500mm from the bottom of tank (Treated water UG tank)

Mounting Height (High Level) : 3000 mm from the bottom of tank (Treated water UG tank).

All Automatic valve to be Electronic operated. Raw Water Parameters (ppm)/ Borewell Water Parameters: Scope shall also include for borewell all water test parameters for the design of SWRO Plant consider 1.5 times TDS as compared to test report.

Consider TDS: 5000 minimum for designing of RO Plant, Below Treatment scheme is indicative only. If any other treatment is required, to be done by the contractor, all interconnection piping SS 316 only. Treated Water Parameters (PPM) pH : 6.0 - 7.0, Total Dissolved Solids : 100, Total Suspended Solids : Nil, Total Hardness as CaCO₃ : 10

Technical Details WTP FEED PUMPS Capacity per pump - as per vendor, Head -35 mt Approx. Location -Pump Room MOC: SS body with Cl Casing 1 Set = 2 Nos. Pump (1 Working + 1 Standby - cascade operation) Suction head -flooded positive suction Chlorination Dosing System Pump Capacity : 0-6 LPH at 3.5 kg/cm² MOC : PP Quantity : 01 No. Tank Capacity : 100 Ltrs. Tank MOC : HDPE Quantity : 01 No.

MULTI- GRADE PRESSURE SAND FILTER: Quantity : 1 no., M.O.C. : FRP, Flow Rate : as per vendor cum/hr, Filtration Rate: 15 cum/sqmt/hr, Type of Unit: Down Flow, Filter Media : Silica, Pebbles, Gravels And Quartz Sand, Size : As per Vendor, Type of Unit : Vertical Cylindrical, Working Pressure Kg/cm² : 2.5, interconnection Frontal Piping: SS316, Accessories & Instruments : 1. Pressure gage : at inlet & outlet

ACTIVATED CARBON FILTER: Quantity : 1 no., M.O.C. : FRP, Flow Rate : as per vendor cum/hr, Filtration Rate: 15 cum/sqmt/hr, Type of Unit: Down Flow, Filter Media : Activate Carbon, Size : As per Vendor, Type of Unit : Vertical Cylindrical, Working Pressure Kg/cm² : 2.5, interconnection Frontal Piping: SS316, Accessories & Instruments : 1. Pressure gage : at inlet & outlet.

Antiscalant Dosing System for RO: Pump Capacity : 0-6 LPH at 3.5 kg/cm². MOC : PP, Quantity : 01 No., Tank Capacity : 100 Ltrs., Tank MOC : HDPE, Quantity : 01 No.

SMBS Dosing System for RO: Pump Capacity : 0-6 LPH at 3.5 kg/cm². MOC : PP, Quantity : 0 No., Tank Capacity : 100 Ltrs., Tank MOC : HDPE, Quantity : 01 No.

Acid Dosing System for RO Pump Capacity : 0-6 LPH at 3.5 kg/cm². MOC : PP, Quantity : 01 No., Tank Capacity : 100 Ltrs., Tank MOC : HDPE, Quantity : 01 No.

TECHNICAL SPECIFICATION

Micron Cartridge Filter with Auto Dump Valve for RO:- Capacity : as per vendor m³/hr, Housing MOC : SS316, No. Cartridge : 1 Lot MOC PP, Size : 05 Micron, Size Suitable, Quantity : 01 No.

High Pressure Pump With VFD for RO:- Capacity per pump - as per vendor, Head: as per vendor, 1 Set = 2 Nos. Pump (1 Working + 1 Standby - cascade operation), Intermediate High Pressure Pump With VFD for RO: Capacity & head: as per Vendor 1 Set = 2 Nos. Pump (1 Working + 1 Standby - cascade operation), RO System WITH SKID AND ELECTRICAL PLC PANEL AND INSTRUMENT :- No of Unit : 1 No., Feed Flow rate : as per vendor, Permeate Flow rate : as per vendor , Recovery : 80% , Membrane Type: Sea-water reverse-osmosis (SWRO) RO CIP System:- RO CIP Pump : As per vendor, MOC : SS316, RPM : 2900 RPM, No. of RO CIP Pump : 1 No., MCF : 5 Micron, MOC – PP, No of MCF Unit : 1 No., CIP Tank : 500 Liter HDPE,PH Correction Dosing System:- Pump Capacity : 0-6 LPH at 3.5 kg/cm² , MOC : PP , Quantity : 01 No., Tank Capacity : 100 Ltrs., Tank MOC : LLDPE , Quantity : 01 No. Piping:- High Pressure Piping – SS316 , Low Pressure Piping - SS 316, Flow Meter: 1 nos. WTP Feed Pump Discharge header, 1 nos. RO Permeate water, 1 nos. RO Reject water.

28.0 DEWATERING PUMP FOR SUMP DRAIN:

SCOPE

The scope includes Supply, installation, testing & commissioning of Submersible Non-Clog, single stage, single entry pumps connected to TEFC submersible motor for 415 ± 10% volts, 3 phase, 50 cycles A.C. power supply with mechanical seal, pump connector unit with rubber diaphragm and bend, vertical discharge pipe. The pump shall be provided with a lifting devise of pull chain/guide rail. (Pumps suitable to handle solids up to 20 mm size with C.I. body, SS304 shaft, C.I./SS impeller).

Panel mounted microprocessor-based pump controller, IP 55 enclosure, ON-OFF and Trip Indicating lamps in each incomer and outgoing feeders. The PLC shall support MODBUS-IP communication for its compatibility to Integrate with 3rd party BAS system. PLC shall authorize Read/Write command via BMS., Interlocking arrangement, dry run protection, cascade operation, working / standby selection, with provision of remote on/off operation complete as require. The on/off operations for all pumps shall be available on central BMS system. Each incomer and Outgoing feeder should be capable for protection against Overload, earthing, Short Circuit and Phase reversal condition and shall be capable to communicate with BMS. Scope shall also include supply, laying, termination of control and power cables of adequate size, and arrangement of cable tray from Pump to Control panel etc. to complete the job.

SITC of electronic type High, Medium & Low water level controller with LED panel to operate pump (necessary contacts along with minimum one PLC spare contacts required), level controller with operational mode as one pump working at Medium level, both pumps at high level and cut off at dry level with probe & all control wiring to operate the system automatic/manual & shall prevent the pump from dry running.

Set of accessories such as CPVC SCH 80 discharge headers for (working and stand by pump assembly) from sump bottom to Basement ceiling, Cast Iron control valves, Cast Iron non-return valves, pressure gauge of PN 10 etc. complete the job. Pumping system shall be as per GRIHA Norms.

DESIGN REQUIREMENT:

TECHNICAL SPECIFICATION

The total head capacity curve shall be continuously rising towards the shutoff with the highest at shut off.

The pump shall run smooth without undue noise and vibration.

The power rating of the pump motor shall not be less than the power required from zero discharge to zero head.

Pump shall be submersible, single stage and non-clog type.

It shall be suitable for handling turbid water containing stringy materials. The pump shall be designed to handle solids up to 50 mm dia size.

Delivery pipe shall be CPVC SCH 80. The required length of pipes and fittings up to discharge point shall be provided with necessary fittings.

Level switch (mercury/magnetic reed) to stop the pump automatically shall be supplied with the pump. Pump shall have three phase connections.

TECHNICAL DATA SHEET FOR DEWATERING PUMPS

Particular	Data to be filled by Contractor
Pump	
Make	
Type & Model: Non-Clog Submersible pump semi open impeller	
Discharge in cum/hr.	
Head (Meters of WC)	
Number of Pumps	
Total system flow (cum/hr.)	
Shut off Head (Meters of WC)	
Efficiency (%)	
No. of Stages	
Suction End I.D.	
Delivery End I.D.	
Details of N.P.S.H.	
Vibration Isolation Detail	
Skid Details	
Operating Weight	
Overall Dimension (MM)	
Mechanical Seal Detail	
Material	
Pump Housing: Cast Iron, DIN W.-Nr. GG20	
Impeller: Ductile Cast iron, DIN W.-Nr. GCD450	
Impellers Type: Semi Open Impeller	
Motor housing: Cast Iron, DIN W.-Nr. GG20	
All O rings: NBR Rubber	
Rotor shaft: stainless steel	
Type Bearing: Double-row angular contact ball bearing.	

TECHNICAL SPECIFICATION

Particular	Data to be filled by Contractor
Mechanical Seal: Double mechanical is SiC/SiC.	
Free Ball Passage: - 20mm	
Motor	
Make	
Model	
Power Requirement (HP / KW)	
R.P.M.	
No. of pole: 2 poles	
Efficiency class-IE3	
Insulation class-F	
Type of Motor :3 Phase Induction Motor.	
Supply Frequency-50Hz	
Supply voltage-3X380-415V	
Protection sensor- Thermal and moisture sensor	
Control Panel	
Enclosure class-IP 55	
DETAILS OF PLC	
ACCESSORIES & SERVICES REQUIRED	
Companion flanges	
Spare parts required	
Maintenance tools required	
Plant room outside plant room flange	
Suction, delivery valves & header valves: Required, flanged Cast Iron valves with SS internal parts Make : Kirloskar / KSB / AUDCO/ FLOVEL Flanged Ball / Butterfly valve on suction and delivery of each pump & Flanged Non slam, spring operated dual plate type check valve on delivery side of each pump & on header	
Control Panel: PLC With Starter. Also required Finolex / CCI / Gloster make cable from motor to panel	
Level Transmitter: Required for 0-5 mtr. Range and shall be panel mounted and interlocking with pump	
Pressure Gauge: Required at delivery header.	
Gaskets: 'Champion ' make	
Hardware: Zinc coated	

Note:

- 1) M – Denotes material test certificate required.
- 2) Other specifications not mentioned in datasheet, shall be considered as per tender specification.

29.0 AIR TO WATER HEAT PUMP

Air to Water Heat Pump along with heating element of required capacity capable of operation on air to water basis, patented AES energy saving system, time setting, thermostat setting along with storage tank. The Heat Pump System should be based on a open circuit hot water design temperature of 60 °C out of the unit with 20°C

TECHNICAL SPECIFICATION

Input water temperature for operation.

Heat Pump Capacity: As per BOQ

Refrigerant – R407C/ 410/ 134a, Out Put Heating Capacity, COP: 3.6 to 3.8 and power connected load as per manufacture standard.

The unit shall have its own insulated storage capacity of 1000 ltr With PN 10 rating. The unit shall have all electrical and Hydraulic safety devises inbuilt.

Hot Water Inlet/Out let Temp : 20 Deg C / 60 Deg C . item including of Electrical Panel, piping work and 50mm Rock wood Insulation with 26G Aluminum Cladding in all piping. These units shall be completely factory assembled including thematic scroll compressor, air cooled condenser. Heat pump is equipped with microprocessor-based control, safety device, digital display unit, electrical panel, Inbuilt pumping system & Self-cleaning system, Pump Shall have Working + Stand by with Automatic Cascade Operation. The controller shall support MODBUS-IP communication for its compatability to intergrate with 3rd party BAS system. Controller shall authorise Read/Write command via BMS. System should be capable to compensate for frictional losses at lower flows. All alarms should be displayed in the controller. System should be equipped with dry running protection. Indication of all type of faults / on-off status / electrical parameters shall be available on panel and central IBMS monitors. On-off operation for all pumps shall be available on BMS system.

All Pumping system shall be as per GRIHA Norms.

Hot water pressurize storage tank

Scope:

Supplying, erecting and testing of horizontal/ vertical, pressurize Mild steel heavy duty storage tank of 10Bar working pressure, all internal surfaces exposed to water are glass-lined, Perma Glass Ultra coat second-generation glass coating technology prevents corrosion. With replaceable magnesium anode, temperature and pressure valve, with stainless steel spring set 95 degree Celsius, analogue temperature, Copper coil provides prolonged life and maximum heat transfer efficiency. The smart control Electric Expansion Valve (EEV) accurately controls the refrigerant volume to ensure the unit performs to maximum efficiency.

Insulation: Entire tank is surrounded with high density fiber glass insulation to reduce costly heat loss: non- sagging and vermin- proof. To meet ASHRAE 90.1b-1992 standard depth of insulation cavity requires use of remote bulb- type tank temperature control and thermometer.

Cabinet: heavy gauge steel with high quality powder coat paint provides additional insulating quantities for greater energy savings.

LININGS AND COATINGS

Each lining and coating has particular capabilities and limitations. Please consult the factory for recommendations on the uses of linings for specific applications. Thorough investigation on the service life of steel tanks with protective coatings or linings has led to the recommendations of the following linings:

TECHNICAL SPECIFICATION

Glass-lined: These are normally stocked tanks for water storage up to 82°C, with glass lining to prevent corrosion and addition of rust to water. The glass lining was developed over many years of ceramic research for a wide variety of conditions.

Cement : A special formulation of cement provides excellent corrosion protection. Available on 757 Litres and larger sizes. A manhole or hand hole is included for application of cement lining.

Epoxy : The application of specially formulated epoxy makes this lining suitable for cold or hot water storage. A manhole or handhole is included for application of epoxy lining. Available on 757 Litres and larger sizes.

CATHODIC PROTECTION : Glass-lined, cement and epoxy tanks are furnished with anodes designed for maximum protection.

ACCESSORIES: Tanks will be supplied with the fittings located as indicated on the drawings unless specified otherwise. A manhole or handhole is included on cement or epoxy tanks. A manhole or handhole is optional on glass-lined tanks.

suitable for floor mounting, of specified capacity, one inlet with non-return valve, one outlet with dead weight, pressure reducing valve, stop cock; suitable to work on 230/250-V single phase AC Supply, heating element of specified wattage, thermostat, control fusible plug, pilot lamp etc. ISI mark only and marking of S No. and date of erection. (IS 2082). All Support MS Steel epoxy coated Structure for the tanks. Scope shall also include for grouting of the stands in cement concrete.

Material:

Heating Element: Mineral filled / tubular / copper cord & nickel plated, and conforming to IS: 4159, of specified wattage.

Pilot Lamp: A neon gas field indicating lamp shows functioning of heating elements along with thermostat & thermal cut-out.

Thermostat: A Stem type snap action thermostat, which should cut off the electric supply automatically as per setting of temperature & should be ISI mark.

Thermal Cut-out: In case of thermostat failure this cutout should cut off the electric supply automatically and should restart only on pressing the reset knob.

Pressure Release Valve: If pressure exceeds above 50 psi, it should release the pressure & should be fitted on the inlet pipe.

Dead weight: It will operate when pressure in inside tank increase beyond specified limit.

Fusible plug: Cast aluminium body with threading, and hole for plug with fusible metal. The metal shall be fused, only all the other safeties fails & at high pressure

Hardware: 100x10 mm grouting bolts, MS washers, nuts, etc.

TECHNICAL SPECIFICATION

Wall Fasteners: 100x10 mm with vertical cuts, and pin at the centre, washer and nut etc., made of MS. (Similar to Anchor bolt fastener)

30.0 HOT WATER RECIRCULATION PUMPS:

Scope:

The specification covers Supply, installation, testing & commissioning of online Thermostat with Timer based circulation booster pumps at Terrace Level with Require head directly coupled with the motor with SS casing, SS impeller, SS shaft and driven by 415 V AC, 3 phase, 50 Hz. motor running at 2900 RPM speed and shall be supplied with all accessories viz., base plate, coupling, motor, Antivibration Pad, 2 pole Motor & IE3 Efficiency etc. complete. Panel mounted microprocessor-based pump controller, IP 55 enclosure, shall include the thermostat, required sensors and the timer control panel, ON-OFF and Trip Indicating lamps in each incomer and outgoing feeders. The PLC shall support MODBUS-IP communication for its compatibility to integrate with 3rd party BAS system. PLC shall authorize Read/Write command via BMS., earthing, interlocking arrangement, dry running protection, cascade operation, working / standby selection, with provision of remote on/off operation complete as require. The on/off operations for all pumps shall be available on central BMS system. Each incomer and Outgoing feeder should be capable for protection against Overload, Short Circuit and Phase reversal condition and shall be capable to communicate with BMS. Scope shall also include supply, laying, termination of power cables of adequate size, and arrangement of cable tray from Pump to Control panel etc. to complete the job. Set of accessories such as GI C Class headers of suction and discharge for (working and Assist by pump assembly) with CED Coating, Cast Iron control valves, Cast Iron non return valves, Thermostate, Timer operation, pressure gauge of PN 10 etc. complete the job. Require complete company fitted ready-to-connect packaged system. Pumping system shall be as per GRIHA Norms.

The items/quantities shall be measured and paid upon completion of the linked milestone as per schedule 10 for the respective item.

Construction features:

The major components of the system shall be as follows:

A. PUMP:

Inline vertical multistage pump shall be provided. Variable frequency drive shall be provided with one of the installed pump – if specified in Schedule of quantity.

The pump – motor set and shall be suitable for 3 Ph., 415 V, 50 Hz. AC power supply and having 2900 RPM speed. The pump shall be installed with isolation butterfly valve, non return valve, etc. The detailed specification for pump & motor is as below:

Horizontal Multi stage Pumps

Codes & Standards :

TECHNICAL SPECIFICATION

The design and manufacture of the pump shall comply with all currently applicable statutes, regulations and safety codes in the locality where the equipment will be installed.

Design Features:

The pump shall be capable of developing required total head at rated capacity. Impeller shall be closed type and shall be dynamically balanced. The pump shall have non overloading characteristics.

i. Constructional Features:

The casing shall be of rigid construction and shall have side suction and side delivery in case of inline pump and side suction and central delivery in case of submersible centrifugal pump.

The pump shall have very small length suction and delivery pipe connections which will result in minimum friction loss.

Impeller shall be of one piece and shall be of SS CF8 M.

The shaft shall be of S.S. and its surface shall be properly finished.

Shaft sleeves shall be provided to protect shaft from any damage.

Bearing shall be ball or roller type.

Mechanical seal shall be provided to avoid any leakage.

ii. Inspection & Testing:

The pump shall be offered for visual inspection before dispatch.

Material test certificates for the various pump components shall be furnished for purchaser's approval.

Hydrostatic test shall be carried out at 1.5 times the maximum discharge pressure.

All the tests shall be witnessed by purchaser.

iii. Drawings:

Following drawings shall be furnished by the Contractor:

Overall dimensional drawing.

Cross-sectional drawings with all dimension (vertical and horizontal) with Bill of Material and Material of Construction.

iv. Accessories:

TECHNICAL SPECIFICATION

The pump shall be provided with all accessories such as base plate, foundation bolts, strainer, pressure gauge, etc. All accessories required for proper and safe operation shall be furnished with the pumps.

v. Pressure transducer:

The system shall be installed with the pressure transducer which shall be set at predefernined pressure to automatically control the pump operation.

vi. Manifolds, Valves, Base frame & Accessories

Suction and Delivery manifolds in Hot Dip Galvanized steel. (80-110micron) DIN standard flange connections.

One non-return valve and Isolating valves for each pump is provided in delivery side and one isolating valve is provided in suction side.

Manifolds and valves are suitable for 16bar pressure rating.

Pumps should be mounted on the common base frame.

Base frame and panel side support is in Galvanized steel.

Suitable range of pressure gauges and pressure transmitter should be connected at the discharge manifolds.

Vibration dampening pad for minimize the noise and vibration in the system.

Concrete foundation as per manufacturer recommendation. (1.5 times X the weight of the Pumping system).

TECHNICAL DATA SHEET pumping system:

Particular	Data to be filled by Contractor
Pump	
Make	
Type & Model: Horizontal Multistage	
Discharge in cum/hr	
Head (Meters of WC)	
Number of Pumps	
Total system flow (cum/hr)	
Shut off Head (Meters of WC)	
Efficiency (%)	
No. of Stages	
Suction End I.D.	
Delivery End I.D.	
Details of N.P.S.H.	
Vibration Isolation Detail	
Skid Details	
Operating Weight	
Overall Dimension (MM)	
Mechanical Seal Detail	
Material	
Pump Head - Cast Iron	
Pump Base- Cast Iron	

TECHNICAL SPECIFICATION

Particular	Data to be filled by Contractor
Impeller-SS 304	
Chamber-SS 304	
Shaft-SS316	
Motor stool-Cast Iron	
Shaft seal Cartridge type(SiC/Carbon)	
Rubber parts-EPDM	
Motor	
Make	
Model	
Power Requirement (HP / KW)	
R.P.M.	
No. of pole: 2 pole	
Efficiency class-IE3	
Insulation class-F	
Enclosure class-IP 55	
Supply Frequency-50Hz	
Supply voltage-3X380-415V	
Built in Thermistor-PTC	
Control Panel	
Enclosure class-IP 55	
DETAILS OF PLC	
DETAILS OF VFD	
Pressure Vessel	
Make	
Model Number	
Material of construction (Vessel/Bladder)	
Dimension	
Overall capacity	
Cut-in/Cut-out setting	
Capacity at specified cut-in/cut-out	
Overall dimension of skid mounted system	
Weight (Static/Dynamic)	
ACCESSORIES & SERVICES REQUIRED	
Base Plate	
Foundation bolts	
Companion flanges	
Spare parts required	
Maintenance tools required	
Cut in pressure	
Cut off pressure	
Plant room suction matching flange & outside plant room flange	
Suction & delivery piping: MS. hot dipped galvanized, Class 'C' with CED Coated	
Suction, delivery valves & header valves: Required, flanged Cast Iron valves with SS internal parts Make : Kirloskar / KSB / AUDCO/ FLOVEL	

TECHNICAL SPECIFICATION

Particular	Data to be filled by Contractor
Flanged Ball / Butterfly valve on suction and delivery of each pump & Flanged Non slam, spring operated dual plate type check valve on delivery side of each pump & on header	
Control Panel: With Starter. One pump of similar rating shall have VFD Required with all protections & sequential timer for main pumps Also required Finolex / CCI / Gloster make cable from motor to panel	
Level Transmitter: Required for 0-5 mtr. Range and shall be panel mounted and interlocking with pump	
Pressure Transmitter	
Pressure Gauge: Required at delivery header.	
Gaskets: 'Champion ' make	
Hardware: Zinc coated	

31.0 TUBE WELL WATER TREATMENT PLANT:

Scope:

Supply installation, testing and commissioning of domestic water treatment plant comprising of multigrade sand filter, Activated Carbon filter, Softener etc. according to input water quality/analysis The scope shall include interconnection piping, valves, instruments, back wash arrangement, including Raw water Inlet pumps a 1 working + 1 stand by pump set, and all other required pump Grundfos or ITT lowara make) the pump set is auto operation, including dry run protection, Required Gun Metal Ball Valve & Cast Iron Butterfly valve, interconnecting CPVC piping of suction and discharge header, control pannel and other necessary cabling works, 2 pole Motor & IE3 Efficiency etc. complete the job. Panel mounted PLC based pump controller, IP 55 enclosure, ON-OFF and Trip Indicating lamps in each incomer and outgoing feeders, The PLC shall support MODBUS-IP communication for its compatability to intergrate with 3rd party BAS system. PLC shall authorise Read/Write command via BMS. earthing, interlocking arrangement, dry run protection, cascade operation, working / standby selection, with provision of remote on/off operation complete as require. The on/off operations for all pumps shall be available on central BMS system. Each incomer and Outgoing feeder should be capable for protection against Overload, Short Circuit and Phase reversal condition and shall be capable to communicate with BMS. Scope shall also include supply, laying, termination of control and power cables of adequate size, and arrangement of cable tray from Pump to Control panel etc. to complete the job.

SITC of electronic type low water level controller with LED panel to operate pump (necessary contacts along with minium one spare contacts required), with probe & all control wiring to operate the system automatic/manual & shall prevent the pump from dry running. Mounting Height : 500mm from the bottom of tank (RAW UG Tank).

Raw Water Parameters (ppm) / Borewell Water Parameters: Scope shall also

TECHNICAL SPECIFICATION

Include for All borewell all water test parameters (as per Specification) for The designing of Water Treatment Plant.

All Automatic valve to be Electronic operated.

All Pumping system shall be as per GRIHA Norms.

Chlorination Dosing System:

The scope includes supply installation testing & commissioning of Chlorination dosing pump, chlorine & tank. This system shall be PID control,

Multi grade filter:

The scope includes supply installation testing & commissioning of Multi Grade Filter, Interconnection and other piping, solenoid valve, non return valve, fittings, Air release valve, etc. The Filter shall have auto back wash operation.

Pipe shall be CPVC sch 80. The required length of pipes and fittings up to discharge point shall be provided with necessary fittings.

Activated carbon filter:

The outflow of Multi Grade Filter will further be treated through Activated carbon filter to remove odour & taste.

The scope includes supply installation testing & commissioning of Activated Carbon Filter, interconnection and other piping, solenoid valve, non-return valve, fittings, Air release valve, etc. The Filter shall have auto back wash operation.

Pipe shall be CPVC sch 80. The required length of pipes and fittings up to discharge point shall be provided with necessary fittings.

Softener:

Further, the hardness will be removed by softener.

The scope includes supply installation testing & commissioning of Softener, brine tank , interconnection and other piping, solenoid valve, non-return valve, fittings, Air release valve, etc. The softener shall have automatic regeneration.

Pipe shall be CPVC sch 80. The required length of pipes and fittings up to discharge point shall be provided with necessary fittings.

Interconnecting CPVC SCH 80 piping & instrumentation:

Scope:

The scope includes supply installation testing & commissioning of interconnection piping CPVC SCH 80 & fitting, interconnection and other piping, valve, non-return valve, fittings, Air release valve, etc.

TECHNICAL SPECIFICATION

Sr No.	Description	Tender Requirement	Data to be filled by vendor
	Technical Details: -		
A	MGF & ACF Treatment Plant		
1	Filter feed pump		
	Quantity	2(1W + 1S)	
	Flow	23 m3/hr	
	Make	As per Approved Make List	
	Head	30-35M	
	Type	Horizontal Centrifugal	
	MOC	SS 316	
	Panel IP	IP 55	
	PLC	Vendor to be provided details	
2	Flow Meter at inlet & outlet		
	Quantity	2 Nos.	
	Type	Electromagnetic	
	Size	as per Vendor	
	Make	As per Approved Make List	
3	Multigrade Sand Filter		
	Quantity	1 No.	
	Design Code	IS-2825	
	Flow	23 m3/hr	
	Filtration Rate:	18 cum/sqmt/hr	
	Backwash flow rate:	as per Vendor	
	Size	1100 MM Dia	
	Media	as per vendpr	
	Media Qty.	As per Vendor	
	Media Depth	As per Vendor	
	Shell thickness	As per Vendor	
	Dished end thickness	As per Vendor	
	Bed plate thickness	As per Vendor	
	Top nozzle for chlorine sanitation	Provided with valve.	
	Frontal Pipe	GI C Class with painting two coats of approved shade of enamel paint over a coat of approved primer.	
	Valve	SS Disc, EPDM Seat	
	Side manhole for media removal.	Required	
	MOC	MSEP (Epoxy Coated inside & Outside).	
	Design Pressure	5.0 kg/cm ²	
	Working Pressure	3.5 kg/cm ²	
	Make	Ion Exchange/Thermax/Aakar Engineers/Equivalent	
4	Activated Carbon filter		

TECHNICAL SPECIFICATION

Sr No.	Description	Tender Requirement	Data to be filled by vendor
	Quantity	1 No	
	Design Code	IS-2825	
	Flow	23 m ³ /hr	
	Filtration Rate:	18 cum/sqmt/hr	
	Backwash flow rate	as per vendor	
	Size	1100 MM Dia	
	Media	as per vendor	
	Media Qty.	As per Vendor	
	Media Depth	As per Vendor	
	Shell thickness	As per Vendor	
	Dished end thickness	As per Vendor	
	Bed plate thickness	As per Vendor	
	Frontal Pipe	GI C Class with painting two coats of approved shade of enamel paint over a coat of approved primer.	
	Valve	SS Disc, EPDM Seat	
	Side manhole for media removal,	Required	
	Sampling Cock	Required at Inlet & Outlet	
	MOC	MSEP (Epoxy Coated inside & Outside).	
	Design Pressure	5.0 kg/cm ²	
	Working Pressure	3.5 kg/cm ²	
	Make	Ion Exchange/Thermax/Aakar Engineers/Equivalent	
5	Softener		
1.0	MAKE	Ion Exchange/Thermax/Aakar Engineers/Equivalent	
2.0	Model	Pl. Furnish	
3.0	Quantity	As per BOQ	
4.0	Capacity	As per BOQ	
5.0	Operation	Automatic	
6.0	Type of Unit	Down Flow	
7.0	Size	As per BOQ	
8.0	M.O.C	MSEP	
9.0	Size of Valve	As per Vendor	
10.0	Size of Piping	As per Vendor	
11.0	Flow Rate	As per BOQ	
12.0	Media Qty	As per Vendor	
13.0	OBR	As per BOQ	
14.0	Brine tank capacity	As per Vendor	
15.0	Brine tank MOC	MSFRP	
16.0	Working Pressure	Maxi : 3.5 / Mini : 3.0 Kg/cm ²	
17.0	Regeneration	Manual	
18.0	Agitator	100 rpm	

TECHNICAL SPECIFICATION

Sr No.	Description	Tender Requirement	Data to be filled by vendor
19.0	Agitator Motor	As per vendor	
20.0	Agitator MOC	MSRL	
21.0	ventury	As per vendor design	
6	Pressure gauge		
	Quantity	1 lot	
7	TDS/Conductivity meter with Local display & Transmitter (ACF OUTLET)		
	Quantity	1 nos.	
	Type	Line Mounted	
	MAKE	As per Approved Make List	
8	Piping and Valves work		
	Quantity	1 lot	
	Piping MOC	GI C Class with painting two coats of approved shade of enamel paint over a coat of approved primer.	
	Line Sizes	As per Vendor	

32.0 TUBE WELL SUBMERSIBLE PUMP:

Submersible pump set generally comprises of the following:

- a) Pump
- b) Motor
- c) Non Return Valve
- d) Cable & Cable guards

PUMP ASSEMBLY:

This comprises of suction strainer, bowl, shaft, impeller, bearing, discharge casing etc.

Stator winding will be cooled by surrounding water.

Impeller shall be enclosed type and it shall be dynamically balanced.

Pump shaft shall be guided through bearings.

Surface finish of shaft shall be 0.75 milli micron.

The inlet passage of the suction casing shall be streamlined to avoid eddies.

Pump casing shall have provision for securing cable.

Cable guards shall be provided over the cable to prevent any damage.

MOTOR:

TECHNICAL SPECIFICATION

Motor shall be squirrel cage, water filled, induction, wet type and shall conform to IS 9283: 1979.

Stator winding will be cooled by surrounding water.

A seal ring and sand slings will be provided to prevent entry of water and sandy particles to the stator tube.

A pressure equalising rubber diaphragm shall be provided in the lower part of the motor to absorb the expansion of water which will take place due to heat dissipation.

A thrust plate shall be provided to take axial thrust of the pump and rotor.

NON RETURN VALVE:

NRV shall be provided to protect piping system in the case of water hammer which shall occur due to power failure.

CABLE:

Cable shall conform to 4.4 of IS 9283 : 1979. This cable shall run along the pump casing. The cable shall be protected by cable guard. The cable shall be PVC Insulated copper flat cable.

BORECAP:

It shall be manufactured from M.S. sheet.

CABLEGUARD:

Every pipe joint, flat cable shall be bind with nylon core of (1/16").

CLAMP:

Clamps shall be provided for column pipe and shall be made of heavy duty MS flat

Supplying & erecting approved make Automatic liquid level controller 6A.as per instruction of Engineer in charge on site complete with wiring connection, with copper conductor from pump to tank to monitor the liquid level and passes the signal to tube well motor for on/off operation

TESTS:

VISUAL INSPECTION:

A pump shall be offered for a visual inspection to the client before despatch.

HYDROSTATIC TEST:

This test shall be carried out at 1.5 times the maximum discharge pressure for an individual casing or for whole assembled pump. The pump shall be tested for operating head range.

TECHNICAL SPECIFICATION

DRAWINGS TO BE FURNISHED BY VENDOR:

- 1) Performance curves.
- 2) Overall dimensional drawing
- 3) Cross-sectional drawing with Bill of Material and material of construction.

PAINTING AND MARKING:

The pump shall be painted with epoxy paint and property marked with:

- 1) Manufacturer's Name
- 2) Model No.
- 3) Motor rating
- 4) Discharge at duty point
- 5) Head at duty point
- 6) Overall efficiency at duty point
- 7) Rated speed
- 8) Rated Voltage
- 9) Frequency
- 10) Delivery size

Contractor has to submit the report with the following data :

Static water level of the bore well

Pumping level of bore well

Discharge of Pump in m³/hr.

Ampere meter, Volt meter, Power meter, etc. reading for 4 hour working of submersible pump.

GUARANTEE:

The manufacturer shall give guaranteed minimum efficiency at duty point.

The pump shall be guaranteed by the manufacturer against any defects and workmanship for a period of at least 12 months from the date of commissioning, whichever is less.

SUBMERSIBLE PUMP (DOMESTIC WATER)

Sr. No.	ITEM DESCRIPTION	DATA
1.0	Type of Pump	Submersible Fixed Type
2.0	Mfg. Standard	IS 8034: 1989 with its latest revision
3.0	Fluid	Bore well Water
4.0	PH	As per water test report

TECHNICAL SPECIFICATION

Sr. No.	ITEM DESCRIPTION	DATA
5.0	Sp. Gravity	1.0
6.0	Temperature	30 deg. Cent.
7.0	Solid Handling Capacity	Fine Sand Handling
8.0	Pump Detail	
8.1	Quantity	1 No. For Domestic water
8.2	Capacity in Ltr./hr.	As per BOQ
8.3	Head in mtrs.	As per BOQ
8.4	Operating Condition	Continuous
8.5	Rated Speed	2900 RPM
8.6	No. of stages	Minimum preferred
8.7	Method of Lubrication	Self
8.8	Impeller	Semi Open/Enclosed
8.9	Type of seal	Mechanical
8.10	Type of connection	Flanged
8.11	Maximum Outside Diameter	As per mfg. standard
8.12	Overall efficiency at duty point	•
8.13	Foot Valve	Required (One side threaded, other side column pipe flange)
9.0	Motor	
9.1	Rating	•
9.2	Type	Wet Submersible Squirrel Cage Induction
9.3	Mfg. Standard	IS 9283 : 1985 with its latest revision
9.4	Supply Condition	3 Phase, 415 Volts $\pm 10\%$, 50 Hz, $\pm 5\%$, Combined $\pm 10\%$
9.5	Connection	Directly coupled
9.6	Starter	Star / Delta
9.7	Minimum reserve power required at duty point	15%
10.0	Material of Construction	
10.1	Impeller	Bronze IS 318 Gr. LTB2
10.2	Shaft	S.S. AISI 410 or ASTM A276
10.3	Suction Strainer	SS 304
10.4	Pump casing	C.I FG 200 with 1.5 to 2%
10.5	Bearing Bush	Leaded Tin Bronze
10.6	Thrust plate	Bronze
10.7	Bearing Sleeve	S.S. 316
11.0	Cable	
11.1	Standard	IS9283: 1979 Clause 4.4
11.2	Cable type	3 Core water proof flat

TECHNICAL SPECIFICATION

Sr. No.	ITEM DESCRIPTION	DATA
		copper cable
12.0	Drawings:	1) Performance curves 2) Overall dimensional drawing

Note : "*" denotes information's to be provided by the bidder

33.0 INSTALLATION OF ENGINEERED SUPPORT SYSTEM

Plumbing pipe support from RCC slab

The Plumbing Pipes should be simply supported by Split Clamps. Split Clamps should be pre-galvanised and should have a two-piece arrangement with ribbing reinforced clamp body and two captive tightening bolts, secured with loss washers for non-slipping high load bearing capacity.

The Split clamp should have an EPDM rubber lining which will prevent the direct contact of Pipe with the steel. The rubber lining should have the capacity to reduce the structure borne noise vibration to up to 18 dB and 22dB for waster water pipe.

Pipe clamp should be as per DIN 3576 if support for metal pipe. The support installation should be as per international plumbing code. The Clamp should have the temperature capacity of -50 degree Celsius to +150 degrees Celsius.

In the case of multiple pipes, the supporting arrangement should be made using support channel made up of cold rolled steel of quality DX51 or greater and as per EC3(Eurocode 3) or DIN EN 1993-1-1

The Support channel should be pre galvanised with minimum GSM of 275 and should have universal mounting slot on the front of the rail for accurate positioning of fasteners and system compatible round and long holes on back of the rail.

The Mounting according to static requirements should undertake into account the manufacturer's documents and should be monitored according to RAL - GZ 655-C

The Threaded Rods used for the suspension of the Pipe should be made up of partially annealed medium carbon steel of grade 4.8 strength class and as per DIN 976 standard.

The Drop-In anchors used for the suspension of the rods should be ETA (EUROPEAN TECHNICAL APPROVAL) with CE mark for cracked and un-cracked concrete.

It should be divided into four expansion segments for uniform pressing force distribution in the borehole.

The load bearing capacity for the selection of the split clamp for suitable size of the pipe should be provided by the contractor to the consultant for verification.

TECHNICAL SPECIFICATION

Nomin al Pipe Dia (mm)	Maximum Support Spacing (m)				Nomin al Pipe Dia (mm)	Maximum Support Spacing (m)			
	UPVC Pipe		POLYETHYLENE PIPE Class D, E, 6, 7			UPVC Pipe		POLYETHYLENE PIPE Class D, E, 6, 7	
	Horizont al	Vertic al	Horizont al	Vertic al		Horizont al	Vertic al	Horizont al	Vertic al
Upto 10	-	0,6	0,3	0,5	65	1,2	1,4	0,6	0,9
15	-	0,6	0,4	0,6	80	1,4	1,5	0,6	0,9
20	-	0,7	0,4	0,6	100	1,5	1,7	0,7	1,1
25	-	0,8	0,4	0,6	125	1,7	1,9	-	-
32	-	0,8	0,5	0,7	150	1,8	2,1	-	-
40	-	0,9	0,5	0,7	175	2,0	2,3	-	-
50	1,1	1,2	0,6	0,9	200	2,1	2,5	-	-

Fig P. Typical Arrangement for plumbing pipe support from RCC slab

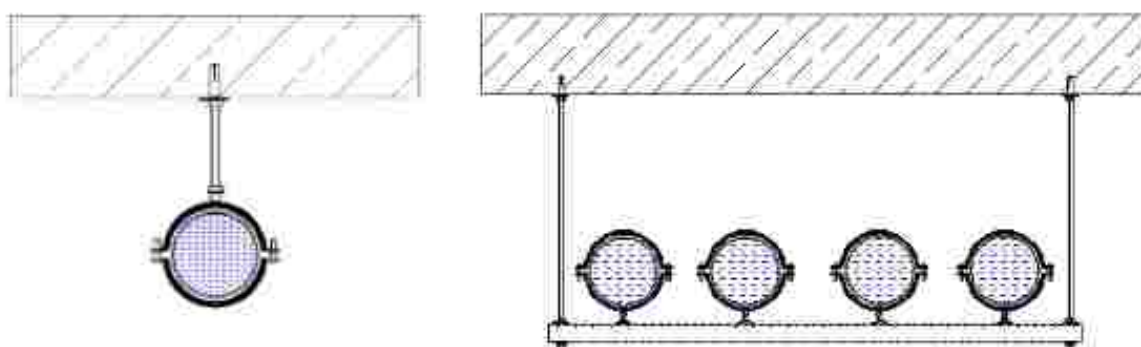

Plumbing pipe support from PEB Structure

The Plumbing Pipes should be simply supported by Split Clamps.

Split Clamps should be pre-galvanised and should have a two-piece arrangement with ribbing reinforced clamp body and two captive tightening bolts, secured with loss washers for non-slipping high load bearing capacity.

The Split clamp should have an EPDM rubber lining which will prevent the direct contact of Pipe with the steel. The rubber lining should have the capacity to reduce the structure borne noise vibration to up to 18 dB and 22dB for waster water pipe.

Pipe clamp should be as per DIN 3576 if support for metal pipe.

The support installation should be as per International plumbing code.

The Clamp should have the temperature capacity of -50 degree Celsius to +150 degrees Celsius.

In the case of multiple pipes, the supporting arrangement should be made using support channel made up of cold rolled steel of quality DX51 or greater and as per EC3(Eurocode 3) or DIN EN 1993-1-1

The Support channel should be pre galvanised with minimum GSM of 275 and should have universal mounting slot on the front of the rail for accurate positioning of fasteners and system compatible round and long holes on back of the rail.

The Mounting according to static requirements should undertake into account the

TECHNICAL SPECIFICATION

manufacturer's documents and should be monitored according to RAL - GZ 655-C

The Threaded Rods used for the suspension of the Pipe should be made up of partially annealed medium carbon steel of grade 4.8 strength class and as per DIN 976 standard.

For parallel to beam application,

The Girder cleat for attachment of support channel to steel girder

Girder cleat should be Vds approved.

For perpendicular to beam application

The Girder clamp for suspension of threaded pins and threaded rods for support channels.

Girder clamps should be FM and Vds Approved.

The load bearing capacity for the selection of the split clamp for suitable size of the pipe should be provided by the contractor to the consultant for verification.

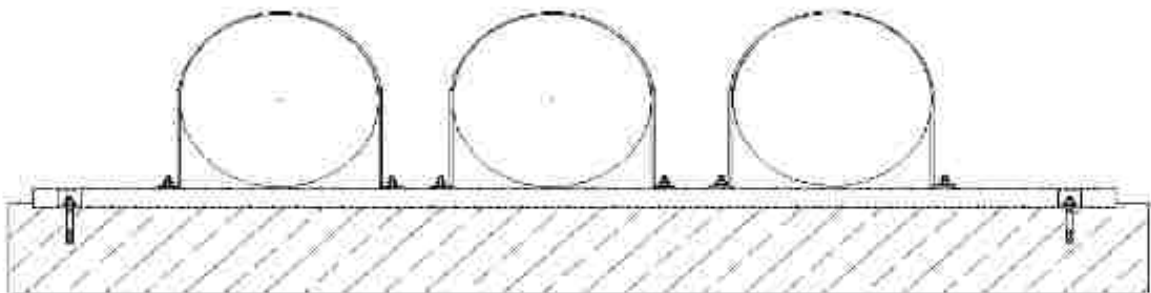

Nomin al Pipe Dia (mm)	Maximum Support Spacing (m)				Nomin al Pipe Dia (mm)	Maximum Support Spacing (m)			
	UPVC Pipe		POLYETHYLENE PIPE Class D, E,6,7			UPVC Pipe		POLYETHYLENE PIPE Class D, E,6,7	
	Horizont al	Vertic al	Horizont al	Vertic al		Horizont al	Vertic al	Horizont al	Vertic al
Upto 10	-	0.6	0.3	0.5	65	1.2	1.4	0.6	0.9
15	-	0.6	0.4	0.6	80	1.4	1.5	0.6	0.9
20	-	0.7	0.4	0.6	100	1.5	1.7	0.7	1.1
25	-	0.8	0.4	0.6	125	1.7	1.9	-	-
32	-	0.8	0.5	0.7	150	1.8	2.1	-	-
40	-	0.9	0.5	0.7	175	2.0	2.3	-	-
50	1.1	1.2	0.6	0.9	200	2.1	2.5	-	-

TECHNICAL SPECIFICATION

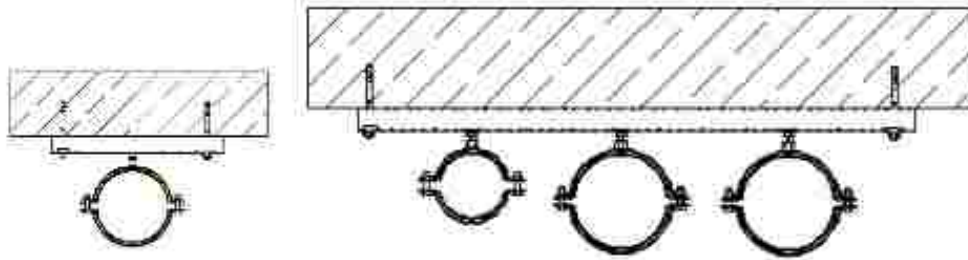

Plumbing pipe support from Terrace

The Plumbing Pipes should be simply supported by Split Clamps.

Split Clamps should be pre-galvanised and should have a two-piece arrangement with ribbing reinforced clamp body and two captive tightening bolts, secured with loss washers for non-slipping high load bearing capacity.

The Split clamp should have an EPDM rubber lining which will prevent the direct contact of Pipe with the steel. The rubber lining should have the capacity to reduce the structure borne noise vibration to up to 18 dB and 22dB for waster water pipe. Pipe clamp should be as per DIN 3576 if support for metal pipe.

The support installation should be as per international plumbing code.

The Clamp should have the temperature capacity of -50 degree Celsius to +150 degree Celsius.

In the case of multiple pipes, the supporting arrangement should be made using support channel made up of cold rolled steel of quality DX51 or greater and as per EC3(Eurocode 3) or DIN EN 1993-1-1

The Support channel should be pre galvanised with minimum GSM of 275 and should have universal mounting slot on the front of the rail for accurate positioning of fasteners and system compatible round and long holes on back of the rail.

The Mounting according to static requirements should undertake into account the manufacturer's documents and should be monitored according to RAL - GZ 655-C.

In the case of pipe sizes beyond 4" for the steel pipe, it should be clamped with either a Split pipe clamp with all round welded nut or by using a Pipe strap.

The Threaded Rods used for the fixing Pipe clamp with channel that should be made up of partially annealed medium carbon steel of grade 4.8 strength class and as per DIN 976 standard.

The Drop-in anchors or stud anchor used for the channel fixing with terrace that should be ETA (EUROPEAN TECHNICAL APPROVAL) with CE mark for cracked and un-cracked concrete.

It should be divided into four expansion segments for uniform pressing force distribution in the borehole.

The load bearing capacity for the selection of the split clamp for suitable size of the pipe should be provided by the contractor to the consultant for verification.

TECHNICAL SPECIFICATION

Nominal Pipe Dia (mm)	Maximum Support Spacing (m)				Nominal Pipe Dia (mm)	Maximum Support Spacing (m)			
	UPVC Pipe		POLYETHYLENE PIPE Class D, E, 6, 7			UPVC Pipe		POLYETHYLENE PIPE Class D, E, 6, 7	
	Horizontal	Vertical	Horizontal	Vertical		Horizontal	Vertical	Horizontal	Vertical
Upto 10	-	0.6	0.3	0.5	65	1.2	1.4	0.6	0.9
15	-	0.6	0.4	0.6	80	1.4	1.5	0.6	0.9
20	-	0.7	0.4	0.6	100	1.5	1.7	0.7	1.1
25	-	0.8	0.4	0.6	125	1.7	1.9	-	-
32	-	0.8	0.5	0.7	150	1.8	2.1	-	-
40	-	0.9	0.5	0.7	175	2.0	2.3	-	-
50	1.1	1.2	0.6	0.9	200	2.1	2.5	-	-

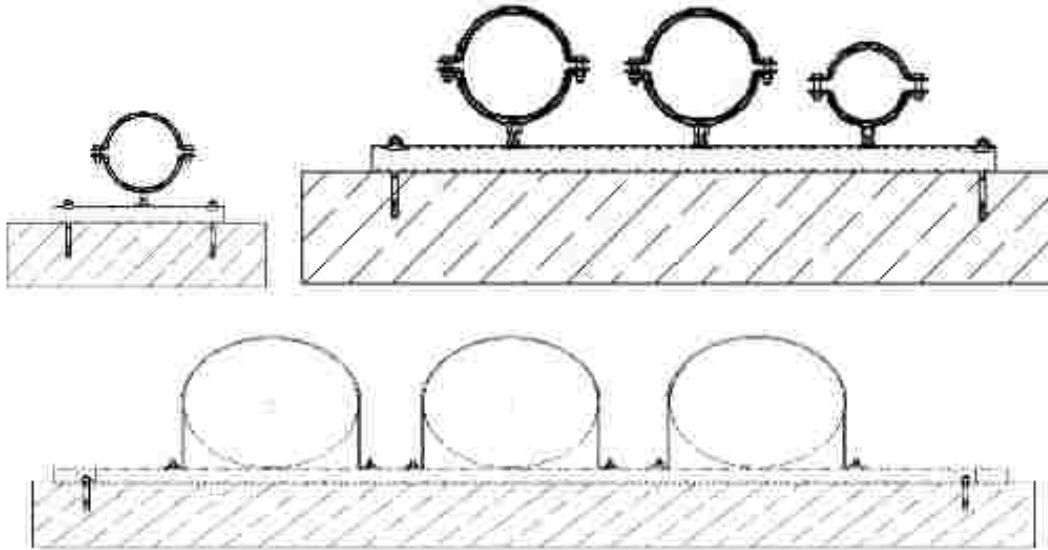

Plumbing pipe support from Wall

The Plumbing Pipes should be simply supported by Split Clamps.

Split Clamps should be pre-galvanised and should have a two-piece arrangement with ribbing reinforced clamp body and two captive tightening bolts, secured with lock washers for non-slipping high load bearing capacity.

The Split clamp should have an EPDM rubber lining which will prevent the direct contact of Pipe with the steel. The rubber lining should have the capacity to reduce the structure borne noise vibration to up to 18 dB.

Pipe clamp should be as per DIN 3576 if support for metal pipe.

The support installation should be as per International plumbing code.

The Clamp should have the temperature capacity of -50 degree Celsius to +150 degree Celsius.

In the case of multiple pipes, the supporting arrangement should be made using support channel made up of cold rolled steel of quality DX51 or greater and as per EC3(Eurocode 3) or DIN EN 1993-1-1

TECHNICAL SPECIFICATION

The Support channel should be pre galvanised with minimum GSM of 275 and should have universal mounting slot on the front of the rail for accurate positioning of fasteners and system compatible round and long holes on back of the rail.

The Mounting according to static requirements should undertake into account the manufacturer's documents and should be monitored according to RAL - GZ 655-C.

In the case of pipe sizes beyond 4" for the steel pipe, it should be clamped with either a Split pipe clamp with all round welded nut or by using a Pipe strap.

The Threaded Rods used for the fixing Pipe clamp with channel that should be made up of partially annealed medium carbon steel of grade 4.8 strength class and as per DIN 976 standard.

The Drop-in anchors or stud anchor used for the channel fixing with terrace that should be ETA (EUROPEAN TECHNICAL APPROVAL) with CE mark for cracked and un-cracked concrete.

It should be divided into four expansion segments for uniform pressing force distribution in the borehole.

The load bearing capacity for the selection of the split clamp for suitable size of the pipe should be provided by the contractor to the consultant for verification.

Nomin al Pipe Dia (mm)	Maximum Support Spacing (m)				Nomin al Pipe Dia (mm)	Maximum Support Spacing (m)			
	UPVC Pipe		Polyethylene Pipe Class D, E, 6, 7			UPVC Pipe		Polyethylene Pipe Class D, E, 6, 7	
	Horizo ntal	Verti cal	Horizon tal	Vertic al		Horizo ntal	Vertic al	Horizon tal	Vertic al
Upto 10	-	0.6	0.3	0.5	65	1.2	1.4	0.6	0.9
15	-	0.6	0.4	0.6	80	1.4	1.5	0.6	0.9
20	-	0.7	0.4	0.6	100	1.5	1.7	0.7	1.1
25	-	0.8	0.4	0.6	125	1.7	1.9	-	-
32	-	0.8	0.5	0.7	150	1.8	2.1	-	-
40	-	0.9	0.5	0.7	175	2.0	2.3	-	-
50	1.1	1.2	0.6	0.9	200	2.1	2.5	-	-

TECHNICAL SPECIFICATION

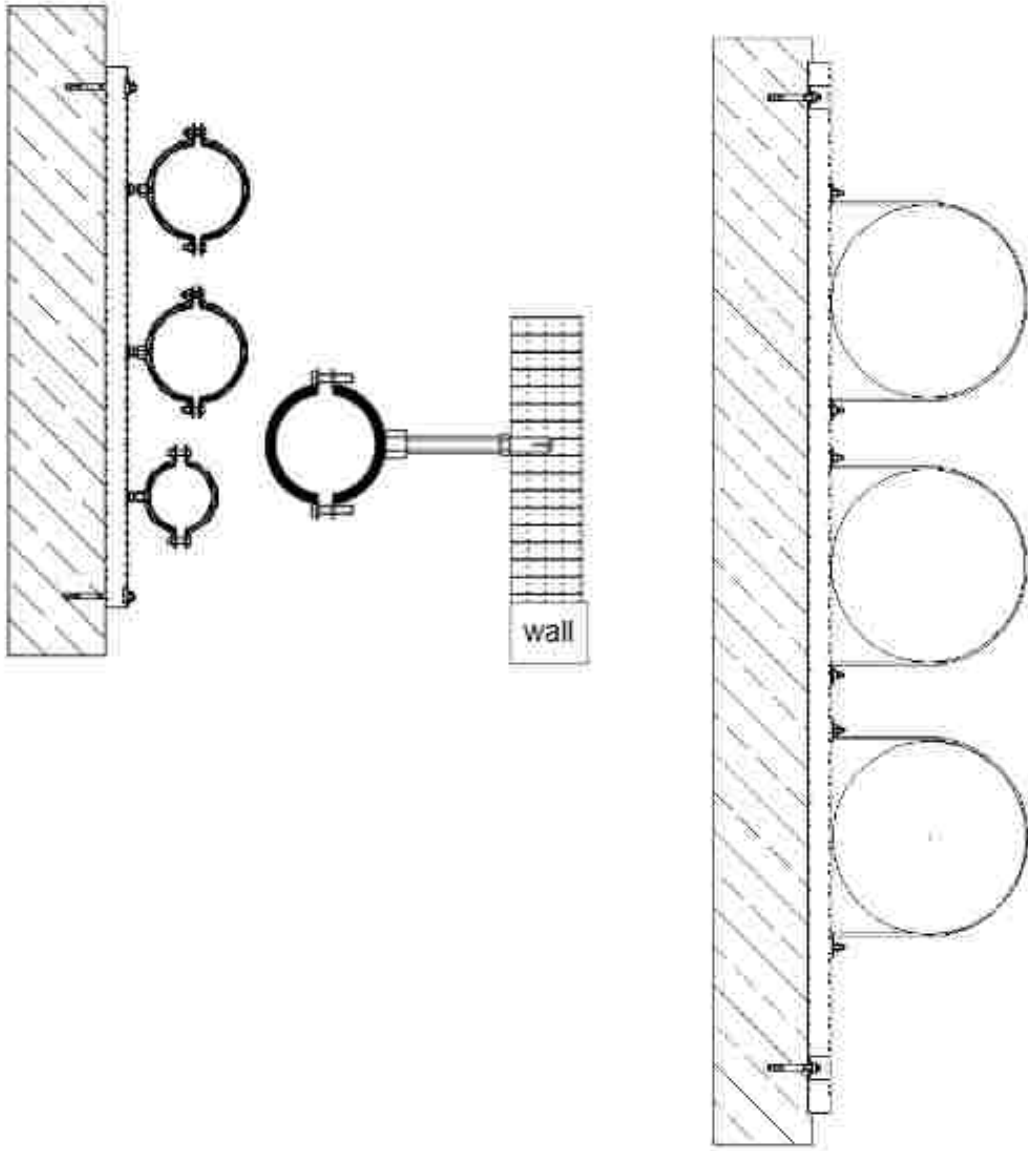

NAME OF WORK: CONSTRUCTION OF PUBLIC PLAZA AND UNDERGROUND PARKING FACILITY AT SANSKAR KENDRA - TAGORE HALL CAMPUS CONNECTING RIVERFRONT FOR SRFDCL

PLUMBING LIST OF APPROVED MAKES

Sr. No.	ITEM	APPROVED MAKE
01	CP Grating (P Trap)	Chilly/Futura/Jayna/Hightech/Kich/ Tece/ Viking/ Euronics
02	Ball Valve	Sant/Zoloto/Leader/Honeywell/Normax
03	Gun Metal Wheel Valve	Sant/Zoloto/Leader/Honeywell
04	Pressure Reducing Valve	Sant/Zoloto/Leader/Honeywell
05	Butterfly Valve	Sant/ Zoloto/ Leader/ Audco / Kitz / L&T / Kirloskar / Intervolve / Honeywell
06	Non-Return Valve	Sant/Zoloto/Leader/ Kirloskar /Normax /Honeywell
07	Cast Iron Manhole Cover	Kapilansh/Neco/Kejriwal
08	Cast Iron Grating	Kapilansh/Neco/Kejriwal
09	Upvc Pipes/Fittings	Astral / Supreme / Prince / Ashirvad
10	Cpvc Pipes/Fittings	Astral / Supreme / Prince / Ashirvad
11	Pvc Pipes/Fittings	Astral / Supreme / Finolex / Prince/ Ashirvad/ Dutron
12	Ductile Iron/Cast Iron Pipes/Fittings	Jindal / Tata / Reliance / Saint Gobain / Kejriwal / Electrosteel / Kejriwal
13	Minerally Reinforced Polypropylene High Density Low Noise Pipe	Huliot/Geberit/ Wavin/ Astral
14	Water Meter	Elster / Itron (Actris) / Zener / Sapple Sant / Kranti / Capstan / Honeywell / Adm
15	Water Level Indicator	Sant / Sigma / Gelco / Honeywell / Abb / E+H / Krohne / Seimens / Vega / Emerson
16	Hydro Pneumatic System	Franklin/Grundfos/Xylem/Ksb/Kirlosker/Wilo/Lubi
17	Water Softener System	Pentair/Ion Exchange/ Powerh2o/Gopani/Cleantech/
18	Submersible Pumps	Grundfos/Xylem/Ksb/Kirlosker/Wilo/Lubi/ CG / Jyoti
19	Non Clog Submersible De Watering Pump	Grundfos/Xylem/Ksb/Kirlosker/Wilo/Lubi/ CG / Jyoti
20	Mud Pump For Drainage	Grundfos/Xylem/Ksb/Kirlosker/Wilo/Lubi/ CG / Jyoti
21	Domestic Ro System	Pentair/Ion Exchange/Powerh2o/ Gopani/Cleantech
22	Water Cooler	Blue Star/Voltas/Usha/ Eureka Forbes
23	Electric Geyser	Jaquar/Ao Smith/Venus/Bajaj / Havells
24	Ball Float Valve	Prayag / Zoloto
25	Sewage Treatment Plant	Shubham India/JP Projets /Ion Excahnge/Aakar Engineers/

Sr. No.	ITEM	APPROVED MAKE
26	Domestic/ Rain Water Treatment Plant	Shubham India/Thermax/Ion Exchange/Aakar Engineers/Ene Fluidtek Pvt Ltd
27	Dwc Pipe	Astral/ Gemini/ Supreme / Noble/ Prince
28	Motor	Abb/Bbl/Bhel/Cgl / Siemens / Kec / /Havells
29	Hdpe Pipe	Ril / Sanghir / Dutron / Supreme / Reliance
30	Rcc Hume Pipes External Main Under Ground Pipe	Indian Hume Pipe/Pranali/Alcock
31	C.I. Pipe & Fittings	Neco/Bengal Iron /Electrosteel/Kejriwal/ Kapilansh /
32	Frp Manhole Cover	Everalst/Themodrain/Hp International/Sintex
33	Ms/G.I. Pipes	Tata / Jindal / Asian
34	G.I. Pipes Fittings Water Supply	Zoloto / Ambika / Tata / Surya / Jindal / Asian
35	Gi To Gi Joints	Champion/Crown/Diamond / Ambika / Tata / Surya / Jindal / Asian
36	Tar	Shalbond/Tikibond-Bs/Swastik
37	External Hot Water Pipe Insulation Component: EPDM	ALPAeroflex/ Armaflex/ Aerocell
38	Solvent Cement	Supreme/Finolex/Astral / Prince
39	Starter	Siemens / L&T / Abb / Ab / Schneider / Denfoss / Hitachi / Keb
40	Pressure Gauge	Bells/H Guru/Denfoss / Baumer / H.Guru / Bells / Manometer / Gic
41	Water Transfer Pump	Grundfoss / Xylem / Kirloskar/ Ksb /Wilo Mather And Platt
42	Metallic Expansion Bellows	Bellow.Flex/Precision/Dhruv/B.D. Engr.
43	Cables	Finolex / Havells / Rr Kabel / Polycab
44	UV	Bio Uv / Atg Uv / Trojan Uv / Ultraaqua / Xylem / Alpha / Eureka Forbes / Sukrut
45	Rainy Filter	Neerain/Rainy/Approved Equivalent As Approved By Eic
46	Sluice Gate	Jash / Ivc / Bic / Yashwant
47	Air Release Valve	Kirloskar / Ivc / Intervalve / Audco / Zoloto/R.B.
48	Gully Trap	Perfect/Rk/Anand
49	Slot Drain	Fuji/Aco/Approved Equivalent As Approved By Eic
50	Air Vent Valve	Avk / Kirloskar / Jainsons Industries (Jsi) / Sant / Zoloto
51	Pipe Support, Hangers	Intello Tech/Camry/Hilti/Fischer
52	Ss Pipe	Tata / Jindal / Reliance / Remi / Ratnamani
53	Strainer	Ksb / Kitz / Emerald / Amiad / Gopani / Ansys / Hy-Precision / 3m Cuno
54	Electromagnetic Flow Meter	Honeywell / E&H / Abb / Khrono Marshall / Seimens
55	Heat Pump (Air To Water)	Solahart/Ao Smith/Benchmark/Suntech.
56	Percolation Well	*Furaat/Vardhman/Space Element.

Sr. No.	ITEM	APPROVED MAKE
57	Loft Tank (Hdpe)	Sintex/Supreme/National
58	Solid Waste Composter	Dcs Techno/Smart Enviro/Envicare/Greenera Engineering
59	Bins & Container	Sintex/Nilkamal/Supreme
60	Membrane	Ge / Torray / Dow / Hydranitic / Dupont
61	Hot Water Recirculation Pump	Franklin / Grundfos / Xylem / Kbl / Ksb/Wilo
62	Sanitary Fixtures and Fittings	Astral/ Jaquar/Euronics / Cera
63	Grease Interceptor	ACO, Wade, Ashirvad, Supreme