

SABARMATI RIVERFRONT DEVELOPMENT



**Sabarmati River Front Development
Corporation Limited**

**2nd Floor, Riverfront House,
B/h H.K Arts College,
Between Gandhi Bridge and Nehru Bridge,
Pujya Pramukh swami Marg
(River Front Road-West)
Ahmedabad-380009**

BID DOCUMENT

**CONSTRUCTION OF RIVERSIDE
SAVORIES I.E. BUILDING WITH
UNDERGROUND ROAD BETWEEN
NEHRU BRIDGE AND ELLISBRIDGE
AND CONSTRUCTION OF PUBLIC
PLAZA AND UNDERGROUND
PARKING FACILITY AT SANSKAR
KENDRA - TAGORE HALL CAMPUS
CONNECTING RIVERFRONT ON
WESTBANK FOR SRFDCL.**

Contract Package : SRFDCL

VOLUME-02

IV) Technical Specification-FFTG



SECTION IV
TECHNICAL SPECIFICATIONS
Part A: - Riverside Savories



TECHNICAL SPECIFICATION FOR FIRE FIGHTING SYSTEM WORK	3
1.1 Scope of Work:	3
1.2 Fire Extinguisher:.....	3
1.3 Pipe Work:	4
1.4 Valves.....	6
1.5 Internal Hydrant:	11
1.6 Hoses	11
1.7 Hose Cabinets (Hose Box).....	11
1.8 Hose Reel.....	11
1.9 Branch Pipes	12
1.10 Yard / External Hydrant.....	12
1.11 Valve Chambers.....	12
1.12 Fire Brigade Inlet Connection	12
1.13 System Drainage.....	12
1.14 Hydrant System	13
1.15 Pumps and ancillary equipment.....	13
1.16 R.C.C. PIPES	16
1.17 Pressure Gauge	24
1.18 Pressure Switches	24
1.19 Sprinkler Heads	25
1.20 Sprinkler System	25
1.21 Testing of the hydrant system:	26
1.22 Start-Up/System Testing.....	27
1.23 Technical Data Sheet.....	28
1.24 Installation of Engineered Support System.....	29
1.25 Fire Bucket:.....	38
1.26 Gunmetal orifice plates:.....	39
1.27 Air release valve:	39
1.28 Reflux Valve (Non-Return Valve).....	39
1.29 Air vessel:	42
1.30 Strainer:.....	43
1.31 Expansion Bellow:	43
1.32 Ball Valves:.....	44
1.33 MCC For Fire Pumps:	44
1.34 Cable Gland, Lugs, XLPE Armoured Cable:	45
1.35 Rigid PVC Pipes:	53



TECHNICAL SPECIFICATION FOR FIRE FIGHTING SYSTEM WORK

1.1 Scope of Work:

The scope includes fire protection system only; the detection is covered under separate tender

- a. Fire Hydrant system.
- b. Fire Sprinkler System.
- c. Fire Extinguishers.

The detailed scope is described in the chapter "Extent of Work."

1.2 Fire Extinguisher:

General:

The scope of work under this part of the specification covers supply and installation of internal appliances as per requirements specified in schedule & marked on drawings and instructions of engineer-in-charge.

Makes of all the appliances supplied and installed shall be as per the 'List of Approved Make' or as approved by LFA and shall be of identical design for the entire premises.

Mounting accessories, indicator boards etc are part of the scope of supply of internal appliances.

Specifications:

Internal appliances with various fire extinguishing medium shall conform to the following specifications and shall be installed and maintained as per IS: 2190 / NFPA 10

- | | |
|-----------|---|
| IS: 2878 | Fire extinguisher, portable CO ₂ |
| IS: 2171 | Fire extinguisher, portable, dry powder type. |
| IS: 13849 | Fire extinguishers, ABC stored pressure type |

Portable Extinguishers of the following types shall be installed. Extinguisher to be mounted on wall.

1. ABC (Powder Type)
2. Co₂ type
3. CLEAN AGENT Automatic Modular (Self Activated)

ABC (Powder Type)

6 Kg ABC (Powder Type-MAP 90%) Fire Extinguisher. In HP Mild Steel Cylinders ISI marked fitted with pressure indicating gauge, internal tube, squeeze lever type valve fully charged with ABC powder (Mono Ammonium Phosphate) pressured by Nitrogen complete in all respects including wall suspension bracket and conforming to IS:15683.



CO2 TYPE:

The Co2 Extinguisher shall be ISI mark, with initial charge with high pressure cylinder, complete with wheel type valve, internal discharge tube, with high pressure discharge hose with horn and suspension brackets. The extinguisher shall have ISI mark of 2878 and capacity shall be 4.5 Kgs.

The Co2 Extinguisher of 22.5 kg. Capacity shall have ISI mark 2878 and necessary wheel valve, discharge hose and shall be mounted on light weight rubber tyre wheels.

CLEAN AGENT Automatic Modular (Self Activated):

Supplying, installation testing and commissioning of CLEAN AGENT Automatic Modular (Self Activated) fire extinguisher Automatic type. 5 kg Fire Extinguishers, Applicable fire classes A, B & C, UGTS Pressure Gauge. Empty Weight 2.64 kg, Full weight 7.64 kg, Can Height 370mm, Diameter 230 ± 10mm, made up from 2 mm thick sheet, Body Construction Deep Drawn with MIG Welding technology, Brass forged sprinkler valves with Nozzle is specially designed to give more than 95% discharge. Together with orifice characteristic to cover adequately fire risks with scattering cone of 40 to 45° Angle. Internal & External Pure polyester (UV Resistant) powder coated, Heat Sensitive Glass bulb of 68 °C. including pressure indicating gauge, ceiling mounted bracket.

Supplying, installation testing and commissioning of CLEAN AGENT Automatic Modular (Self Activated) fire extinguisher Automatic type 15 kg Fire Extinguishers Applicable fire classes A, B & C, UGTS Pressure Gauge, Empty Weight 6.40 kg, Full weight 21.40 kg. Can Height 425mm. Diameter 400 ± 10mm, made up from 2 mm thick sheet, Body Construction Deep Drawn with MIG Welding technology, Brass forged sprinkler valves with Nozzle is specially designed to give more than 99% discharge. Together with orifice characteristic to cover adequately fire risks with scattering cone of 40 to 45° Angle. Internal & External Pure polyester (UV Resistant) powder coated, Heat Sensitive Glass bulb of 68 °C. including pressure indicating gauge, ceiling mounted bracket.

Signages:

Providing & Fixing AUTOGLOW Signages in Block / Small Letters of Specified Sizes in BOQ. Signages shall be as per IS 12349-1988. The colour red, green and yellow, shall conform to Shade No. 536, 221 and 309 of IS: 5-1978. Colours for ready mixed paints and enamels (third revision) respectively. The paint shall conform to IS: 2932-1974 'Specification for enamel, synthetic, exterior (a) undercoating, (b) finishing (first revision).

1.3 Pipe Work:

General requirements:

- A All the materials shall be of ISO/LFA approved, best quality conforming to the specifications and subject to the approval of the Client or his representative. If so directed, materials shall be tested in an approved testing laboratory & the contractor shall produce the test certificate in original to the Engineer-in-charge & the entire charges for original as well as repeated tests shall be borne by the Contractor.



- B Before welding, the pipe faces shall be cleared & then shall be welded conforming to IS: 9595 – 1996. The electrodes used for welding shall comply with IS: 814. The laying of welded pipe shall also comply to IS 5822 – 2004. The welding joints shall be tested in accordance to IS: 3600, Part 1973.
- C Pipes and fittings shall be fixed truly vertical, horizontal or in slopes as required in a neat workman like manner.
- D Pipes shall be fixed in a manner as to provide easy accessibility for repair and maintenance and shall not cause obstruction in shafts, passages etc.
- E Pipes shall be securely fixed to walls and ceilings by suitable clamps or supported at every 3 mtr. & at change of direction as required. Only approved type of anchor fasteners shall be used for RCC ceiling and walls.
- F Valve and other appurtenances shall be so located that they are easily accessible for operations, repairs and maintenance.

1. PIPING

Pipes of the following types are to be used:

- A. MS/ G.I. pipes as per IS: 1239, heavy duty (for pipes of sizes 150 mm N.B. and below) suitably lagged on the outside to prevent soil corrosion. M.S. pipes buried below ground shall be lagged as per IS: 10211.
- B. MS/GI pipe lines upto 150 mm dia. shall have all fittings as per IS: 1239, Part-II (heavy grade) while pipelines above 150 mm dia shall be fabricated from IS: 3589 Gr.320 pipes as applicable or from steel plates.
- C. For MS/GI pipelines upto 50 mm dia screwed jointing shall be adopted, while for pipelines above 50 mm dia welded or flanged construction is to be carried out or as specified in Schedule of quantities.
- D. Hangers and supports shall be capable of carrying the sum of all concurrently acting loads. They shall be designed to provide the required supporting effects and allow pipeline movements as necessary. All guides, anchor, braces, dampener, expansion joint and structural steel to be attached to the building structure trenches etc. shall be provided. Hangers and components for all piping shall be approved by the Consultant / Client / Architect.
- E. The piping system shall be capable of withstanding 150% of the working pressure including water hammer effects.
- F. Flanged joints shall be used for connections to vessels, equipment, flanged valves and also on suitable straight lengths of pipeline of strategic points (@ at every 15-20 mtr.) to facilitate erection and subsequent maintenance work.
- G. Excavation for pipe line shall be in open trenches. Pipes shall be buried at least one meter below ground level and shall have 230 mm x 230 mm masonry supports at least 300mm high at 3m intervals. Masonry work to have plain cement concrete foundation (1 cement: 4 coarse sand: 8 stone aggregate) of size 380 x 380 x 75 thick resting on firm soil.



- H. Wherever required Contractor shall support all trenches or adjoining structures with adequate supports to prevent landslides.
- I. On completion of testing and painting trenches shall be refilled with excavated earth in 15 cm layers and compacted.
- J. Contractor shall dispose off all surplus earth within the site.
- K. Contractor shall provide suitable cement concrete anchor blocks for overcoming pressure thrusts in underground / external pipes. Anchor blocks shall be of cement concrete 1:2:4 mix.

1.4 Butterfly Valves

Butterfly valves as per IS - 13095/ 1991

- SCOPE - Fabricated valve will not be considered.
- This standard cover is double flanged and wafer type of metal seated, resilient seated cast iron, ductile iron, and carbon steel and lined butterfly valves for general purpose. Valves covered under this standard are manually, pneumatically, hydraulically or electrically operated.
- It covers valves of nominal pressure designations up to and including 4 MPa, and class 300 with ends flanged in accordance with appropriate table of IS 6418: 1971 'Cast iron and malleable cast iron flanges for general engineering purpose' or wafer type valves with bodies designed to be accommodate between pipe work flanges in accordance with appropriate table of IS 6418: 1971 or IS 6392: 1971 'steel pipe flanges' in nominal size DN 40 to DN 2000. It also covers valves up to class 300 and flanges as per the pressure/temperature ratings given in IS 13159 (Part 1): 1991 'steel pipe flanges and flanged fittings: part 1 dimensions and IS 6418: 1971 'cast iron and malleable cast iron flanges for general engineering purposes.
- REFERENCE
 - The applicable Indian standards are necessary adjuncts to this standard.
- TERMINOLOGY AND DEFINITIONS
 - Terminology and definition covered in IS 4854 (Part3) : 1974 are generally applicable.
- VALVE END CONNECTIONS
 - Double flanged valves
 - A valve having flanged ends for connection to pipe flanges by individual bolting.
 - Water valve
 - A valve for clamping between two pipe flanges using through bolting this may be single flange, lug type, U- section or flangeless type.
- SERVICE APPLICATIONS
 - Valves shall be suitable for one or more of the following applications.
 - Tight shut off - A valve having no visible leakage past the disc in closed position under test conditions.
 - Regulating - A valve intended for regulating purpose and which may have a clearance between the disc and the body in close position.
 - Low leakage - A valve which has specified maximum leakage rate past the disc in the closed position.



- **VACUUM CONDITION**
 - Where valve are to be used under vacuum conditions, purchaser shall mention specifically, and the detailed design provision shall be mutually agreed between the purchaser and the manufacturer.

- **NOMINAL SIZES**
 - The range of nominal valve size (DN) in mm shall be as follows:

 - 40,50,65,80,100,150,200,250,300,350,400,450,500,600,700,800,900,1000,1200,1400,1600,1800 and 2000

- **NOMINAL PRESSURES**
 - Valve shall be designated by nominal pressure (PN) defined as the maximum permissible working pressure (Mpa) at 20 0 C temperatures as follows:

 - PN 0.25, PN0.6, PN1.0, PN 1.25, PN 1.6, PN 2.0, PN 2.5 and PN 4.0.

 - The class designation for valves specified by nominal pipe size shall be class 125, class 150 and class 300.

- **PRESSURE/TEMPERATURE RATINGS**
 - Maximum permissible gauge working pressure and operating temperatures shall be in accordance with IS 6418 : 1971 and IS 13159 (Part I) : 1991 except that restriction on temperature may be placed by the manufacturer on valves in accordance with this standard by reason of valve type, trim materials or other factors. However, all valves shall be suitable for continuous use at their PN designation within the temperature range of -10⁰ c to 65⁰ c.

- **BODY ENDS**
 - Double Flanged Body Ends

 - The dimensions of flanged body ends and drillings shall be in accordance with the requirement given in Annex B. Flanges as per any other specific requirements of the purchaser may also be given as agreed to between the manufacturer and the purchaser or as per I.S. 13159 (part I) : 1991,

 - Flanges shall be at right angles to the axis of the bore and concentric with the bore.
 - Flanges shall be drilled unless otherwise specified and bolt holes shall be off centers. Tapped by the design of the valve.
 - Wafer Body Ends

 - Body ends shall be capable of being fitted between the pipe flanges complying with the requirements of annex B flange drilling.

 - The joint faces shall be at right angles to the axis of the bore and concentric with the bore.
 - Holes may be provided, where required by the design, for the passage of the bolts securing the flanges and the valve. Where through bolting is not practicable due to the presence of valve shaft, bearing housing, tapped holes may be provided for individual bolting of each flange.

- **FACE TO FACE DIMENSIONS**
 - Face to face dimensions of double flanged and wafer types of valve shall be as per Table 1.

 - Face to face dimensions given in Table 1 are exclusive of the sealing gaskets at both ends.

 - The manufacturer shall ensure that adequate space will be available between valve flanges for bolting when flanged valve with short body face to face or wafer long face to face are manufactured.



- Tolerance on face to face dimensions in Table 1 shall be as follow.

Face to face dimension of Unlined valve MM		Tolerance MM
Over	Up to and including	
0	250	+2
250	500	+3
500	800	+4
800	1000	+5
1000	2400	+6

- BODIES

- Bodies end ports shall be circular and the numerical values of the diameter shall be as close as possible to the valve of DN.

- DISC AND SHAFT

- The disc and shaft shall be designed to withstand the maximum pressure differential across the valve in either direction of flow. The shaft may be of one piece design or in two pieces separately attached to the disc. Any means of attachment between the shaft and the disc shall be such as to preclude components becoming loose in service.

- SEATING AND LININGS

- Non-integral seating, and lining where used, and their means of attachment shall be such as to preclude their becoming loose in service.

- BEARINGS

- The bearings shall be suitable for the maximum loads imposed by the shaft during testing and in service.
- For valves DN 350 and above, a bearing shall be provided to take the axial thrust, spring retaining clips (cir clips) shall not be used as thrust bearing.
- Suitable sealing shall be provided for the shaft where it passes outside the pressure containing enclosure.

- MATERIALS

- This standard is based on materials specified in Table 2. Unless otherwise agreed, the materials shall be of a grade equivalent to those given in Table 2 or superior. Other material may be used as per agreement between the manufacturer and the purchaser.

- OPERATION

- Manually Operated
- All valves shall be capable of operated at a differential pressure across the disc as marked on the valve. Lever, worm gear/traveling nut type or any other suitable type of operator can be used.
 - Direction
 - Unless otherwise, specified manually operated valves shall be closed by turning hand wheel or lever in a clockwise direction when facing the hand wheel or lever. The design of lever when fitted shall be such that the lever may only be assembled to the valve so that it is parallel to the direction of flow when the valve is open.
- All gear traveling nut operators shall be provided with suitable stops to prevent movement of the shaft beyond the limit corresponding to the fully closed position of the disc.
- All gear traveling nut operators shall be packed with grease for life time operation. Gear/traveling nut operators shall be totally enclosed and weather proof for general application. For special applications such as marine, submerged service etc. The purchaser may specify special enclosure.



- All gear/traveling nut operators shall be self locking type. All lever operated valve shall be capable of being locked at least three intermediate position.
- The operating hand-wheels shall be marked 'CLOSE' or 'SHUT' to indicate the direction of closer.
- The operator shall be provided with arrangement to indicate the disc position.
- TESTING
 - All valves shall hydrostatically tested by the manufacturer before dispatch. The pressure shall be obtained without any significant hydraulic shock. Testing shall be carried on before application of paint or other similar treatment unless otherwise agreed between the purchaser and the manufacturer. There shall be no air entrapped within the part of the valves subjected to test pressure.
- PERFORMANCE TESTING
 - Each valve shall be shop operated from fully closed to fully open position and reverse, under no pressure and no flow condition to demonstrate that the complete assembly is workable.
- BODY TEST
 - Completely assembled valve shall be tested as follows:
 - 'The body ends shall be blanked so that the valve is subjected to the full pressure in all directions include by the test pressure wafer valves may be tested in any suitable manner agreed between the purchaser and the manufacturer. The valve disc shall be in slightly open position and pressure equivalent to 1.5 times the maximum permissible working pressure shall be applied with water. The duration of this test shall be as in Table 3.'
- SEAT TEST
 - The seating surface of the valve shall be cleaned unless a surface treatment forms an integral part of the design or the use of a temporary surface treatment has been agreed between the manufacturer and the purchaser to avoid the possibility of damage under the condition of the test.

TABLE-3

NOMINAL DIA MM	MINIMUM TEST DURATION IN MINUTES	
	BODY TEST	SEAT TEST WHEN APPLICABLE
Up to and including 50	0.25	0.25
65 to 150	1.0	1.0
200 to 300	2.0	2.0
350 to 1000	5.0	2.0
1200 to 2000	5.0	3.0

- Each valve shall be shop tested for leaks in close position. The test shall be conducted with the body flanges in a horizontal position. Pressure shall be applied to the upstream end of the valve, the downstream being open to atmosphere. The duration of test shall be as per Table 3. There shall be no indication of leakage past the valve disc during test and valves shall be drop tight. Seat test shall be carried out in both the direction of valve if agreed between the manufacturer and the purchaser. The seat pressure applied on upstream side shall be equivalent to 1.1 times the maximum permissible working pressure at 20^o c and shall be applied with water.
- For regulating type valves seat test shall not be applicable.



- **DISC STRENGTH TEST**
 - The test shall be conducted with the body flanges in horizontal position. The test pressure shall be 1.5 times the maximum permissible pressure at 20 0 C With disc in closed position, hydro test pressure shall be applied to the lower face of the disc for duration as per table-3. There shall be no damage to the valve disc nor shall any part of valve or disc be permanently deformed by the test. The purpose of this test is to provide evidence of the adequacy and structural integrity of disc and body. Any leakage past the seat shall not be the criteria for rejection of the valve (Sampling test sample as per IS 2500). For regulating type valves, disc strength shall not be applicable.
 - Maximum permissible leakage shall be as per table 4.

- **TEST CERTIFICATES**
 - When specified by the purchaser, the manufacturer shall issue at test certificate conforming that the valves have been tested in accordance with this standard and stating the actual pressures and medium used in the test.

TABLE 4	
VALVE TYPE	LEAKAGE RATE
Tight shut-off	No visible leakage for duration of test
Low leakage	0.1 mm ² /s X DN (sec 5)
Regulating	Not specified. Outside the scope of this standard.

- **INSPECTION**
 - If inspection is required, this shall be stated in the enquiry/order. The purchaser or his authorized representative shall have access to the manufacturer's works at all reasonable times to inspect assembled valve to his order.
- **WITNESSING OF TESTS**
 - When the purchaser desires to witness the tests, this shall be specifically agreed in advance.
- **MARKING**
 - Marking shall be cast integral on the body or on a plate securely attached to the body. The markings shall be in accordance with I.S. 9866: 1981.
- **PREPARTION FOR DESPATCH**
 - Valve shall be complete in all respect when shipped. Each valve shall be drained, cleaned, prepared and suitable protected with 2 coats of red oxide on un machined surfaces and rust preventive coats on machined and flanged surfaces for dispatch in such a way as to minimize the possibility of damage and deterioration during transit and storage. Painting other than specified on the finished valve shall be as per the agreement between the manufacturer and the purchaser.
 - Disc shall be unseated when dispatched, but care shall be taken to ensure that there is no risk of damage to the disc.
 - When specified, the body ends shall be suitably sealed to exclude foreign matter during transit and storage.
 - Components shipped unattached shall be adequately protected and identified to permit correct field assembly.



1.5 Internal Hydrant:

Internal hydrant shall be provided at each landing or at suitable location consisting of single / twin headed gunmetal landing valve as indicated in BOQ with 63 mm dia oblique female instantaneous pattern with caps & chains. Outlet and 80 mm inlet (IS: 5290-1993) with separate shut off valve. Landing valves shall be 63 mm dia, oblique female instantaneous pattern with caps and chains. Landing valves shall be of gunmetal and fitted with instantaneous coupling conforming to IS: 901. The valve body, stop valve, checks valve, nut, instantaneous female outlet and blank cap shall be of leaded-tin bronze conforming to Grade-II of IS: 318-1962. The valve spindle shall be of brass rod conforming IS: 320 - 1962. The hand wheel shall be mild steel or cast-iron washers gaskets shall be of rubber conforming to IS:638 - 1965 or leather conforming to IS:581; 1969. The coupling shall be fitted with an internal plug secured by chain landing valves shall be installed on hydrant riser at a height of 1.0 to 1.2 meter from the floor level.

Each internal hydrant shall be provided with two nos. 63 mm. Diameter 15 mtr. Long hose pipe with gunmetal male and female instantaneous type coupling, machined wound with G.I. wire hose of IS 636 type A and couplings to IS:903 with IS certification, gunmetal branch pipe with nozzle conforming to IS:903.

1.6 Hoses

Hoses pipes shall be of fabric reinforced rubber lines as per IS:636 Type II or canvas hose as per IS:4927, with nominal size of 63 mm and lengths of 15 meter or 7.5 meter, as per quantities specified for in schedule or bill of quantity.

All hose pipes shall carry ISI marking on the body of the hose.

The hose shall have instantaneous spring lock-type coupling on ends. The instantaneous coupling shall be as per IS: 901. It shall be fixed to each other by copper rivets and galvanized M.S. wires and leather bands. All coupling shall be interchangeable with each other and shall bear ISI markings.

1.7 Hose Cabinets (Hose Box)

Each hydrant shall be housed in a Hose cabinet of suitable size. The hydrant cabinet shall hold double / single headed hydrant as specified, 2 hoses and one branch pipe as required. Internal hydrants shall normally fit the size of the niche made for it. The cabinet shall be of minimum 16 SWG M.S. sheet with center opening, double glass front doors (clear glass of 4mm thickness). The glass shall be firmly fixed by means of steel clips and screw with rubber beading. Hinges shall also be screwed and not welded. The corner members (frame) shall be of 25 x 25 x 3 mm thick angle. The hose box shall be firmly fixed to the wall/support by means of brackets and dash fasteners. The steel work shall have one coat of primer and two coats of red paint. The words "Yard Hydrant", "Hydrant" etc. should be painted in white or red on the glass in 75 mm high letters. The hose box shall be lockable for internal hydrant installation.

1.8 Hose Reel

The hose reel shall be directly tapped from the riser through a 25 / 32 mm dia pipe, the drum and the reel being firmly held against the wall by use of dash fasteners. The hose reel shall be swinging type (180degrees) and the entire drum, reel etc. shall be as per IS: 3876 and IS: 884. The rubber tubing shall be of best quality and the nozzle shall be shut off type.



1.9 Branch Pipes

Branch pipe shall be of either gun metal or aluminum and should conform to IS: 903. One end of the branch pipe will receive the coupling while the other end shall have a nozzle screwed to it. It shall bear ISI marking.

1.10 Yard / External Hydrant

Yard or External Hydrants shall be as per IS: 908 and the valve as per IS: 5290. The hydrant shall consist of stand post assembly and a masonry base 200 mm X 200 mm X 200 cm high and shall be made at the point where it comes out of the soil. The valve shall complete with hand wheel, quick coupling connection spring and blank cap. The hydrant shall be laid on 150 dia. or as mentioned in BOQ.

Yard or External hydrant shall have oblique female instantaneous pattern 63 mm diameter outlets with caps and chains. The hydrant shall be of gunmetal and flange inlet and single outlet conforming to IS: 5290, a duck foot bends and flanged riser of required height to bring the hydrant to level above ground. The valve body, stop valve, checks valve, nut, instantaneous female outlet and blank cap shall be of leaded-tin bronze conforming to Grade-II of IS: 318-1962. The valve spindle shall be of brass rod conforming IS: 320 - 1962. The hand wheel shall be mild steel or cast iron washers gaskets shall be of rubber conforming to IS:638 - 2003 or leather conforming to IS:581 : 1969.

Each external hydrant shall be provided with two nos. 63 mm. Diameter 15 mtr. Long hose pipe with gunmetal male and female instantaneous type coupling, machined wound with G.I. wire hose of IS 636 type A and couplings to IS:903 with IS certification, gunmetal branch pipe with 20 mm nozzle conforming to IS:903.

1.11 Valve Chambers

A valve chamber shall be brick masonry chamber in cement mortar 1:5 (1 cement: 5 coarse sand) on cement concrete foundation 150 mm thick foundation 1:5:10 mix (1 cement: 5 fine sand: 10 graded stone aggregate 40 mm nominal size), 15 mm thick cement plaster inside and outside finished with a floating coat of neat cement inside with cast iron surface box approved by fire brigade including excavation, back filling, complete. The wall shall be 230 mm thick with heavy duty ISI marked C.I. manhole covers.

1.12 Fire Brigade Inlet Connection

A fire brigade inlet connection with a non-return valve shall be provided to facilitate the fire brigade to pump water into the installation by the use of their own equipment. Four way or 150 mm dia connection to the system shall comprise of four instantaneous pattern 63 mm dia. male inlets shall be with caps and chains complete with 150 mm dia. sluice valves, non-return valve housed in a M.S. cabinet with glass fronted door. The cabinet shall be suitable for recess mounting.

Two way or 100 mm fire brigade inlet connection to the system shall comprise of two instantaneous pattern 63 mm dia. male inlets shall be with caps and chains complete with 100 mm dia sluice valve, non-return valve housed in a M.S. cabinet with glass fronted door. The cabinet shall be suitable for recess mounting.

1.13 System Drainage

The systems shall be provided with suitable drainage arrangements with G.I. /MS piping of 50 mm dia. complete with all accessories and provided with drain valve.



1.14 Hydrant System

The hydrant system shall comprise of AC motor driven pump sets. Diesel pump, Jockey pump etc. with all required accessories including valves, appurtenances, instrumentation and controls etc. complete in all respects. The system shall cover the entire area from independent pipe work from the fire water pump set. The hydrant work shall remain pressurized through the proposed Jockey pump taking care of any leakages in the system pipelines and valve glands. All pumps / motors / engines to be of makes approved by local Fire Authority.

The hydrant system shall be kept charged by pressurized water at approximately 7.5 Kg/cm² at all times. In the event of fire when any of the hydrant valves in the network is opened, the resultant fall in header pressure should enable starting the Electric Motor driven fire water pumping set through pressure switches automatically. One Diesel Engine / DG set driven pump shall be a stand-by pump serving hydrant system & sprinkler both. In case of failure of electricity or failure of Elec. Pump to start on demand, the stand-by DG set operated pump shall automatically take over. Apart from the automatic starting of the pump sets, provision shall be kept for manual starting also. However, shifting down of the pump sets shall be manual.

The hydrant system in the yard shall be furnished with external hydrants consisting of landing valves (positioned approx. one meter above ground level) fitted M.S. (Heavy) flanged single headed standpipes installed on underground hydrant headers distributed 45 M apart approximately or as marked on the plan.

The entire system including all pumps, motors, diesel pump set and panels shall be of approved make by ISO / Local Fire Authority.

1.15 Pumps and ancillary equipment

Scope of Work

- A. Work under this section shall consist of furnishing all labour, materials, equipment and appliances necessary and required to completely install electrically operated pumps for fire hydrant installations as required by the drawings and specified hereinafter or given in the schedule of quantities.
- B. Without restricting to generality of the foregoing the pumps and the ancillary equipment and shall include the following:
 - a. Electrically operated pumps with motors base plate and accessories.
 - b. Pump suction and delivery headers, valves, air vessel and connections.
 - c. Pressure gauges / pressure switch.
 - d. Only single point 3 phase supply will be made available to the Contractor. From there, all provision viz. Electrical switchboard, wiring, cabling, cable tray, control panel, earthing, etc. shall be made.

General Requirement

- a) Pumps shall be installed true to level on suitable concrete foundations. Base plate shall be firmly fixed by foundation bolts properly grouted in concrete foundations.



- b) Pumps and motors shall be truly aligned with suitable instruments.
- c) All pump connections shall be standard flanged type with appropriate number of bolts.
- d) Manufacturer instructions regarding installation connections and commissioning shall be followed with respect to all pumps, switchgear and accessories.

Fire and Jockey Pumps

- a) The main Fire hydrant & Sprinkler pumps shall be End Suction Back Pull Out / Split Casing type while Jockey pumps shall be of Centrifugal Mono block Pump type having following specifications.
- b) Shut off head should not exceed 140% of rated head. Pump shall not develop less than 65% of rated head at 150% of rated capacity

MATERIALS OF CONSTRUCTION

Part	Material
Casing	Cast Iron
Impeller	Bronze IS: 318, Gr. LTB 2
Casing Wearing	SS
Shaft	AISI – 410 / Stainless Steel
Shaft Sleeve	S.S. 316
Stuffing Box	Gland Packed

- c) Pumps shall be provided with pressure gauge with isolation cock on the delivery side.
- d) In case of motor driven pump the motor rating should be adequate to drive the motor rating should be adequate to drive the pump at 150% of rated discharge.
- e) The pump and its prime mover (Electric motor or Diesel Engine) shall comply with all the equipment of the Rules of the Traffic Advisory Committee.
- f) All pumps shall have positive suction & shall be provided with suction strainer of SS & CI bell mouth. In case of negative suction suitable priming arrangement shall be provided.
- g) In first phase only, all pumps shall be installed. Pump head shall be considering ultimate phase.

Jockey Pump

Starting and stopping of Jockey Pump set shall be automatic at predetermined levels through pressure switch. However, arrangements for manual start and stop of the pump shall also be made. Jockey Pump shall take care of small leakages in the piping system and pumps cushion tanks.

Electric Driven

Electrically driven pumps shall be provided with totally enclosed fan cooled, foot mounted, squirrel cage induction motors suitable for fire pumps with IP-55 enclosure.

The motors should be rated not to draw more than 4.5 times the starting current.



Motors shall be at least equivalent to the horse power required to drive the pump at 150% of its rates discharge.

The motors shall be wound for class-F insulation and windings shall be vacuum impregnated with heat and moisture resisting varnish, glass fiber insulated.

Diesel Engine

- a) Diesel engine shall have suitable no. of cylinders with individual heat assemblies. The engine shall be water cooled and shall include heat exchanger and connecting piping strainer, isolating pressure reducing valves, bye-pass line, exhaust pipe, silencer, day tank for fuel all interconnected piping etc., complete in all respects.
- b) Engine shall be direct injection type with low noise and exhaust omission levels,
- c) The speed of engine shall match the pump speed for direct drive.
- d) The engine shall be capable of being started without the use of the wicks, cartridge heater plugs or either at engine room temperature of 4°C and shall take full load within 15 seconds from the receipt of the signal to start.
- e) The engine shall effectively operate at 46°C ambient temperature at 150 meter above mean sea level.
- f) Engine shall be suitable for running on high speed diesel oil.
- g) The system shall be provided with a control panel with push button starting arrangement also wired to operate the engine on differential pressure gauge.
- h) The entire system shall be mounted on a common structural base plate with anti-vibration mounting, Dunlop make, and flexible connections on the suction and delivery piping.
- i) Contractor provide one fully mounted and supported Day Oil Tank fabricated form 6mm thick MS sheet electrically welded for 8 hours working load and having suitable capacity of oil. Provide level indicators – low level and full level in the Day Oil Tank on the control panel through float switches and a breather. Day Oil Tank shall also be provided with filling connection (Threaded) with cap, gauge glass indication and cocks, drain cock, inspection / cleaning cover with gasket and nuts / bolts. MS dyke to hold 150% of the Day Tank capacity to be built around the Day Tank.
- j) Contractor to provide one exhaust pipe with suitable muffler (residential type) to discharge the engine gasses to outside in open air as per site conditions (Contractor to check the site).
- k) Contractor to provide all accessories, fittings and fixtures necessary and required for a complete operating engine set. The exhaust pipe shall be taken outside the building with minimum number of bends (approx. length 30 Meters) and shall be duly heat insulated with 50mm thick glass wool covered with 24-gauge aluminum cladding.
- l) Contractor shall indicate special requirements, if any, for the ventilation of the Pump Room.
Noise & Vibration level of the pump driven by motor/engine shall be within the acceptable limits of ISO 2372, IS 11727.



BOOSTER PUMP:

A booster pump shall be provided at terrace to pressurize the wet riser system. The pump shall be centrifugal end suction / mono block type.

BASE PLATE

Pumps and motors shall be mounted on a common structural base plate and installed as per the manufacturer's instructions.

1.16 R.C.C. PIPES

SCOPE :

This specification covers the requirements for manufacture, supplying, lowering, laying, jointing, testing and commissioning of reinforced cement concrete (RCC) pipes used for the conveyance of sewage & storm water .

CODES & STANDARDS :

The manufacturing, testing, supplying, jointing and testing at work sites of RCC pipes shall comply with all currently applicable statutes, regulations, standards and codes. In particular, the following standards, unless otherwise specified herein, shall be referred.

MATERIALS

1. IS : 458 Specification for pre cast concrete pipes (with and without reinforcement)
2. IS : 3597 Method of tests for concrete pipes.
3. IS : 432 Specification for mild steel and medium (tensile steel bars and hand drawn steel) wires for concrete reinforcement.
4. IS : 5382 Specification for rubber sealing rings for gas mains, water mains & sewers
5. IS : 516 Method of test for strength of concrete.

CODE OF PRACTICE

IS : 456 Code of practice for plain and reinforced concrete

DESIGN

Design of RCC pipes including reinforcement details and the ends of pipes shall be in accordance with the relevant clauses of IS : 458.

GENERAL

The method of manufacture of RCC pipes (Class NP 3) shall be such that the form and the dimensions of the finished pipes are accurate within the limits specified in relevant clause of IS : 458. The surfaces and edges of the pipes shall be well defined and true, and their ends shall be square with the longitudinal axis. The ends of the pipes shall be further reinforced by an extra ring of reinforcement to avoid breakage during transportation.



The RCC pipes and rubber rings shall be systematically checked for any manufacturing defects by experienced supervisors so as to maintain a high standard of quality.

The engineer shall at all reasonable times have free access to the place where the pipes and collars/rubber rings are manufactured for the purpose of examining and testing the pipes and collars/rubber rings and of witnessing the test and manufacturing.

All tests specified either in this engineer's requirements or in the relevant Indian standards shall be performed by the supplier/contractor at his own cost and in presence of the engineer if he so desires. For this, sufficient notice before testing of the pipes and fittings shall be given to the engineer.

If the test is found unsatisfactory, the engineer may reject any or all pipes of that lot.

MATERIALS

1. CEMENT

sulfate resisting cement shall be used for the manufacture of RCC pipes and fittings and shall conform to IS 12330.

2. AGGREGATES

Aggregates used for the manufacture of RCC pipes shall conform to 3 of IS : 383. The maximum size of aggregate should not exceed one third the thickness of the pipe or 20mm, whichever is smaller for pipe size above 250 mm. For 80 to 250 mm size, the maximum size of the aggregate shall be 10 mm.

3. MIXING AND CURING WATER

Water shall be clean, colourless & free from objectionable quantities of organic matter, alkali, acid, salts, or other impurities that might reduce the strength, durability or other desirable qualities of concrete and mortar.

4. REINFORCEMENT

Reinforcement used for the manufacture of the reinforced concrete pipe shall conform to mild steel Grade 1 or medium tensile steel bars conforming to IS : 432 (part-1) or hard-drawn steel wire conforming to IS : 432 (part-2) or structural steel (standard quality) bars conforming to IS 2062. Reinforcement cages for pipes and collars shall be as per relevant requirement of IS : 458.

5. CONCRETE

Concrete used for the manufacture of RCC pipes shall conform to IS : 456. The minimum cement content and minimum compressive strength of concrete shall be as per relevant requirements of IS : 456. Compressive strength tests shall be conducted on 15 cm cubes in accordance with the relevant requirements of IS : 456 and IS : 516.

CURING

Pipes manufactured in compliance with IS : 456 shall be water cured in accordance with the relevant requirements of IS : 456.

DIMENSIONS & TOLERANCE

- a. The internal diameter, wall thickness and length of barrel, reinforcement (longitudinal and spiral), type of ends and minimum clear cover to reinforcement and strength test requirements shall be as per the relevant clauses / tables of IS : 458 for class NP3 RCC pipes.



- b. The tolerances regarding overall length, internal diameter of pipes or sockets and barrel wall thickness shall be as per relevant clause of IS : 458.

WORKMANSHIP & FINISH

- a. Pipes shall be straight and free from cracks except that craze cracks may be permitted. the ends of the pipes shall be square with their longitudinal axis.
- b. The outside and inside surfaces of the pipes shall be smooth, dense and hard, and shall not be coated with cement wash or other preparation unless otherwise agreed to between the engineer and the manufacturer or supplier
- c. The pipes shall be free from defects resulting from imperfect grading of the aggregate, mixing or moulding.
- d. The pipes shall be free from local dents or bulges greater than 3 mm in depth and extending over a length in any direction greater than twice the thickness of barrel.
- e. The deviation from straight in any pipe throughout its effective length, tested by means of rigid straight edge parallel to the longitudinal axis of the pipe shall not exceed, for all diameters 3 mm for every meter run.

TESTING

- a. All pipes for testing purposes shall be selected at random from the stock of the manufacturer and shall be such as would not otherwise be rejected under the criteria of tolerances as mentioned in IS : 458.
- b. During manufacture, compressive strength of concrete cubes shall be done as described in IS 516. For pressure pipes, splitting tensile strength tests of the concrete cylinders shall be carried out as described in IS 5816. The manufacturer shall supply, when required to do so by the engineer, the results of compressive tests of concrete cubes and split tensile tests of concrete cylinders made from the concrete used for the pipes. the manufacturer shall supply cylinders or cubes for test purposes required by the engineer and such cylinders or cubes shall withstand the tests prescribed as per IS : 458. Every pressure pipe shall be tested by the manufacturer for the hydrostatic test pressure, for non-pressure pipes, 2 percent of the pipes shall be tested for hydrostatic test pressure in accordance with IS 458.
- c. The specimen of pipes for the following tests shall be selected in accordance with relevant clause of IS : 458 and tests in accordance with the methods described in IS : 3597.

- **Hydrostatic Test**
- **Three-edge bearing Test**
- **Permeability Test**

SAMPLING & INSPECTION



In any consignment, all the pipes of same class and size and manufactured under similar conditions of production shall be grouped together to constitute a lot. the conformity of a lot to the requirements of this specification shall be ascertained on the basis of tests on pipes selected from it.

The number of pipes to be selected from the lot for testing shall be in accordance with table 22 of IS : 458.

Pipes shall be selected at random. In order to ensure randomness of selection, all the pipes in the lot may be arranged in a serial order and starting from any pipe, every pipe shall be selected till the requisite number is obtained and or procedures given in IS 4905 may be followed.

All pipes selected shall be inspected for dimensional requirements, finish and straightness. A pipe failing to satisfy one or more of these requirements shall be considered as defective.

The number of pipes to be tested for tests under clause 10.2 shall be in accordance with column 4 of table 22 of IS : 458. These pipes shall be selected from pipes that have satisfied the requirements of dimensions, finish and deviation from straight.

A lot shall be considered as conforming to the requirements of IS : 458 if the following conditions are satisfied.

The number of defective pipes (those not satisfying one or more of the requirements for dimensions, finish and deviation from straight shall not be more than the permissible number given in clause 8 & 9 of IS : 458.

All the pipes tested for various tests as per Clause shall satisfy corresponding requirements of the tests.

In case the number of pipes not satisfying requirements of any one or more tests, one or two further samples of the same size shall be selected and subjected to the test or tests in which the failure has occurred. All these pipes shall satisfy the corresponding requirements of the test. In the event they do not, the lot will be rejected.

MARKING

The following information shall be clearly marked on each pipe :

- a. Internal diameter of pipe
- b. Class of pipe
- c. Date of manufacture an
- d. Name of manufacturer or his registered trademark or both.

CARTING & HANDLING

Unless waived by the engineer, method statements shall be submitted by the contractor for the approval of the engineer before the handling, transportation and laying of any pipes commences. All pipes shall be handled and stored in compliance with the manufacturer's recommendations. Pipes and fittings /specials shall be transported from the factory to the central pipe store and unloaded there before being transported to site. At every point of loading or unloading, all pipes and fittings shall be lifted using approved lifting tackle. Unloading by rolling down any form of inclined ramp will not be permitted. Pliable straps or slings shall be used to lift pipes. Rope, wire rope, hooks or chains shall not be allowed to come into contact with any pipe surface. All pipes shall be thoroughly inspected on arrival on site and immediately prior to installation. Any damage to the pipes shall be notified to the engineer for a decision as to the acceptability of the pipes, with or without repairs or remedial work. The final judgement will be taken by the engineer based on his judgement of the suitability of the items for the purpose intended.



STORAGE

Each stack of pipes shall contain only pipes of same class and size, with consignment or batch number marked on it with particulars of suppliers wherever possible. storage shall be done on firm level and clean ground and wedges shall be provided at the bottom layer to keep the stack stable. the stack shall be in pyramid shape or the pipes laid lengthways and crosswise in alternate layers. the pyramid stack shall be made for smaller diameter pipes for conserving space in storing them. the height of the stock shall not exceed 1.5 m.

Rubber rings shall be stored in a clean, cool store away from windows, boiler, electrical equipment and petrol, oils or other chemicals.

PIPELINE CONSTRUCTION (GENERAL)

Pipes shall be laid and jointed in accordance with all relevant recommendations of the manufacturer. Any variations between the manufacturer's recommendations and this specification shall be highlighted in the contractor's method statements and a ruling will be given with the approval. All pipelaying shall be performed by experienced and competent pipelayers.

The line of the pipe shall be set out and agreed with the engineer well in advance of the excavation. Surface stripping, excavation, pipelaying, backfilling and reinstatement shall follow each other without undue delay or interval between these activities.

LAYING OF PIPES

In laying the pipes and fittings/ specials the center for each manhole / chamber or pipeline shall be marked by a peg. Contractor shall dig holes for and set up two posts (about 100 x 100 x 1800 mm) at each manhole / chamber or junction of pipelines at nearly equal distance from the peg and at sufficient distances there from to be well clear of all intended excavation, so arranged that a sight rail when fixed at a certain level against the post shall cross the center line of the manhole/chamber or pipe lines. the sight rail shall not in any case be more than 30 m apart, intermediate rails shall be put up if directed by engineer.

Boning staves of 75 mm x 50 mm size shall be prepared by contractor in various lengths, each length being of a certain whole number of meters and with a fixed tee head and fixed intermediate cross pieces, each about 300 mm long. The top-edge of the cross piece must be fixed below the top-edge of the tee-head at a distance equal to the outside diameter of the pipe or the thickness of the concrete bed to be laid as the case may be. the top of cross pieces shall indicate different levels such as excavation for pipe line, top of concrete bed, top of the pipe etc. as the case may be.

The sight rail of size 250 mm x 40 mm shall be screwed with the top edge resting against the level marks. The centre line of the pipe shall be marked on the rail and this mark shall denote also the meeting point of the centre lines of any converging pipes. a line drawn from the top edge of one rail to the top edge of the next rail shall be vertically parallel with the bed of the pipe, and the depth of the bed of pipe at any intermediate point may be determined by letting down the selected boning staff until the tee head comes in the line of sight from rail to rail.

The post and rails shall be perfectly square and planed smooth on all sides and edges. the rails shall be painted white on both sides, and the tee-heads and cross-piece of the boning staves shall be painted black.

For the pipes converging to a manhole/chamber at various levels, there shall be a rail fixed for every different level. when a rail comes within 0.60 m of the surface of the ground, a higher sight-rail shall be fixed for use with the rail over the next point. the posts and rails shall in no case be removed until



the trench is excavated, the pipes are laid and engineer gives permission to proceed with the backfilling.

LAYING OF PIPES & FITTINGS/SPECIALS

The joints and interiors of all pipes and fittings shall be carefully cleaned before installation. whenever pipelaying is interrupted for any reason, the open end of the pipeline shall be sealed with a suitable expanding stopper or a properly fitted temporary wooden stopper and exposed pipes shall be suitably protected from stones and other objects falling into the trench from above.

The permissible tolerance for pipelines in trenches shall be 6mm in level and 25mm in line between manholes. After the laying of a length of a pipeline but before testing the crown of the pipe shall be checked for level and alignment and any necessary adjustment made by unjointing and removing the pipes concerned, adjusting the bedding, relaying the pipes and rechecking for line and level.

For pipeline jointing systems incorporating flexible jointing rings, pipes shall be laid with the spigot end pointing in the direction of flow and with a gap between the end of the spigot and the base of the socket, or between spigots. rubber rings shall comply to IS : 5382.

JOINTING

Pipe section shall be joined utilising spigot and socket flexible joint with rubber ring, as per relevant IS after jointing, extraneous material, if any, shall be removed from the inside of the pipe and the newly made joints shall be thoroughly cured. the rubber sealing rings used for jointing, shall conform to IS : 5382.

The RCC pipe with the rubber ring accurately positioned on the spigot shall be pushed well home into the socket of the previously laid pipe by means of uniformly applied pressure with the aid of a jack or similar appliance. The RCC pipes shall be of spigot and socket type and rubber rings shall be used, and the manufacturer's instructions shall be deemed to form a part of these engineer's requirements. The rubber rings shall be lubricated before making the joint and the lubricant shall be soft soap water or an approved lubricant supplied by the manufacturer.

BEDDING

The type of bedding for the RCC pipes (granular, concrete cradle – PCC, RCC, concrete encasement, etc.).

GRANULAR BEDDING

1. Material used for bedding should be of granular material, free from sharp edges and sharp angles, well graded and durable under influence of ground water. The material selected shall consist of gravel (uncrushed or crushed), crushed rock or crushed concrete. uncrushed gravel is obtained from the natural disintegration of rock.
2. Well graded gravel of varying size from 5 mm to 14 mm shall be used. percentage distribution of each size for graded aggregate is mentioned in table 2.1 below.
3. Where pipes are laid with a granular bed or surround the appropriate bedding material shall, as soon as a section of trench has been trimmed to grade, be placed carefully over the full trench width without segregation. The material shall be spread and thoroughly compacted by approved mechanical means in successive uniform layers each not exceeding 150 mm compacted thickness to produce a uniform bed to the required gradient. where plate vibrators are used, there shall be a minimum of one pass for crushed stone and two passes for sands. hand tamping will only be permitted where insufficient space is available to allow the use of mechanical plant. the minimum thickness of compacted granular material shall be as follows:-



4. 150mm (minimum 100mm under sockets) for pipes not exceeding 300mm nominal diameter, except when trench is in rock.
5. 200mm (minimum 100mm under sockets) for pipes greater than 300mm nominal diameter, or all pipes when trench is in rock.
6. The pipes shall then be set evenly on the bed, great care being taken to ensure uniform support for the entire length of the pipe.
7. Pockets in the bedding shall be formed at each pipe joint to permit jointing to be carried out without the sleeve or socket of the pipe joint bearing on the bedding material and without bedding material entering the joint.
8. After the pipeline alignment and joints have been inspected and approved by the engineer, the water testing of the pipeline satisfactorily completed, and, where appropriate, the annular gap at each pipe joint sealed, each joint pocket shall be carefully filled with granular material and thoroughly compacted up to the same level as the top of the bedding. granular bedding material of the same type shall be placed on both sides of the pipeline in successive uniform layers not exceeding 150mm thick and compacted according to one of the methods given in table 2.2 as agreed with or directed by the engineer. care shall be taken to ensure that no cavities remain under the pipe, and that the pipes are not displaced by differential pressure from either side.
9. When placing and compacting surround material the contractor shall take care not to displace or damage the pipes. the tipping of surround material from ground levels directly onto the pipes shall not be permitted.
10. Unless otherwise detailed on the drawings, for pipes with a full granular surround the granular material shall extend up to a minimum height of 300mm over the crown of the pipes. for rigid pipes unless otherwise detailed, the granular material shall extend up to the springing level of the pipe. the surround shall be completed by the careful placing of selected excavated material in layers not exceeding 150mm thick, thoroughly compacted on both sides of the pipeline to a level at least 300mm above the crown of the pipes.
11. For pipelines of 600mm diameter or greater the bed should be prepared ahead for approximately two pipe lengths whilst two pipes are being laid and the previous two pipes are receiving side filling. for pipelines less than 600 mm diameter the lengths of each stage shall be agreed with the engineer.
12. If the contractor wishes to use any other method of laying pipes in granular bedding or surround he must submit his proposals in writing to and obtain the approval in writing from the engineer well in advance of the date when he wishes to perform the work.

CONCRETE BEDDING

Concrete shall be grade M 20 unless otherwise detailed on the drawings / BOQ.

The minimum thickness of concrete between the bottom of the pipe and the trench shall be 0.25 x nominal pipe diameter, subject to 150mm minimum, with a minimum 100mm beneath sockets.

The pipes shall be set to correct alignment as detailed below :-

The contractor may use rectangular concrete blocks (two per pipe) made of grade M15 concrete, cast at least 7 days before use, together with pairs of approved hardwood wedges of the same width as the blocks in order to align and support the pipe before concreting. the blocks and wedges shall be of sufficient size and suitably founded on the bottom of the trench to support the pipe adequately without



settlement or movement at any stage, the blocks and wedges should be placed near the end of each pipe length and should be left undisturbed during jointing of subsequent pipes and during construction, although the wedges should be removed during placing of the concrete.

Blocks may have thin tie wires cast in to assist in holding down the pipe when the concrete surround is being mechanically vibrated.

After approval of the joints and satisfactory testing of the pipeline a transverse flexible joint shall be formed by insertion of a template of compressible joint filler consisting of bitumen impregnated insulating board as per BS 1142 part 3 or other equally compressible material shaped exactly to the pipe and full extent of the concrete cradle or surround. unless otherwise specified, the thickness of this flexible joint shall be a minimum of 25mm.

For spigot and socket pipes, the flexible joint in the concrete shall be aligned with the face of the socket. For sleeve type and flexible mechanical joints, the flexible joint shall be aligned with one end of the sleeve or mechanical joint. In certain cases, a flexible joint may be required at both ends of the sleeve or mechanical joint. The concrete infill for flexible mechanical joints shall only be placed after the application of the specified protection materials to the joint. no steel reinforcement shall pass through the flexible joint.

Concrete for beddings, surrounds and joint infills shall be placed carefully and uniformly, suitable measures being adopted to ensure that the pipeline is not displaced by differential side pressure or by flotation. Concrete shall be properly compacted with particular care being taken to ensure that no cavities are left underneath the pipe.

The concrete shall provide a minimum cover to the pipe of 150mm for surrounds.

Concrete beds to pipes of all diameters and surrounds to pipes of one meter diameter or less shall be poured in a single operation. concrete surrounds to pipes over one meter diameter shall normally be poured in two lifts, with a horizontal joint not more than 100mm below the crown of the pipe. concrete shall be prevented from entering pipe joints.

Formwork shall be used for all vertical faces. Side forms should not normally be required, if trench widths specified are such that the concrete bedding / surround will extend the full width of the trench.

All formwork used for forming the concrete bedding shall be removed, unless the written approval of the engineer is given to leave it in place for safety or similar reasons. Where side forms have been required, backfilling shall be proper to fill the voids left on removal of the formwork.

The bedding and surround shall be completed by the careful placing of selected excavated material in layers not exceeding 150mm thick, thoroughly compacted by hand on both sides of the pipeline to a level at least 300mm above the crown of the pipes. as this material is placed and compacted in the trench, the supports to the sides of the trench shall be concurrently partly withdrawn so that there are no voids or uncompacted zones.

Except where otherwise specified or instructed by the engineer, no traffic load may be imposed upon the trench within 72 hours of the placing of the concrete cradle or surround.

If the contractor wishes to use any other method of laying pipes in concrete cradle or surround, he must submit his proposals in writing to and obtain the approval in writing from the engineer well in advance of the date when he wishes to perform the work.

SPECIAL FOUNDATION IN POOR SOIL

Where the formation of the trench is found to consist of material which is unstable to such a degree that in the opinion of the engineer, it cannot be removed and replaced with an approved material



thoroughly compacted in place to support the pipe properly, a suitable foundation for the pipes, consisting of piling, timbers or other materials shall be prepared by the contractor and as instructed by engineer.

INSPECTION OF PIPELINES

As soon as the pipeline has been completed from manhole to manhole the contractor shall run through the pipes both backwards and forwards a double disc or solid or closed cylinder 75 mm less in diameter than the internal diameter of pipes.

If as a result of the removal of any obstructions the engineer considers that damages may have been caused to the pipe lines, he shall be entitled to order the stretch to be tested immediately. should such test prove unsatisfactory, contractor shall make good the pipeline and carry out such further tests as are ordered by the engineer.

SITE TESTING

After laying & jointing of RCC pipes is completed the pipe line shall be tested. All equipment for testing shall be supplied by the contractor. damage during testing shall be contractor's responsibility and shall be rectified by him to the full satisfaction of the engineer. water for testing of pipeline shall be arranged by the contractor at his own cost.

After the joints have been checked by the engineer and before backfilling of the trenches, the entire section of the sewer shall be proved by the contractor to be watertight by filling the pipes with water to the level of 1.50m above the top of the highest pipe in the stretch and heading the water up for a period of one hour. the apparatus used for the purpose of testing shall be approved by engineer. the contractor if required by the engineer shall de-water the excavated pit and keep it dry during the period of testing. The loss of water over a period of 30 minutes shall be measured by adding water from a measuring vessel at regular 10 minutes intervals and noting the quantity required to maintain the original water level. for acceptance of the section of pipeline under test the average quantity added shall not exceed 1 litre/ hour/100 linear meters / 10mm of nominal internal diameter. any leakage including excessive sweating which causes a drop in the test water level in excess of the permitted amount will result in the pipeline being rejected. the contractor will be required to remove and re-lay the pipeline for re-testing.

Water used for the test shall be removed from pipes and not discharged to the excavated trenches.

1.17 Pressure Gauge

All pressure gauges shall be dial type with Borden tube element of SS 316. The dial size shall be of 150 mm diameter and scale division shall be in metric units marked clearly in black on a white dial. The range of pressure gauge shall be 0-10 kg.sq.cm or as specified in BOQ. The pressure gauges shall be complete with isolation cock, siphon tubing, etc.

1.18 Pressure Switches

The pressure switch shall be industrial type single pole double throw electric pressure switch designed for starting or stopping of equipment when the pressure in the system drops or exceeds pre set limits. It shall comprise of a single pole change over switch, below element assembly and differential spindle.

All pressure switches shall have ¼" BSP (F) inlet connection and screwed cable entry for fixing cable gland. All control cabling shall be provided.



1.19 Sprinkler Heads

Sprinkler heads shall be provided at approximate spacing so as to cover 12 sq.mtr. per sprinkler head in case of ordinary hazard & 17 sq.mtr. in case of light hazard. The spacing shall however be in uniformity with the drawings and properly coordinated with electrical fixtures, ventilation ducts and grilles and other services along the ceiling. Sprinkler heads shall be gunmetal quartz bulb type with a temperature rating of 68°C. Sprinkler heads shall be of upright conventional type with fusible link for operation. Sprinkler head shall be approved by the under writers Laboratories (U.L.) or Fire Officers Committee (FOC). The finish shall be as specified in bill of quantities.

Contractor shall install cabinet (fabricated from 16 Gauge M. S. sheets with lockable glass shutters. Shelves for keeping spare sprinklers and spanner at locations approved by the Engineer-in-Charge and given in the schedule of quantities. The contractor shall also give required tools for removing and fixing of different types of sprinkler free of cost as directed by Engineer-in-Charge.

1.20 Sprinkler System

General:

To supply, install, testing and commissioning of sprinkler system as per drawing and Sprinkler heads spacing shall be in conformity with the drawings and properly coordinated in reflected ceiling with electrical fixtures, ventilation ducts and grills and other services along the ceiling.

Sprinkler heads shall be brass / gunmetal with quartz bulb with temperature rating of 68 degree Celsius. Sprinkler heads shall be of type and quality approved by the local fire brigade authority/NFPA 13. The inlet shall be screwed. Sprinkler heads shall be pendent, recessed or special side type. All sprinklers shall conform to the specifications given by IS, NFPA, FOC, UL & FM.

Pendent /Upright Type Sprinkler Head

Sprinkler heads shall be quartzite bulb type with bulb, valve assembly, yoke and the deflector. The sprinkler shall be of approved make and type with 15 mm nominal diameter outlets.

The bulb shall be made of corrosion free material strong enough to withstand any water pressure likely to occur in the system. The bulb shall be shatter when the temperature of the surrounding air reaches at 68 c.

The nominal bore shall 15 mm diameter and color of liquid shall be as per temperature rating.

Concealed Type / With Rosette Sprinkler Head

Adjustable concealed sprinklers shall be provided as specified in S.O.Q. in areas where an attractive appearance is primary concern. Concealed Sprinkler heads shall be infinitely adjustable for a full 15 mm so as to compensate for uneven ceiling heights & allow adjustment of the sprinkler cover at any timer. The sprinkler shall be of approved make and type with 15 mm nominal diameter outlets.

The bulb shall be made of corrosion free material strong enough to withstand any water pressure likely to occur in the system. The bulb shall be shatter when the temperature of the surrounding air reaches at 68 c.

The nominal bore shall 15 mm diameter and color of liquid shall be as per temperature rating.

Installation Control Valve & Related Equipment's for Sprinkler System



The sprinkler system shall have installation control valve (Flow switch with Isolation Valve and Drain arrangement) along with assemblies at entry of main header in each floor.

Flow Switch

Flow switch shall have a paddle made up of flexible material of the width to fit within the pipe bore. The terminal box shall be mounted over the paddle / pipe through a connecting socket. The switch shall be potential free in either NO or NC position as required. The switch shall be able to trip and make/ break contact on the operation of a single sprinkler head. The terminal box shall have connections for wiring to the Fire alarm panel. The seat shall be of stainless steel. The flow switch shall have IP: 55 protections.

The flow switch shall work at a minimum flow rate of 100 LPM. Further, it shall have a retard to compensate for line leakage or intermittent flows.

Butterfly Valve

- a. The Butterfly valve shall be suitable for waterworks and tested to minimum of 16 kg/sq cm Pressure. The valves shall fulfill the requirements of BIS (Indian Standard) BS: 5155 or AWWA C 504, API 609 and MSS-SP-67.
- b. The body shall be of cast iron to IS: 210 in circular shape and of high strength to take the minimum water pressure of 10 kg/sq cm. The disc shall be heavy-duty cast iron with anti-Corrosive epoxy or nickel coating.
- c. The valve seat shall be high grade elastomeric or nitrile rubber. The valve in closed position shall have complete contact between the seat and the disc throughout the perimeter. The elastomeric rubber shall have a long life and shall not give away on continuous applied water pressure. The shaft shall be of ENB grade carbon steel.
- d. The valve shall be fitted between two flanges on either side of pipe flanges. The valve edge rubber shall be projected outside such that they are wedged within the pipe flanges to prevent leakages.
- e. The valve shall be supplied with manual gear operated opening/ closing system by lever.

Drain Valve

50 MM / or as specified in SOQ diameter MS/ G.I. pipe conforming to I.S.:1239 (heavy grade) with 50 mm diameter / or as specified in SOQ gunmetal full way valve shall be provided for drainage of any water in the system in low pockets.

SPRINKLER ALARM VALVE:

Apart from above, Sprinkler alarm valve shall be provided with all accessories for wet sprinkler system to ensure positive water flow. It shall have flange connection & shall have brass body & steel trims. The valve shall conform to the specifications given by NFPA/UL/LFA

1.21 Testing of the hydrant system:

All air shall be trapped from the pipeline through hydrants & air valves. Each section of the pipe shall be slowly filled with the water & allow to stand the water for 2 hours minimum with the ends closed. No joints / connection shall be leaked within this duration. The hydraulic test pressure shall be 1.5 times the design pressure.

Flushing of underground connections: Underground mains and lead-in connections to system risers shall be flushed before connections made to piping in order remove foreign materials which may have entered the underground during the course of installation. For hydrant system the flushing operation shall be continued until water is clear.

Underground mains and lead-in connection shall be flushed at a flow rate of not less than 480 ltrs. Per minute.

Provision shall be made for the disposal of water issuing from test outlets to avoid property damage

Acceptance Test



At the time of taking over, the hydrant system shall fulfill the following acceptance tests: -
Starting up of the pressure suction (Jockey Pump): The pressure switch shall be set at 3.5 kg/cm² at the lower limit and 7.5 kg/cm² at the upper limit. The system drain shall be opened to cause a drop in the pressure. The Jockey Pump shall start as soon as the pressure gauge needle falls down to 3.5 kg. The Jockey pump shall also stop automatically when the system has been pressurized again upto 7.5kg/cm².

The main electrical pump shall be set to start at 3.5 kg/cm². An external hydrant valve using a single length of hose and branch pipe shall be fully opened to cause a drop of pressure in the system. At first, the jockey pump shall start when the pressure drops from 7 kg. Further, drop in the pressure from 3.5 kg should be allowed to test automatic start-up of the electrical pump. The electrical pump shall continue to run at least for 5 minutes and register rise in the pressure up to 3.5 kg the Jockey Pump shall be automatically start at this. The electrical pump shall be stopped manually by pressuring the stop button.

After having the system got fully charged at 7.5 kg/cm² the external hydrant valve using hose and branch pipe at (ii) above shall be opened. When the pressure has dropped from 3.5 kg/cm², the electric main pump shall come into operation automatically. After the main pump has run for 5 minutes, the power supply in the pump house shall be switched off. The diesel pump shall automatically come into operation immediately.

All these tests mentioned above shall be repeated after one-hour interval. The result of all the tests shall be identical again. After the system has satisfactorily withstood the above tests, it can be taken over from the contractor.

1.22 Start-Up/System Testing

It will be the responsibility of the tendered to cause interim/stage inspection by the Local Fire Authority LFA/ Chief Fire Officer C.F.O during execution of the work as and when so called for by the Employer / Consultant and shall carry out any rectification / modification as may be suggested by the Local Fire Authority (LFA), Chief Fire Officer (CFO).

Soon after the work is completed, the contractor shall inform the LFA/CFO in writing with a copy to the Consultant/Employer for getting the complete system including all sub system and instrumentation, control etc. thoroughly inspected and tested for satisfactory performance. After satisfactory completion of tests of the systems by the LFA / CFO, the contractor shall be required to submit as built drawings to the Consultant / OWNER which have been so approved.

Commissioning of System

- a. Pressurized the fire hydrant system by running the main fire pump and after attain required pressure shut off the pump.
- b. Open bye-pass valve and allow the pressure to drop in the system. Check that the jockey pump cuts-in and cuts-out at the pre-set pressure. If necessary, adjust the pressure switch for the jockey pump. Close bye-pass valve.
- c. Open bye-pass valve and allow the water to flow into the fire water tank in order to avoid wastage of water. The main fire pump should cut-in at the preset pressure and should not cut-out automatically on reaching the normal line pressure. The main fire pump should stop only by manual push button. However, the jockey pump should cut out as soon as the main pump starts.
- d. Switch off the main fire pump and test check the diesel engine driven pump in the same manner as the electrically driven pump.
- e. When the fire pumps have been checked for satisfactory working on automatic controls, open fire hydrant simultaneously and allow the hose pipe to discharge water into the fire tank to avoid wastage. The electrically driven pump should run continuously for eight hours so that its performance can be checked.



- f. Diesel engine / DG set driven pump should also be checked in the same manner as given in Para above by running for 8 hours.
- g. Check each landing valve, male and female couplings and branch pipes for compatibility with each other. Any fitting which is found to be incompatible and does not fit into the other properly, shall be replaced by the Contractor. Landing valves shall also be checked by opening and closing under pressure.

Handing Over

- All commissioning and testing shall be done by the Contractor to the complete satisfaction of the Engineer-in-Charge / Consultants, and the job handed over to the Client.
- Contractor shall also hand over to the Client all maintenance and operation manuals and all items as per the terms of the contract

1.23 Technical Data Sheet

(Technical information to be furnished in following format by Bidder)

Technical Data Sheet To Be Furnished By Bidder

SR. NO.	SPECIFICATION	DESCRIPTION			
		HYDRANT	SPRINKLER	JOCKEY	WATER CURTAIN
1.0	FIRE PUMP(S)				
1.1	Type(s)				
1.2	Make(s)				
1.3	General Specifications:				
1.3.1	Capacity (Lit/Sec)				
1.3.2	Head in (mtr.)				
1.3.3	Sizes of suction and delivery pipes in mm				
1.3.4	Pump Efficiency				
1.4	Material for Impeller				
1.5	Material for Pump Casing				
1.6	Material for Shaft				
1.7	Electrical Motor				
1.7.1	Type				
1.7.2	Make				
1.7.3	Speed in R.P.M				
1.7.4	H.P and Voltage of driving motor, type of enclosure and class of winding insulation, Motor full load current (Remote controlled starting arrangement, if any)				
1.7.5	Details of electric supply				



SR. NO.	SPECIFICATION	DESCRIPTION			
1.7.6	Type of Starter				
1.8	Diesel engine (if asked)				
1.8.1	Speed and Horse power of the engine driving pump(s)				
1.8.2	Method of starting the engine				
1.8.3	Fuel Consumption				
1.8.4	Details of batteries, Battery Charger and Diesel Engine control panel				
1.8.5	Make				
2.0	HYDRANT MAINS				
2.1	Material & Type of underground and / or overhead mains with method of joining				
2.2	To what pressure have the pipes been tested?				
2.3	No. & dia. Of wet riser				
3.0	HYDRANT VALVES				
3.1	Type and Make				
3.2	No. & type of Yard hydrants valve				
3.3	No. & type of floor hydrants				
4.0	HOSE				
4.1	Material and diameter				
4.2	Manufacturer's Name and Guarantee for bursting pressure.				
4.3	No. of length of 15m and 7.5m respectively				
4.4	At what pressure the hose has been tested by the insured?				
4.5	Where is hose kept?				
4.6	No. of branch pipes and nozzles and their diameters				
5.0	SPRINKLER				
5.1	No. & type of isolation valves				
5.2	Type, make and fusing temperature of the sprinkler heads used.				

Note: Performance curve for pumps & catalogues for each above item shall be submitted

1.24 Installation of Engineered Support System

Hydrant and Sprinkler Pipe Support for RCC Slab

The Firefighting pipe should be simply suspended by Sprinkler Clamp having knurled nut.

The Sprinkler Clamp should be pre-galvanized with one-piece design for safe hanging of sprinkler pipes. It should have height adjustable arrangement so as to incorporate the suspended threaded rod.

The Mounting according to static requirements should undertake into account the manufacturer's documents and should be monitored according to VdS or UL /FM Approval.

The riser and hydrant / sprinkler pipe support installation should be as per National Building Code. The Riser Pipes should be mounted on the support channel with the help of a split clamps DIN 3567.



The support channel should be made up of cold rolled steel of quality DX51 or greater and as per EC3(Eurocode 3) or DIN EN 1993-1-1

The Support channel should be pre-galvanized with minimum GSM of 275 and should have universal mounting slot on the front of the rail for accurate positioning of fasteners and system compatible round and long holes on back of the rail.

The Mounting according to static requirements should undertake into account the manufacturer's documents and should be monitored according to RAL - GZ 655-C

The Threaded Rods used for the suspension of the Pipe should be made up of partially annealed medium carbon steel of grade 4.8 strength class and as per DIN 976 standard.

The Drop-in anchors used for the suspension of the rods should be ETA(EUROPEAN TECHNICAL APPROVAL) with CE mark for cracked and un-cracked concrete.

It should be divided into four expansion segments for uniform pressing force distribution in the borehole.

The load bearing capacity for the selection of the sprinkler clamp for suitable size of the pipe should be as per Vds and FM guideline provided by the contractor to the consultant for verification.

Maximum Support Spacing (m)					
Nominal Pipe Dia (mm)	Support Distance (M)	Nominal Pipe Dia (mm)	Support Distance (M)	Nominal Pipe Dia (mm)	Support Distance (M)
Upto 15	1.8	65	3.7	250	5.0
20	2.4	80	3.7	300	6.1
25	2.4	100	3.7	350	10.0
32	2.7	125	3.7	400	10.5
40	3.0	150	4.5	450	11.0
50	3.0	200	5.6	500	12.0

Typical Arrangement for sprinkler and hydrant pipe support From RCC slab

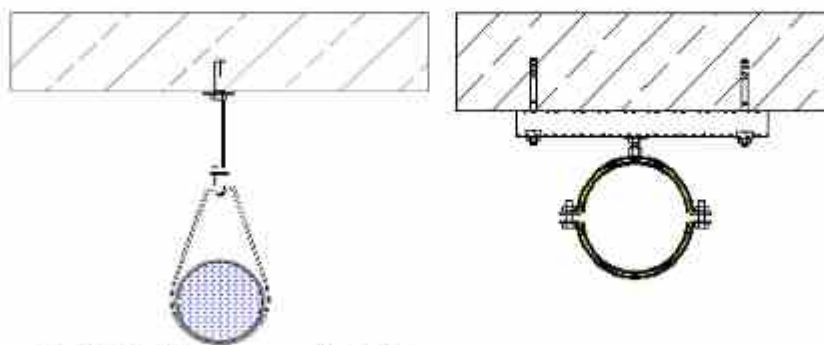

Hydrant and Sprinkler Pipe Support for PEB structure

The Firefighting pipe should be simply suspended by Sprinkler Clamp having knurled nut.

The Sprinkler Clamp should be pre-galvanized with one-piece design for safe hanging of sprinkler pipes. It should have height adjustable arrangement so as to incorporate the suspended threaded rod.

The Mounting according to static requirements should undertake into account the manufacturer's documents and should be monitored according to VdS or UL /FM Approval.



The riser and hydrant pipe support installation should be as per National Building Code.
The Riser Pipes should be mounted on the support channel with the help of split clamps DIN 3567.

The support channel should be made up of cold rolled steel of quality DX51 or greater and as per EC3 (Eurocode 3) or DIN EN 1993-1-1

The Support channel should be pre-galvanized with minimum GSM of 275 and should have universal mounting slot on the front of the rail for accurate positioning of fasteners and system compatible round and long holes on back of the rail.

The Mounting according to static requirements should undertake into account the manufacturer's documents and should be monitored according to RAL - GZ 655-C

The Threaded Rods used for the suspension of the Pipe should be made up of partially annealed medium carbon steel of grade 4.8 strength class and as per DIN 976 standard.

For parallel to beam application.

The Girder cleat for attachment of support channel to steel girder
Girder cleat should be Vds approved.
For perpendicular to beam application

The Girder clamp for suspension of threaded pins and threaded rods for support channels.
Girder clamps should be FM and Vds Approved.

The load bearing capacity for the selection of the sprinkler clamp for suitable size of the pipe should be as per Vds and FM guideline provided by the contractor to the consultant for verification.

Maximum Support Spacing (m)					
Nominal Pipe Dia (mm)	Support Distance (M)	Nominal Pipe Dia (mm)	Support Distance (M)	Nominal Pipe Dia (mm)	Support Distance (M)
Upto 15	1.8	65	3.7	250	5.0
20	2.4	80	3.7	300	6.1
25	2.4	100	3.7	350	10.0
32	2.7	125	3.7	400	10.5
40	3.0	150	4.5	450	11.0
50	3.0	200	5.6	500	12.0

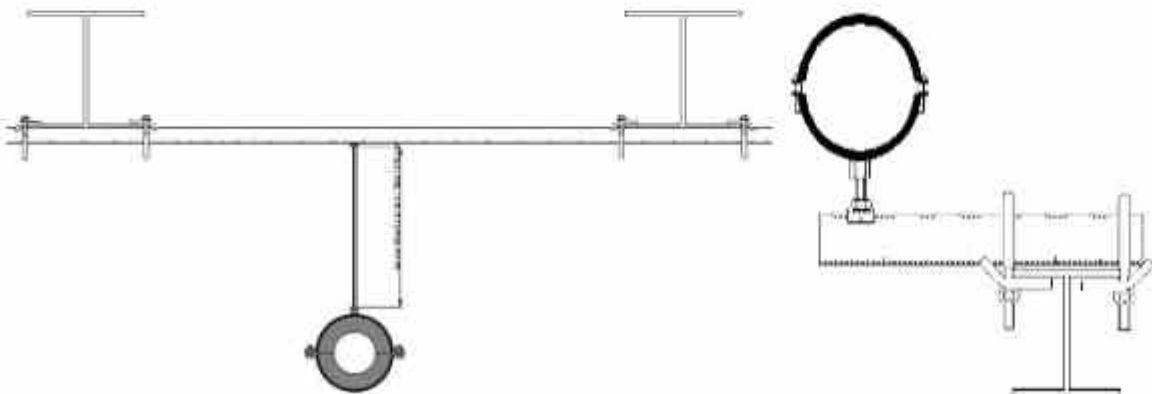

Hydrant Pipe Support for Building Shaft



The Riser Pipes should be mounted on the support channel with the help of a split clamps or STATO BRACKET.

The support channel should be made up of cold rolled steel of quality DX51 or greater and as per EC3(Eurocode 3) or DIN EN 1993-1-1

The riser and hydrant / sprinkler pipe support installation should be as per National Building Code. The Support channel should be pre-galvanised with minimum GSM of 275 and should have universal mounting slot on the front of the rail for accurate positioning of fasteners and system compatible round and long holes on back of the rail.

The Mounting according to static requirements should undertake into account the manufacturer's documents and should be monitored according to RAL, - GZ 655-C

The Threaded Rods used for fixing pipe clamp with support channel that should be made up of partially annealed medium carbon steel of grade 4.8 strength class and as per DIN 976 standard.

The Drop-in anchors used for fixing channel with building shaft that should be ETA(EUROPEAN TECHNICAL APPROVAL) with CE mark for cracked and un-cracked concrete.

It should be divided into four expansion segments for uniform pressing force distribution in the borehole.

The load bearing capacity for the selection of the sprinkler clamp for suitable size of the pipe should be as per Vds and FM guideline provided by the contractor to the consultant for verification.

Maximum Support Spacing (m)					
Nominal Pipe Dia (mm)	Support Distance (M)	Nominal Pipe Dia (mm)	Support Distance (M)	Nominal Pipe Dia (mm)	Support Distance (M)
Upto 15	1.8	65	3.7	250	5.0
20	2.4	80	3.7	300	6.1
25	2.4	100	3.7	350	10.0
32	2.7	125	3.7	400	10.5
40	3.0	150	4.5	450	11.0
50	3.0	200	5.6	500	12.0

Typical Arrangement for sprinkler and hydrant pipe support From PEB structure

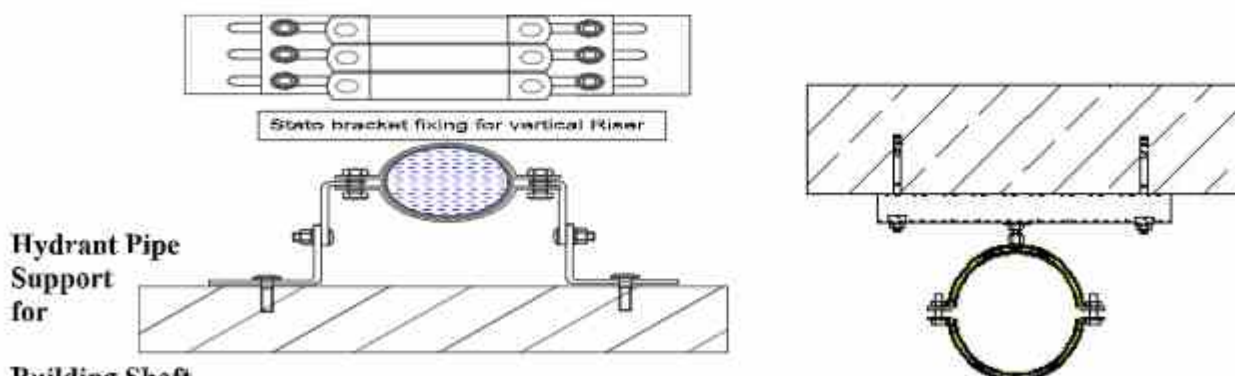

Building Shaft

The Riser Pipes should be mounted on the support channel with the help of a split clamps DIN 3567 or STATO BRACKET.

The support channel should be made up of cold rolled steel of quality DX51 or greater and as per EC3(Eurocode 3) or DIN EN 1993-1-1



The riser and hydrant / sprinkler pipe support installation should be as per National Building Code. The Support channel should be pre-galvanised with minimum GSM of 275 and should have universal mounting slot on the front of the rail for accurate positioning of fasteners and system compatible round and long holes on back of the rail.

The Mounting according to static requirements should undertake into account the manufacturer's documents and should be monitored according to RAL - GZ 655-C

The Threaded Rods used for fixing pipe clamp with support channel that should be made up of partially annealed medium carbon steel of grade 4.8 strength class and as per DIN 976 standard.

The Drop-in anchors used for fixing channel with building wall that should be ETA (EUROPEAN TECHNICAL APPROVAL) with CE mark for cracked and un-cracked concrete.

It should be divided into four expansion segments for uniform pressing force distribution in the borehole.

The load bearing capacity for the selection of the sprinkler clamp for suitable size of the pipe should be as per TDS and FM guidelines provided by the contractor to the consultant for verification.

Maximum Support Spacing (m)					
Nominal Pipe Dia (mm)	Support Distance (M)	Nominal Pipe Dia (mm)	Support Distance (M)	Nominal Pipe Dia (mm)	Support Distance (M)
Upto 15	1.8	65	3.7	250	5.0
20	2.4	80	3.7	300	6.1
25	2.4	100	3.7	350	10.0
32	2.7	125	3.7	400	10.5
40	3.0	150	4.5	450	11.0
50	3.0	200	5.6	500	12.0

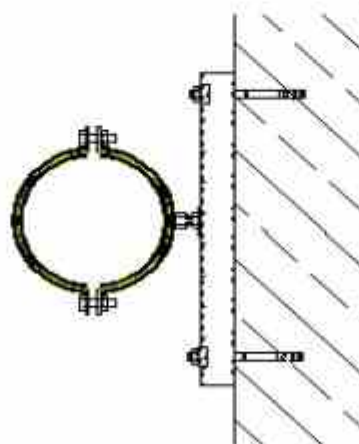

Hydrant and Sprinkler Pipe Support for RCC Slab

The Firefighting pipe should be simply suspended by Sprinkler Clamp having knurled nut.



The Sprinkler Clamp should be pre-galvanized with one-piece design for safe hanging of sprinkler pipes. It should have height adjustable arrangement so as to incorporate the suspended threaded rod.

The Mounting according to static requirements should undertake into account the manufacturer's documents and should be monitored according to VdS or UL /FM Approval.

The riser and hydrant / sprinkler pipe support installation should be as per National Building Code. The Riser Pipes should be mounted on the support channel with the help of a split clamps DIN 3567. The support channel should be made up of cold rolled steel of quality DX51 or greater and as per EC3(Eurocode 3) or DIN EN 1993-1-1

The Support channel should be pre-galvanized with minimum GSM of 275 and should have universal mounting slot on the front of the rail for accurate positioning of fasteners and system compatible round and long holes on back of the rail.

The Mounting according to static requirements should undertake into account the manufacturer's documents and should be monitored according to RAL - GZ 655-C

The Threaded Rods used for the suspension of the Pipe should be made up of partially annealed medium carbon steel of grade 4.8 strength class and as per DIN 976 standard.

The Drop-in anchors used for the suspension of the rods should be ETA(EUROPEAN TECHNICAL APPROVAL) with CE mark for cracked and un-cracked concrete.

It should be divided into four expansion segments for uniform pressing force distribution in the borehole.

The load bearing capacity for the selection of the sprinkler clamp for suitable size of the pipe should be as per Vds and FM guideline provided by the contractor to the consultant for verification.

Maximum Support Spacing (m)					
Nominal Pipe Dia (mm)	Support Distance (M)	Nominal Pipe Dia (mm)	Support Distance (M)	Nominal Pipe Dia (mm)	Support Distance (M)
Upto 15	1.8	65	3.7	250	5.0
20	2.4	80	3.7	300	6.1
25	2.4	100	3.7	350	10.0
32	2.7	125	3.7	400	10.5
40	3.0	150	4.5	450	11.0
50	3.0	200	5.6	500	12.0

Typical Arrangement for sprinkler and hydrant pipe support From RCC slab

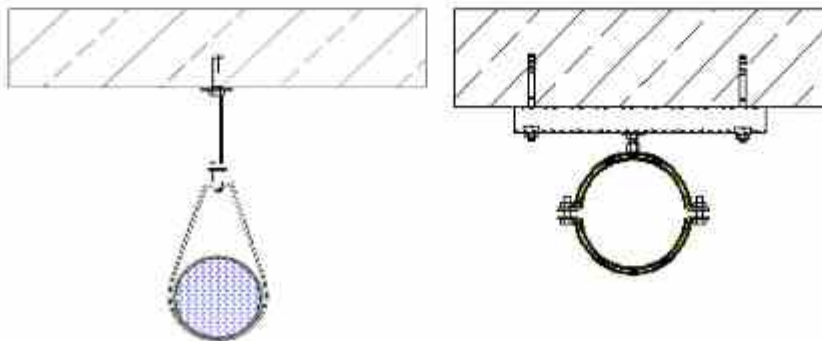

Hydrant and Sprinkler Pipe Support for PEB structure



The Firefighting pipe should be simply suspended by Sprinkler Clamp having knurled nut.

The Sprinkler Clamp should be pre-galvanized with one-piece design for safe hanging of sprinkler pipes. It should have height adjustable arrangement so as to incorporate the suspended threaded rod.

The Mounting according to static requirements should undertake into account the manufacturer's documents and should be monitored according to VdS or UL /FM Approval.

The riser and hydrant pipe support installation should be as per National Building Code.

The Riser Pipes should be mounted on the support channel with the help of a split clamps DIN 3567.

The support channel should be made up of cold rolled steel of quality DX51 or greater and as per EC3(Eurocode 3) or DIN EN 1993-1-1

The Support channel should be pre-galvanized with minimum GSM of 275 and should have universal mounting slot on the front of the rail for accurate positioning of fasteners and system compatible round and long holes on back of the rail.

The Mounting according to static requirements should undertake into account the manufacturer's documents and should be monitored according to RAL - GZ 655-C

The Threaded Rods used for the suspension of the Pipe should be made up of partially annealed medium carbon steel of grade 4.8 strength class and as per DIN 976 standard.

For parallel to beam application.

The Girder cleat for attachment of support channel to steel girder

Girder cleat should be Vds approved.

For perpendicular to beam application

The Girder clamp for suspension of threaded pins and threaded rods for support channels.

Girder clamps should be FM and Vds Approved.

The load bearing capacity for the selection of the sprinkler clamp for suitable size of the pipe should be as per Vds and FM guideline provided by the contractor to the consultant for verification.

Maximum Support Spacing (m)					
Nominal Pipe Dia (mm)	Support Distance (M)	Nominal Pipe Dia (mm)	Support Distance (M)	Nominal Pipe Dia (mm)	Support Distance (M)
Upto 15	1.8	65	3.7	250	5.0
20	2.4	80	3.7	300	6.1
25	2.4	100	3.7	350	10.0
32	2.7	125	3.7	400	10.5
40	3.0	150	4.5	450	11.0
50	3.0	200	5.6	500	12.0

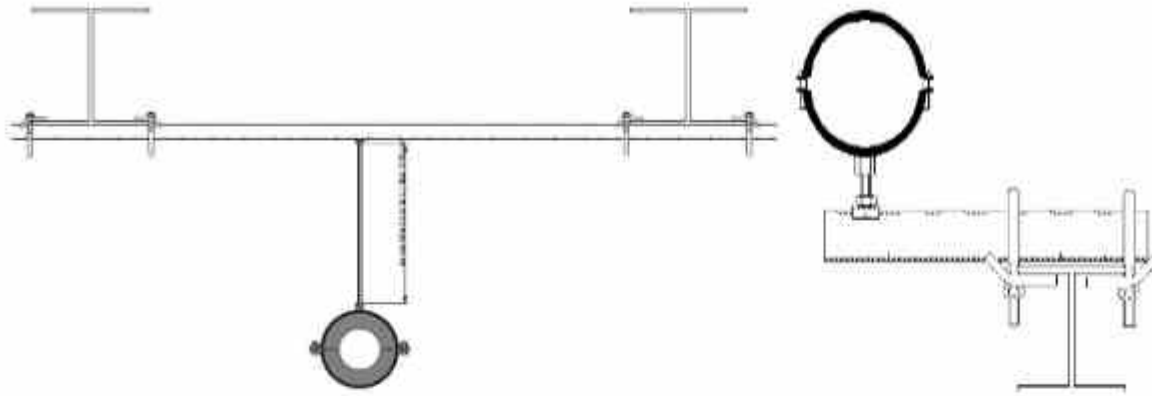

Hydrant Pipe Support for Building Shaft

The Riser Pipes should be mounted on the support channel with the help of a split clamps or STATO BRACKET.

The support channel should be made up of cold rolled steel of quality DX51 or greater and as per EC3(Eurocode 3) or DIN EN 1993-1-1

The riser and hydrant / sprinkler pipe support installation should be as per National Building Code. The Support channel should be pre-galvanised with minimum GSM of 275 and should have universal mounting slot on the front of the rail for accurate positioning of fasteners and system compatible round and long holes on back of the rail.

The Mounting according to static requirements should undertake into account the manufacturer's documents and should be monitored according to RAL - GZ 655-C

The Threaded Rods used for fixing pipe clamp with support channel that should be made up of partially annealed medium carbon steel of grade 4.8 strength class and as per DIN 976 standard.

The Drop-in anchors used for fixing channel with building shaft that should be ETA(EUROPEAN TECHNICAL APPROVAL) with CE mark for cracked and un-cracked concrete.

It should be divided into four expansion segments for uniform pressing force distribution in the borehole.

The load bearing capacity for the selection of the sprinkler clamp for suitable size of the pipe should be as per TDS and FM guidelines provided by the contractor to the consultant for verification.

Maximum Support Spacing (m)					
Nominal Pipe Dia (mm)	Support Distance (M)	Nominal Pipe Dia (mm)	Support Distance (M)	Nominal Pipe Dia (mm)	Support Distance (M)
Upto 15	1.8	65	3.7	250	5.0
20	2.4	80	3.7	300	6.1
25	2.4	100	3.7	350	10.0
32	2.7	125	3.7	400	10.5
40	3.0	150	4.5	450	11.0
50	3.0	200	5.6	500	12.0

Typical Arrangement for sprinkler and hydrant pipe support From PEB structure

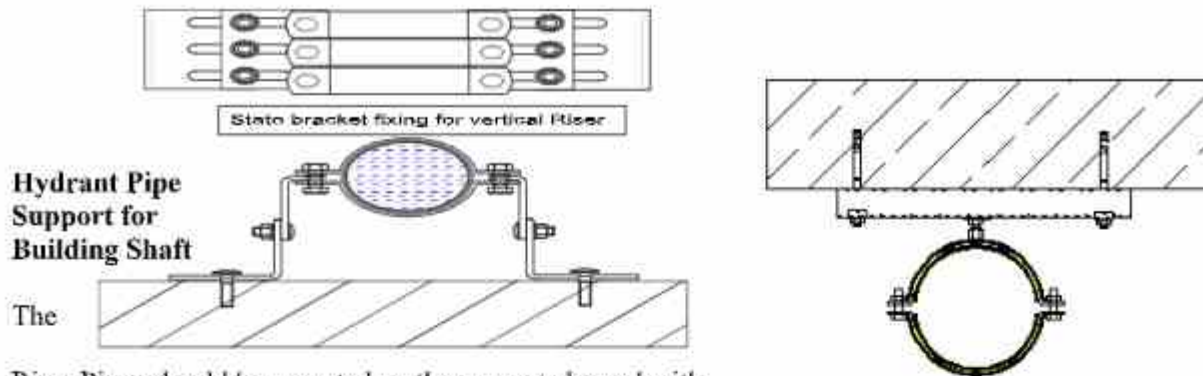

Riser Pipes should be mounted on the support channel with the help of a split clamps DIN 3567 or STATO BRACKET.

The support channel should be made up of cold rolled steel of quality DX51 or greater and as per EC3(Eurocode 3) or DIN EN 1993-1-1

The riser and hydrant / sprinkler pipe support installation should be as per National Building Code. The Support channel should be pre-galvanized with minimum GSM of 275 and should have universal mounting slot on the front of the rail for accurate positioning of fasteners and system compatible round and long holes on back of the rail.

The Mounting according to static requirements should undertake into account the manufacturer's documents and should be monitored according to RAL - GZ 655-C

The Threaded Rods used for fixing pipe clamp with support channel that should be made up of partially annealed medium carbon steel of grade 4.8 strength class and as per DIN 976 standard.

The Drop-in anchors used for fixing channel with building wall that should be ETA(EUROPEAN TECHNICAL APPROVAL) with CE mark for cracked and un-cracked concrete. It should be divided into four expansion segments for uniform pressing force distribution in the borehole.

The load bearing capacity for the selection of the sprinkler clamp for suitable size of the pipe should be as per TDS and FM guidelines provided by the contractor to the consultant for verification.

Maximum Support Spacing (m)					
Nominal Pipe Dia (mm)	Support Distance (M)	Nominal Pipe Dia (mm)	Support Distance (M)	Nominal Pipe Dia (mm)	Support Distance (M)
Upto 15	1.8	65	3.7	250	5.0
20	2.4	80	3.7	300	6.1
25	2.4	100	3.7	350	10.0
32	2.7	125	3.7	400	10.5
40	3.0	150	4.5	450	11.0
50	3.0	200	5.6	500	12.0

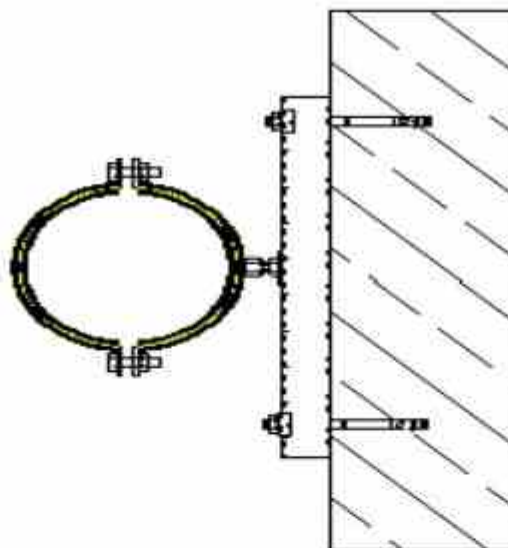

1.25 Fire Bucket:

Galvanized mild steel fire bucket with ISI mark as per IS 2546-1974. The shape and the essential dimensions of fire bucket shall conform to IS 2546-1974. fire buckets (3 nos./set) of 24-gauge galvanized steel sheet, standard 9 litre capacity and of round bottom shape, painted white inside and black on the bottom, inscribed with letters " FIRE" in black and gold with dry clean fire sand. The scope shall also include the stand for mounting the sand bucket.

MANUFACTURE

Body — The body shall be in two halves which shall be joined together by butt welding. The top rim of the body shall be wired and uniformly beaded. The beading shall be fully formed without gaps. The thickness of body shall be 1 mm and diameter of beading wire 3.55 mm

Bottom — The bottom shall be dished and shall be joined to the body by butt welding so that there is no raw edge or crevice on the inside of the bucket. The thickness of the bottom sheet shall be 1 mm.

Ears — The ears shall be made of mild steel sheet and shall be fitted to the body at the top by means of welding with the flat head on the side. The thickness of sheet for ears shall be 2.8 mm

Top Handle — The top handle shall be of mild steel rod of 10 mm in diameter with its ends bent up.

Bottom Handle — The bottom handle shall be of mild steel rod of 10 mm in diameter and it shall be joined to the bottom by welding as shown in Fig. 1. The grip shall have no sharp edges.

General — All gas welds shall be free from porosity, blow holes and brittleness.

FINISH

- All parts of the bucket shall be finished smooth and sharp edges rounded off.
- The bucket shall be galvanized after manufacture as per IS : 2629-1966*. The thickness of coating of zinc conforming to IS: 13229-1991 Specification for zinc for galvanizing on any portion shall be not less than 0.06 g/cm² (both sides inclusive). Alternately, it may also be galvanized of lead tin alloy to a thickness of not less than 0.012 mm.
- Bucket shall, in addition to galvanizing, be painted with two coats of white paint on the inside and two coats of red paint on the outside (see also 2.4). The handles and the ears shall be painted with two coats of black paint.
- The word 'FIRE' shall be painted in black centrally on the outside; its letters shall be 75 mm high, and approximately 12 mm thick.



1.26 Gunmetal orifice plates:

Specially designed gunmetal orifice plates (minimum 8 mm plate thickness) on hydrant outlets of landing valves including distant pieces of suitable size for reducing delivery pressure up to 3.5 kg/sq.cm at hydrant valve, as required by LFA complete with necessary accessories, etc.

Scope:

Supplying and erecting one no Brass orifice plate having 6 mm. thick with specified outer diameter and suitable inner diameter to reduce the pressure as per requirement.

Material:

Body: Gunmetal 8 mm thick

Method of construction: The orifice plate shall be placed before the hydrant valve.

Mode of Measurement:

Executed quantity shall be measured on number basis

1.27 Air release valve:

Scope:

Supplying and erecting Air release cock 25 mm dia made from gunmetal with necessary G.I. coupling for fixing on top of air vessel or on wet riser with 25 mm dia ball valve on inlet side and pressure gauge with isolating cock.

Material:

Air release valve: Gun metal

Coupling: G.I

Method of Construction:

Air release valve with necessary GI coupling shall be fixed on top of wet riser with required labour, tools, etc.

Mode of Measurement:

Executed quantity shall be measured on number basis.

Signages:

Providing & Fixing AUTOGLOW Signages in Block / Small Letters of Specified Sizes in BOQ. Signages shall be as per IS 12349-1988. The colour red, green and yellow, shall conform to Shade No. 536, 221 and 309 of IS: 5-1978. Colours for ready mixed paints and enamels (third revision) respectively. The paint shall conform to IS: 2932-1974 'Specification for enamel, synthetic, exterior (a) undercoating, (b) finishing (first revision).

1.28 Reflux Valve (Non-Return Valve)

Specifications shall conform to IS – 5312 or its latest update.

MATERIALS - The materials used for the manufacture of different component parts shall conform to the requirements given in IS 5312 – 2004 or its latest update.

Materials of Construction

Sr. No.	Component	Material
(a)	Body, cover, door, bearing holder and Doors/Disc/Plate	Grey Cast Iron ; IS 210 Gr. FG 260
(b)	Hinge Pin/ Door Pin and Door Suspension pin	Stainless steel; IS 6603



(c)	Body Seat rings	Leaded tin bronze, IS 318
(d)	Door Face ring	Leaded tin bronze
(e)	Bearing Bushes / Bearing Block	Leaded tin bronze
(f)	Plugs for hinge pin/ Air release plug	Leaded tin bronze
(g)	Bolts	Carbon Steel, IS 1363
(h)	Nuts	Carbon Steel, IS 1363
(i)	Gaskets	Rubber, IS 638
(j)	Hinges	Grey Cast Iron, IS 10

DESIGN AND MANUFACTURE -

Body - The body may be made in two parts - inlet shell and outlet shell. The inlet shell shall have duck foot support.

Diaphragm - Diaphragm shall be fitted between inlet and outlet shells. The parts in the diaphragm should be so designed as to induce minimum headloss in the flow through the valve.

Water Way Area - The area of the waterway through the multi- doors in the diaphragm shall not be less than the bore area except that this area may be reduced by not more than 15 percent for any proprietary designs.

Inlet and Outlet Shell Connections - The attachment of the inlet to outlet shell of the body shall be adequate to withstand the appropriate test pressures, service conditions and the mechanical loads encountered in the operation. All valves shall have bolted connection. Size of the bolts or studs shall not be less than 22 mm.

Seats - Seat rings shall be so fitted as to avoid their becoming loose in service. Standard countersunk screws shall not be used. 6.6 Door - The door shall be integral with the hinge and shall have a flat seating face.

Lugs - Suspension lugs shall be cast integrally on the diaphragm plate and shall be of adequate strength.

Number of Doors - The minimum number of doors (discs) in the diaphragm plate shall be two.

By-Pass Connection - By-passes are not standard items on valves to the design, but if required, it is recommended that they shall be made for connection between the inlet and outlet shell of the valve. By-passes shall conform to PN 1 of IS : 780-1984* and the minimum size of the by-pass arrangement shall be as indicated in respective IS.

COATING - All coatings shall be carried out after satisfactory testing of the valves prior to dispatch. All the un-machined ferrous surfaces of the valve (both inside and outside) shall be thoroughly clean, dry and shall be free from rust and grease before painting. All exposed machined ferrous surfaces shall be painted with one coat of aluminum red oxide primer. Two coats of black Japan conforming to Type B of IS 341 or paint conforming to IS9862 or IS2932 shall be applied by brush or spray for exterior application in colour as approved by the purchaser.

TESTING – Each valve shall be subjected to following hydrostatic tests as specified in IS.

- Hydrostatic Body Test
- Hydrostatic Seat Test



INSPECTION – The purchaser or his authorized representative shall have free access to the works of the manufacturer at all reasonable times to inspect the valve at any stage of manufacture and to reject any material which does not conform to the specified requirements.

MARKING – Following information shall be cast on each valve body in raised letter)

- a) Manufacturer's name or trade-mark;
- b) Nominal pressure of valve (PN1.0 or PN1.6);
- c) Size of valve, mm;
- d) Direction of flow; and
- e) Heat No. of cast.

BIS Certification Marking – Each valve may also be marked with the Standard Mark.

Lowering and jointing in position

Supply of Material

- a. Cast iron double-flanged valves with two tailpieces suitable to pipe conforming to the latest relevant IS shall be supplied and carted by the contractor to the site of work including loading, unloading and stacking at site.
- b. The valves and tailpieces shall be examined before laying for cracks and other flaws. They shall be undamaged in all respect.
- c. The valves shall be cleaned before laying.
- d. All grits and foreign materials shall be removed from the inside of the valves before placing.
- e. All the four faces shall be thoroughly cleaned and coated with a thin layer of mineral grease.
- f. The tightening of gland shall be checked with a pair of inside-calipers. Clearance between the top of stuffing box and the underside of the gland shall be uniform all the sides.

Jointing Material

- a. The contractor shall provide all necessary jointing materials such as nuts bolts, rubber packing, white zinc, jute, lead wool etc.
- b. All tools and instruments, which are to be required for installation of sluice valve shall be provided by the contractor.
- c. All jointing materials shall be got approved from the engineer-in-charge before use.
- d. The nuts and bolts shall conform to the relevant IS.
- e. The rubber packing shall conform all specifications as narrated in respective IS.

Installation

- a. The valve shall be lowered in to the trench carefully, so that no part is damaged during lowering operation.
- b. If necessary tailpieces shall be fitted with sluice valve first outside the trench and then lowered in to the trench.



- c. The rubber packing shall be three ply and of approved thickness. The packing shall be of full diameter of the flange with necessary holes and the sluice valve bore. It shall be even at both the inner and outer edges.
- d. The flange faces thoroughly greased.
- e. If flange faces are not free, the contractor shall use thin fibers of lead wool.
- f. After placing the packing, nuts and bolts shall be inserted and tightened to make the joint.
- g. The valve shall be tightly closed when being installed to prevent any foreign materials from getting in between the working parts of the valve.
- h. Each flange bolt shall be tightened a little at a time taking care to tighten diametrically opposite bolts alternatively.
- i. The valve shall be installed in such a way that its Spindle shall remain in truly vertical position.
- j. The otherend of tailpiece shall be fitted with pipes so that continuous lines can work.
- k. Extra excavation required for facility of lowering and fixing valve shall not be paid for.

Testing

- a. After installation of valve the same is tested to 1½ times of its test pressure or as specified in the IS.
- b. The joints of valve shall withstand the test pressure of pipelines.
- c. Defects noticed during test and operation of valve shall be rectified by the contractor at his own cost without any extra claim to the entire satisfaction of the Engineer-in-charge.

Measurement and payment:

The rate shall be paid as per Schedule of Payment per number of valves fixed and tested as directed.

1.29 Air vessel:

Scope

Supplying and installing Air vessel of 600 mm dia 2.0 meter. In height M.S. Tank fabricated from M.S. Black ERW pipe, conforming to IS 3589, having 6 mm thickness, dish end at both ends, duly welded with 300 mm dia pipe, having inlet of 100 mm dia, duly fitted with 100 dia sluice valve and 20/25 mm dia draw in with G.M. gate valve to be installed inside pump house along with provided M.S, angle tripod.

Material:

Air Vessel: MS ERW pipe confirming to IS 3589

Tripod: MS angle of size 75 X 75 X 5mm

Method of construction



300mm dia, 1.5meter height air vessel, Gate valve, flanges, MS angle Tripod including necessary labour, and use of required tools and plants

1.30 Strainer:

Y-Type Strainers with ISI marked are used for filtering out the dirt, rust, and other debris in the water flow protecting the piping equipment such as pumps, meters, valves, and other equipment in the piping system. All strainers are equipped with a retainer cap which allows easy access to the stainless steel screen for cleaning. Y-Type Strainer flanges are Ductile Iron ANSI B16.1, Class 125, with a maximum water working pressure of 300 psi (20.7 bar). ANSI B16.42, Class 125 flanges are not compatible with ANSI Class 250 or Class 300 flanges.

BODY Ductile iron conforming to ASTM A-536, Grade 65-45-12

SCREEN AISI 304

COATING Fusion Bond Epoxy Coating (RAL 3000)

APPROVALS UL Listed

MODEL Flanged Type: YSF Grooved Type: YSG (Refer Table-I)

WEIGHT Refer Table-II

1.31 Expansion Bellow:

SCOPE:

Design, fabrication, testing and installation of ISI marked metallic expansion bellows with necessary hardware to be provided at suction & delivery side of each pump and on header or as per drawing.

GENERAL:

Expansion bellows shall be designed as per the details furnished in the data sheet and shall be in accordance with the EJMA / ASME standard. All expansion bellows shall be free from dirt, moisture, grease, oil, etc. and all reports for hydrostatic test shall be furnished. Fatigue life expectancy to be considered for the bellows is 7000 cycles.

The bellows shall be metallic corrugated design and shall have double flange. The material for Bellows shall be SS 304.

CLEANING:

Prior to factory inspection, all manufacturing waste such as metal chips debris and all other foreign material shall be removed from interior of bellows. All mill scale, rust, oil, grease, chalk and all other deleterious material shall be removed from the interior and exterior surfaces.

PAINTING:

Bellows shall first be given two coats of zinc base primer after completely cleaning the surface and then it shall be coated with three coats of coal tar epoxy paint. The resulting coating shall be uniform and smooth and shall adhere perfectly to the surface.

Bellows used in pipes carrying water, the inside coating shall not contain any constituent soluble in water or any ingredient which could impart any taste or odour to the water.

TESTS AND INSPECTION:

1. Bellows shall be tested as per the relevant Standards with latest revisions.
2. Bellows shall be offered for visual inspection and dimensional checks.



3. The hydrostatic and water tightness testing shall be witnessed by the Client.

TENDER DRAWINGS:

The Dimensional drawings with material of construction shall be submitted by tenderer along with their offer.

1.32 Ball Valves:

Forged Brass Ball Valves (For cold/Hot Water)

SCOPE

The item includes provision of forged brass ball valves with hard chrome plated steel ball tested to a pressure not less than 15 kg/cm² with threaded or flanged joints including fixing and testing.

MATERIAL

All ball valves shall be heavy duty of approved make.

Valves shall have suitable for pressure of PN 15.

Ball valves up to 80 mm shall have forged brass body, SS spindle & Teflon seat rings.

Ball valve shall conform to IS: 9890 or BS: 1868.

Full way lever operated forged brass ball of brass body with forged brass hard chrome plated steel ball tested to a pressure not less than 15 kg/cm² with threaded or flanged joints. The weight of the full way valve shall be as per the table given below with a tolerance of 5 percent. For Hot water the same shall be suitable for temperature upto 85° C.

The valves shall have either screwed ends or flanged ends.

Diameter in mm	Flanged arch (Kg)	Screwed arch (Kg)
15	1.021	0.567
20	1.503	0.680
25	2.495	1.077
32	3.232	1.559
40	4.082	2.268
50	6.691	3.232
65	10.149	6.804
80	13.381	8.845

FIXING

- The valves shall be fixed in position in the pipeline as shown in the drawing or as directed with necessary socket or union, nuts, flanges, hardware, gaskets, tail piece, etc.
- During installation, flow direction on the valve shall be checked.
- Valves shall be preferably installed in horizontal position with adequate supports.

TESTING

The valves shall be body & seat tested at manufacturer’s works as per the relevant standard & duly stamped. Test certificate shall be submitted for material & hydraulic testing.

After fixing in the pipelines, the system shall be hydraulically tested for 1.5 times working pressure or 22.5 kg/cm² whichever is higher for minimum 4 hrs without any pressure drop. In case of leakage, contractor shall rectify/replace valves at his own cost

Valves shall also be tested for its hand wheel / lever function by frequent on-off operation.

1.33 MCC For Fire Pumps:

Design, manufacture, supply, installation, testing and commissioning of star delta starter control panels suitable for 415V, 3 phase, 4 wire, 50 hz power distribution system. The control panel shall consist of the respective Breaker, contactor, Overload relay and other required components to finish satisfactory work. Control panel should be communicated with pressure switch. Necessary integration between control panel and pressure switch shall be part of scope. All components in the control panel



shall be as per type 2 coordination of respective OEM. (Cost of wiring with pressure switches / switching on and switching off the pumps locally and remotely as per the drawing and as per local CFO requirement).

Cubicle type switchboards and components shall conform to the requirements of the latest revision including amendments of the following codes and standards.

- IS: 8623 Specification for factory-built assemblies of switchgear and control gear for voltage up to and including 1000V AC / 1200V DC.
- IS: 4237 General requirements for switchgear and control-gear for voltage not exceeding 1000-V.
- IS: 2147 Degree of protection provided by enclosure for low voltage switch gear and control-gear.
- IS: 1018 Switchgear and control-gear selection/installation and maintenance.
- IS: 6005 Code of Practice for phosphate of iron and steel.
- IS: 13947-2004/ IEC 947 – 1989 Air circuit breaker / molded case circuit breaker.
- IS: 1248 Direct acting indicating analogue electrical measuring instruments and testing accessories.
- IS: 2705 Part - I, II & III 1964 Current transformers for metering and protection with classification burden ad insulation.
- IEC/EN 60947-2 Motor Protection Circuit Breaker

1.34 Cable Gland, Lugs, XLPE Armoured Cable:

Scope of Work

This section shall cover supply, laying, testing and commissioning of medium voltage XLPE cables.

This specification gives the general requirement of cables. However, it is the responsibility of the vendor to take the joint measurement and obtain client's approval before the placement of orders to the main supplier / manufacturer.

- Codes & Standards

The following standards and rules shall be applicable:

Item No	Item	Relevant IS	Relevant IEC
1	XLPE insulated electric cables (heavy duty).	IS : 7098 Part I	
2	Recommended current ratings for cables.	IS : 3961	
3	Aluminium conductors for insulated cables	IS : 8130	Indian Electricity Act and Rules.

- Design Basis & Site Conditions

All equipment and materials will be selected and rated for use as per site conditions.



- Technical Requirements
- General Constructional Features

The medium voltage cables shall be supplied, laid, connected, tested and commissioned in accordance with the drawings, specifications, relevant Indian Standards specifications, manufacturer's instructions. The cables shall be delivered at site in original drums with manufacturer's name, size, and type, clearly written on the drums

- Material

Medium voltage cable shall be XLPE insulated, PVC sheathed, aluminum or copper conductor, armoured conforming to IS: 7098 Part I.

a) Type

The cables shall be circular, multi core, annealed copper or aluminum conductor, XLPE insulated and PVC sheathed, armoured or unarmoured.

b) Conductor

Uncoated, annealed copper / aluminum, of high conductivity up to 4mm.² size, the conductor shall be solid and above 4mm.², conductors shall be concentrically stranded as per IEC: 228.

c) Insulation

XLPE rated 70° c. extruded insulation

d) Core Identification

Two core	:	Red and Black
Three core	:	Red, Yellow and Blue
Four core	:	Red, Yellow, Blue and Black
Single core	:	Green, Yellow for earthing

Black shall always be used for neutral.

e) Assembly

Two, three or four insulated conductors shall be laid up, filled with non-hygroscopic material and covered with an additional layer of thermoplastic material.

f) Armour

Galvanized steel flat strip / round wires applied helically in single layers complete with covering the assembly of cores.

For cable size up to 25 Sq. mm. : Armour of 1.4 mm dia G.I. round wire

For cable size above 25 Sq. mm. : Armour of 4 mm wide 0.8 mm thick G.I strip

g) Sheath

XLPE 70 deg.c. rated extruded.

Inner sheath shall be extruded type and shall be compatible with the insulation provided for the cables.



The outer sheath shall be of an extruded type layer of suitable PVC material compatible with the specified ambient temp. 50 deg. C and operating temperature of cables. The sheath shall be resistant to water, ultraviolet radiation, fungus, termite, and rodent attacks. The color of the outer sheath shall be black, it should conform water swellable coating tape which should protect against saline water.

Sequential length marking required at every 1.0 mtr. interval on outer sheath Vendor has to furnish resistance / reactance / capacitances of the cable

a) Rating: Up to and including 1100 Volts.

- Drawings & Information

Contractor shall submit the as built drawing of the cable laying drawing.

Handing over Documents

The supplier shall submit following:

1. Data sheet indicating results of tests
2. Test reports

- Inspection and Testing

All cables shall be adequately protected against any risk of mechanical damage to which they may be liable in normal conditions of handling during transportation, loading, unloading etc.

The cable shall be supplied in single length i.e. Without any intermediate joint or cut unless specifically approved by the client.

The cable ends shall be suitably sealed against entry of moisture, dust, water etc. with cable compound as per standard practice.

Finished Cable Tests at Manufacturer's Works

The finished cables shall be tested at manufacturer's works. Following routine tests for each and every length of cable and copy of test results shall be furnished for each length of cable along with supply. If specified, the cables shall be tested in presence of client's representative.

a) Voltage Test

Each core of cable shall be tested at room temperature at 3 KV A.C. R.M.S. for duration of 5 minutes.

b) Conductor Resistance Test

The D.C. Resistance of each conductor shall be measured at room temperature and the results shall be corrected to 20° c. to check the compliance with the values specified in IS 8130 - 1976.

Cable Test Before and After Laying of Cables at Site

a) Insulation Resistance test between phases and phase to Neutral and phase to earth.

b) Continuity test of all the phases, neutral and earth continuity conductor.

c) Sheathing continuity test.

d) Earth resistance test of all the phases and neutral.

e)

Method of Measurement



The cables will be measured in meters. The unit rate shall include cutting the cable into required lengths, packing, loading, unloading, insurance, transportation, delivery to stores/site as per work order, stocking in stores, testing of cables at stores etc. of medium voltage cable. Total quantity in meters shall be measured lug to lug basis.

Transport, Delivery and Storage

The cable shall be supplied in the actual length as per detailed purchase order.

The cable shall be dispatched at client's stores or at site as per detailed instructions given by client at later stage.

The cable shall be loaded from the main vendor's store and properly stacked as per instruction of client's local representative. All such labour and transportation charges shall be clearly mentioned in the offer.

- Guarantee of Performance.

The quotes values of parameters shall be within given tolerance for given period of service life.

INSTALLATION OF CABLE NETWORK:

Cable network shall include power, control and lighting cables which shall be laid in underground trenches, hume pipe open trenches, cable trays, G.I. pipes, or on building structures as detailed in the relevant drawings, cable schedules or as per the client / consultant's instructions. Supply & installation of cable trays, G.I. pipes / conduits, cable glands and sockets of both end isolators, junction boxes, remote push button stations, etc. shall be under the scope of the contractor.

General requirements for handling cables:

- Before laying cables, this shall be tested for physical damage, continuity, absence of cross phasing, insulation resistance to earth and between conductors. Insulation resistance tests shall be carried out with 500 / 1000 V megger.
- The cables shall be supplied at site, wound on wooden drums as far as possible. For smaller length and sizes, cables in properly coiled form can be accepted. The cables shall be laid by mounting the drum of the cable on drum carriage. Where the carriage is not available, the drum shall be mounted on a properly supported axle, and the cable laid out from the top of the drum. In no case the cable will be rolled on as it produces kinks which may damage the conductor.
- Sharp bending of cable shall be avoided. The bending radius for PVC insulated and sheathed, armoured cable shall not be less than 10 D, where "D" is overall diameter of the cable.
- While drawing cables through G.I. pipes, conduits, RCC pipes, ensure that size of pipe is such that, after drawing cables, 40% area is free. After drawing cables, the end of pipe shall be sealed with cotton / bituminous compound.
- High voltage (11 KV and above), medium voltage (240 V and above) and other control cables shall be separated from each other by adequate spacing or running through independent pipes / trays.



- Armoured cables shall never be concealed in walls / floors / roads without G.I. pipes, conduits or RCC pipes.
- Joints in the cable throughout its length of laying shall be avoided as far as possible and if unavoidable, prior approval of site engineer shall be taken. If allowed, proper straight through epoxy resin tight joint shall be made, without any additional cost.
- A minimum loop of 3 mtr. shall be provided on both ends of the cable, and on both ends of straight through cable joint. This additional length shall be used for fresh termination in future. Cable for this loop shall be paid for supply and laying.
- Cable shall be neatly arranged in the trenches / trays in such manner so that criss-crossing is avoided and final take off to the motor / switchgear is facilitated. Arrangement of cable within the trenches / trays shall be the responsibility of the contractor.
- All cable routes shall be carefully measured and cable cut to the required lengths and undue wastage of cables to be avoided. The routes indicated in the drawings is indicative only and the same may be rechecked with the client / consultant before cutting of cables. While selecting cable routes interference with structures, foundations, pipelines, future expansion of buildings etc. should be avoided.
- All temporary ends of cables must be protected against dirt and moisture to prevent damage to the insulation. For this purpose, ends of all PVC insulated cables shall be taped with an approved PVC or rubber insulating tapes. Use of friction type or other fabric type tape is not permitted. Lead sheathed cables shall be plumbed with lead alloy.
- Wherever cable rises from underground / concrete / masonry trenches to motors / switchgears / push buttons, these shall be taken in G.I. pipes of suitable size, for mechanical protection up to 300 mm. distance of concerned cable gland or as instructed by the client / consultant.
- The cable pass through foundation / walls of other underground structures, the necessary ducts for opening will be provided in advance for the same. However, should it become necessary to cut holes in existing foundation of structures the electrical contractor shall determine the location and obtain approval of the client / consultant before cutting is done.

LAYING OF CABLES (UNDERGROUND SYSTEM)

Cables shall be so laid in trench that this will not interfere with other underground structure. All water pipes, sewage lines or other structures which become exposed by excavation shall be properly supported and protected from injury until the filling has been rammed solidly in places under and around them. Any telephone or other cables coming in the way are to be properly shielded / diverted as directed by the owner / consultant.

- Cable shall be laid at minimum depth of 750 mm. in case of L.T. and 1200 mm. in case of H.T. from ground level. Excavation will be generally in ordinary alluvial soil. The width of trench shall be sufficient for laying of required no. of cables.
- Sand bedding 75 mm. thick shall be made below and above the cables. Layer of bricks (full size) shall be laid above sand bedding on the sides and above the of cables



to cover cable completely. More than one cable can be laid in the same trench by providing a brick on edge between two cables. However, the relative location of cables in trench shall be maintained till termination. The surface of the ground after back filling the earth shall be made good so as to conform in all respects to the surrounded ground and to the entire satisfaction of the client / consultant.

- For all underground cables, route markers should be used :
 - a) Separate route markers should be used for LT, HT and telephone cables.
 - b) Route markers should be grounded in ground with 1:2:4 cement concrete pedestal size 230 x 230 x 300 mm.
 - b) Cable markers should be installed at an interval not exceeding 30 mtr. along the straight routes of cables at a distance of 0.5 mtr. away from centre of cable with the arrow marked on the cable markers plate indicating the location of cable. Cable markers should also be used to identify change in direction of cable route and for location of every joint in underground cable.
- RCC hume pipe for crossing road in cable laying shall be provided by employer. No deduction shall be made for cable laying in hume pipe for not providing bricks, sand and excavation. RCC hump pipe at the ends shall be sealed by bituminous compound after laying and testing of cables by electrical contractor without any extra charge.

LAYING OF CABLE IN MASONRY TRENCHES

- Masonry / concrete trenches for laying of cables shall be provided by employer. However, steel members such as M.S. angles / flats etc. shall be provided and grouted by electrical contractor to support the cables without any extra charge. Cables shall be clamped to these supports with minimum saddles / clamps. More than one tier of cables can be provided in the same trench if the no. of cables are more.
- Entry of cables in trenches shall be sealed with bituminous MASTIC compound to stop entry of water in trenches.

LAYING OF CABLES IN CABLE TRAYS

- Cable trays and steel members such as M.S. angle / channel / flats etc. shall be provided and fixed by the erector.
- Cable shall be fixed in cable trays in single tier formation and cables shall be clamped with aluminum flat clamps and galvanized bolts / nuts.
- Earthing flat / wire can also be laid in cable tray along with cables.
- After laying of cables, minimum 20% area shall be spare.

TERMINATION AND JOINTING OF CABLES

- a) For HT cables suitable size of Raychem termination kit shall be used.
- b) Use of glands:

All PVC cables up to 1.1 KV grade, armoured or unarmoured shall be terminated at the



equipment / junction box / isolators / push buttons / control accessories, etc. by means of suitable size double compression type cable glands. Armour of cable shall be connected to earth point. The contractor shall drill holes for fixing glands wherever necessary. Wherever threaded cable gland is to be screwed into threaded opening of different size, suitable galvanized threaded reducing bushing shall be used of approved type.

In case of termination of cables at the bottom of the panel over a cable trench having no access from the bottom, close fit holes should be drilled in the bottom plate for all the cables in one line, and then bottom plate should be split in two parts along the centre line of holes. After installation of bottom plate and cables with glands, it shall be sealed with cold sealing compound.

USE OF LUGS / SOCKETS

All cable leads shall be terminated at the equipment terminals, by means of crimped type solderless connectors unless the terminals at the equipment ends are suitable for direct jointing without lugs / sockets.

The following is the recommended procedure for crimped joints and the same shall be followed:

- a) Strip off the insulation of the cable and with every precaution, not in severe or damage any strand. All insulation's to be removed from the stripped portion of the conductor and ends of the insulation should be clean and square.
- b) The cable should be kept clean as far as possible before assembling it with the terminal / socket. For preventing the ingress of moisture and possibility of re-oxidation after crimping of the aluminum conductors, the socket should be filled with corrosion inhibiting compound. This compound should also be applied over the stripped portion of the conductor and the palm surface of socket.
- c) Correct size and type of socket / ferrule / lug should be selected depending on size of conductor, and type of connection to be made.
- d) Make the crimped joint by suitable crimping tool.
- e) If after crimping the conductor in socket / lug, some portion of the conductor remains without insulation the same should be covered sufficiently with PVC tape.
- f) For HT cable up to 11 KV the manufacturer's recommendations should be followed.

DRESSING OF CABLE INSIDE THE EQUIPMENT

After fixing of cable glands, the individual cores of cable shall be dressed and taken along the cable ways (if provided) or shall be fixed to the panels with polyethylene straps. Cable shall be dressed in such a manner that small loop of each core is available inside the panel.

For motors of 20 HP and above, terminal box if found not suitable for proper dressing of aluminum cables, the erector shall modify the same without any additional cost.

Cables inside the equipment shall be measured and paid for.

IDENTIFICATION OF CABLES / WIRES / CORES



Power cables shall be identified with red, yellow and blue PVC tapes. For trip circuits identification, additional red ferrules shall be used only in the particular cores of control cable at the termination points in the switchgear / control panels and control switches.

In case of control cables all cores shall be identified at both ends by their wire numbers by mean of PVC ferrules or self-sticking cable markers, wire numbers shall be as per schematic / connection drawing. For power circuit also, wire numbers shall be provided if required as per the drawings of switchgear manufacturer / supplier.

TESTING OF CABLES

- Before energizing, the insulation resistance of every circuit shall be measured from phase to ground. This requires 3 measurements if one side is grounded and 6 measurements for 3 phase circuits.
- Where splices or terminations are required in circuits rated above 650 volts, measure insulation resistance of each length of cable before splicing and/or terminating. Repeat measurements after splices and/or terminations are complete.
- DC high voltage test shall be made after installation on the following :
 - a) All 1100 volts grade cables in which straight through joints have been made.
 - b) All cables above 1100 V grade.

For record purpose test data shall include the measured values of leakage current vs time.

The DC high voltage test shall be performed as detailed below :

Cables shall be installed in final position with the entire straight through joints complete.

Terminations shall be kept unfinished so that motors, switchgear, transformer etc. are not subjected to test voltage.

The test voltage and duration shall be as per relevant codes and practices of Indian Standards Institution.

PROFORMA FOR TESTING CABLES

DATE OF TEST

- a) Drum No. from which cable taken.
- b) Cable from to
- c) Length of run of this cable meter
- d) Insulation resistance test
 - i) between core-1 to earth mega-ohm
 - ii) between core-2 to earth mega-ohm
 - iii) between core-3 to earth mega-ohm
 - iv) between core-1 to core-2 mega-ohm
 - v) between core-2 to core-3 mega-ohm
 - vi) between core-3 to core-1 mega-ohm
 - vii) duration used: 1 KV
- e) High voltage test

i) between core an earth.	Voltage	Duration
ii) between individual cores		



[This Performa shall be jointly signed by the CLIENT / CONSULTANT and the contractor in duplicate].

1.35 Rigid PVC Pipes:

All non-metallic PVC conduits shall conform to IS: 9537 (Part - 3). The conduit shall be planned and of type as specified in IS: 9537 and shall be used with the corresponding accessories (Refer IS: 3419 specifications for fittings for rigid non-metallic conduits).

Installation of the system

A. Concealed Installation with Rigid PVC Conduit

- a. All the rigid PVC conduit used for concealed installation shall be as per IS : 9537 and its accessories shall be as per IS: 3419 (Small Wire Ropes).
- b. Whenever necessary bends or diversion may be achieved by bending the conduits with the help of bending spring. No other method of bending is allowed.
- c. Conduit pipes shall be joined with the help of plain coupler fixed at the end with the help of vinyl solvent cement. No other method of joining is permissible.
- d. All other methods, no wires through conduit, bunching, etc. Shall be as specified in the concealed installation.
- e. Prior to fixing the conduits, the complete route shall be marked on site for the approval of consultant.

B. Concealed Wiring System with Rigid PVC Conduit

- a. The rigid PVC conduits shall be used for concealed wiring system. The conduits shall be concealed in the concrete slab, floor, walls, beams, columns etc.
- b. **FIXING OF CONDUIT**
 - i. Conduits embedded in concrete shall be installed in the framework before pouring concrete. The conduits shall be installed above the bottom reinforcing bars and shall provide positive wire fastening of the conduit to the reinforcing rods at an interval of not more than one meter, but on either side of couplers or bends or putlet/pull/junction boxes or similar fittings, proper hold fast shall be fixed at a distance of 30 cm from the center of such fittings. Conduits embedded in the wall shall be fixed inside the chase. The chase in the wall shall be neatly made and be fixed in the manner desired. In the case of building under construction, chase shall be provided in the wall at the time of their construction and shall be filled up neatly with cement mortar 1:4 after erection of conduit and brought to the original finish of the wall. Cutting of horizontal chases in walls is prohibited. The conduits shall be fixed inside the chase by means of staples or by means of saddles not more than 60 cm apart.
 - ii. Conduits shall be so arranged as to facilitate easy drawing of wires through them. Entire conduit layout shall be done in such a way as to avoid additional junction boxes other than light points. The wiring shall be done in a looping manner. All the looping shall be done in either switch boxes or outlet boxes. Looping in junction or pull boxes are strictly not allowed. Where conduits cross building



expansion joints, adequate expansion fittings or other approved devices shall be used to take care of any relative movement.

- iii. All conduits shall be installed so as to avoid steam and hot water pipes.
- iv. Conduits shall be installed in such a way that the junction, derivation and pull boxes shall always be accessible for repairs and maintenance work. The location of junction/pull boxes shall be marked on the shop drawings and approved by the client.
- v. A separation of 200 mm shall be maintained between electrical conduits and hot water lines in the building.
- vi. No run of conduit shall exceed ten mtr. between adjacent draw in points nor shall it contain more than two right angle bends, or other derivation from the straight line
- vii. Caution shall be exercised in using the PVC conduits in location where ambient temperature is 50 degree cen. or above. Use of PVC conduits in places where ambient temperature is mote than 60 deg. cen. Is prohibited. The entire conduit system including boxes shall be thoroughly cleaned after completion of installations and before drawing of wires. Conduit system shall be erect and straight as far as possible. Traps where water may accumulate from condensation are to be avoided and if unavoidable, suitable provision for draining the water shall be made
- viii. All jointing method shall be subject to the approval of the client
- ix. Separate conduits shall be provided for the following system.
 - 15A power outlets.
 - 5A outlets and lighting system.
 - Low voltage system.
 - Telephone/intercom system.
 - C.C.T.V. system
 - Sound system
 - Computer data cabling system
 - Equipment wiring

C. Conduit Joint

- a. Conduits shall be joined by means of plain couplers vinyl and/or solvent cement. Where there are long runs of straight conduit, inspection type couplers shall be provided at intervals , as approved by the client
- b. The conduits shall be thoroughly cleaned before making the joints
- c. In case of plain coupler joints, proper jointing material like a vinyl solvent cement (gray in color) or any material as recommended by the manufacturer shall be used

D. BENDS IN CONDUIT

Wherever necessary, bends or diversions may be achieved by bending the conduits or by employing normal bends. No bends shall have radius less than 2.5 times outside dia. of the conduit



Heat may be used to soften the PVC conduit for bending, but while applying heat to conduit, the conduit shall be filled with sand to avoid any damage to the conduit.

8

E. OUTLETS

All the outlets for fittings, switches etc. shall be boxes of substantial construction. In order to minimize condensation or sweating inside the conduits, all outlets of conduit system shall be properly drained and ventilated, but in such a manner as to prevent the entry of insects, etc.

Fixing between conduit and boxes, outlet boxes, switch boxes and the like must be provided with entry spouts and smooth PVC bushes.

Joints between conduit and any type of boxes shall be affected by means of conduit couplers in to each of which shall be coupled smooth PVC bush from inside the box. In any case all the joints shall be fully water tight.

F. BUNCHING OF CABLES

Cables of AC supply of different phase shall be bunched in separate conduits

The number of insulated wires/ cables that may be drawn into the conduits shall be as per the following table. In this table, the space factor does not exceed 40%. However, in any case conduits having lesser than 19 mm dia. shall not be used.

MAXIMUM PERMISSIBLE NUMBER OF 650 VOLT GRADE SINGLE CORE CABLES THAT MAY BE DRAWN IN TO RIGID PVC CONDUITS.

CABLE SIZE IN (MM SQ.)	SIZE OF CONDUITS (MM)			
	MAXIMUM NO. OF CABLES			
	25	32	38/40	51/50
1.5	8	15	---	---
2.5	6	10	---	---
4.0	4	8	12	---



LIST OF APPROVED MAKES FOR FIRE PROTECTION WORKS

SR. NO.	DESCRIPTION	APPROVED MAKE / APPROVED VENDOR
01	Fire Extinguishers	Kanex / Minimex / Safex / New Age
02	Auto Glow Signages	Autoflow / Glowlite / Prolite / Autoglo
03	Pipe	Tata / Jindal / Surya / Alp
04	Pipe Fittings	Jainsons / Unik / Vr / Sant
05	Coating & Wrapping	Iwl / Rustek / Neotape / Pypecoat
06	Painting	Asian / Nerolac / Berger
07	RCC Pipes	Indian Hume Pipe / Pranali / Alcock
08	Pressure Switches	Switzer / Indfoss / Danfoss
09	Pressure Gauge	H. Guru / Fiebig / Hd Fire / A.N. Instruments
10	Fire Hydrants Valve	Newage / Sukan / Winco / Shah Bhogilal/ Sant / Swati
11	Rrl Hose	Newage / Shah Bhogilal / Crc/ / Sant / Swati
12	Fire Hose/ Coupling Branch Pipe/ Nozzles	Newage / Sukan / Shah Bhogilal / Crc / Sant / Swati
13	Fire Brigade Inlet	Newage / Sukan / Shah Bhogilal / Crc / Sant / Swati
14	Fire Hose Reel	Newage / Shah Bhogilal / Sri / Crc/ Sant / Swati
15	Fire Hose Cabinet	Newage / Shah Bhogilal
16	Pumps	Grundfos / Kirloskar / Ksb
17	Motor	Kec / Siemens / Cgl / Abb
18	Diesel Engine	Koel / Greaves / Groundfos / Mather Platt / Kirloskar
19	Battery	Exides / Amco / Amaron
20	Battery Charger	Servilink / Hbl / Chhabi
21	Sprinklers	H.D / Tyco / Viking / Fm Approved
22	Flow Switches	Danfoss / Forbes / Marshall / Switzer / System Sensor / Potter / Honeywell
23	Ss Corrugated Flexible Pipes Braided Type	H.D. Fire / Tyco / Viking / New Age / Rapidrop / Victaulic / Fm Approved
24	Adjustable Rosset Plate	H.D. Fire / Tyco / Viking
25	Engineered Support System	Mupro / Easy Flex / Gripe / Fischer
26	Non-Return Valve	Sant/Zoloto/Leader/Honeywell / Advance
27	Cast Iron Grating	Kapilansh / Neco
28	Pump On Off Switch	Jain Instruments / N.K. Techno Fab / Rss
29	Electric Meters	Schneider / Nippen / L & T / Socomec / Secure / Elmeasure / Ducati / Siemens / Abb
30	Starter / Switches / Mcb / Mccb / Etc.	Siemens / L&T / Schneider
31	Switchgear / Sfus	L & T / Siemens / Schneider
32	Frls Cables	Finolex / Polycab / Havells
33	Frls Wires	Finolex / Polycab / Havells
34	Butterfly Valve	Audco / L&T / Advance / Sant



SR. NO.	DESCRIPTION	APPROVED MAKE / APPROVED VENDOR
35	Sluice Valve	Audco / L&T / Advance/ Sant
36	Ball Valve	Audco / L&T / Advance / Sant
37	Strainer	Audco / Intervalve / Sant
38	Pressure Reducing Valve	Honeywell / Bernad
39	Relays	L&T / Siemens / C&S
40	Pump Panel	Cpri Approved
41	Air Release Valve	Sant / Zoloto / Shah Bhogilal/
42	Welding Electrodes	Advani / Maruti / Esab
43	Clamps / Fasteners	Hilti / Fischer / Mupro
44	Test Drain Assembly With Sight Glass	Tyco / Viking / Grinnel
45	Primer	Asian Paints / Berger / Nerolac
46	Se Expansion Bellow	Flexatherm
47	Alarm Control Valve/ Installation Control Valve	Tyco/ Hd/ Newage (Mumbai)/ Newage (Surendranagar)/ Viking/ Globe
48	Air Vessel	Nema/ Zenith/ As Per Cpwd Specifications Tested Up To 25kg/ Sqrmt
49	Anti-Vibrating Mounting Pads/ Expansion Joints	Dulop/ Resistoflex/ Easy Flex/ Flexionics/ Vimpa



SECTION IV
TECHNICAL SPECIFICATIONS
Part B: - Sanskar Kendra Plaza

FIRE FIGHTING TENDER DOCUMENT

TECHNICAL SPECIFICATION



TECHNICAL SPECIFICATION

TECHNICAL SPECIFICATION FOR FIRE FIGHTING SYSTEM WORK	3
1.1 Scope of Work:.....	3
1.2 Fire Extinguisher:.....	3
1.3 Pipe Work:.....	5
1.4 Valves.....	6
1.5 Internal Hydrant:.....	11
1.6 Hoses.....	12
1.7 Hose Cabinets (Hose Box).....	12
1.8 Hose Reel.....	12
1.9 Branch Pipes.....	12
1.10 Yard / External Hydrant.....	12
1.11 Valve Chambers.....	13
1.12 Fire Brigade Inlet Connection.....	13
1.13 System Drainage.....	13
1.14 Hydrant System.....	13
1.15 Pumps and ancillary equipment.....	14
1.16 R.C.C. PIPES.....	17
1.17 Pressure Gauge.....	26
1.18 Pressure Switches.....	26
1.19 Sprinkler Heads.....	26
1.20 Sprinkler System.....	27
1.21 Testing of the hydrant system:.....	28
1.22 Start-Up/System Testing.....	29
1.23 Technical Data Sheet.....	31
1.24 Installation of Engineered Support System.....	33
1.25 Fire Bucket:.....	44
1.26 Gunmetal orifice plates:.....	45
1.27 Air release valve:.....	45
1.28 Reflux Valve (Non-Return Valve).....	46
1.29 Air vessel:.....	50
1.30 Strainer:.....	51
1.31 Expansion Bellow:.....	51
1.32 Ball Valves:.....	52
1.33 MCC For Fire Pumps:.....	53
1.34 Cable Gland, Lugs, XLPE Armoured Cable:.....	54
1.35 Rigid PVC Pipes:.....	65

TECHNICAL SPECIFICATION

TECHNICAL SPECIFICATION FOR FIRE FIGHTING SYSTEM WORK

1.1 Scope of Work:

The scope includes fire protection system only; the detection is covered under separate tender

- a. Fire Hydrant system.
- b. Fire Sprinkler System.
- c. Fire Extinguishers.

The detailed scope is described in the chapter "Extent of Work. "

1.2 Fire Extinguisher:

General:

The scope of work under this part of the specification covers supply and installation of internal appliances as per requirements specified in schedule & marked on drawings and instructions of engineer-in-charge.

Makes of all the appliances supplied and installed shall be as per the 'List of Approved Make 'or as approved by LFA and shall be of identical design for the entire premises.

Mounting accessories, indicator boards etc are part of the scope of supply of internal appliances.

Specifications:

Internal appliances with various fire extinguishing medium shall conform to the following specifications and shall be installed and maintained as per IS: 2190 / NFPA 10

- | | |
|-----------|---|
| IS: 2878 | Fire extinguisher, portable CO2 |
| IS: 2171 | Fire extinguisher, portable, dry powder type. |
| IS: 13849 | Fire extinguishers, ABC stored pressure type. |

Portable Extinguishers of the following types shall be installed. Extinguisher to be mounted on wall.

1. ABC (Powder Type)
2. Co2 type
3. CLEAN AGENT Automatic Modular (Self Activated)

TECHNICAL SPECIFICATION

ABC (Powder Type)

6 Kg ABC (Powder Type-MAP 90%) Fire Extinguisher. In HP Mild Steel Cylinders ISI marked fitted with pressure indicating gauge, internal tube, squeeze lever type valve fully charged with ABC powder (Mono Ammonium Phosphate) pressured by Nitrogen complete in all respects including wall suspension bracket and conforming to IS:15683

CO2 TYPE:

The Co2 Extinguisher shall be ISI mark, with initial charge with high pressure cylinder, complete with wheel type valve, internal discharge tube, with high pressure discharge hose with horn and suspension brackets. The extinguisher shall have ISI mark of 2878 and capacity shall be 4.5 Kgs.

The Co2 Extinguisher of 22.5 kg. Capacity shall have ISI mark 2878 and necessary wheel valve, discharge hose and shall be mounted on light weight rubber tyre wheels.

CLEAN AGENT Automatic Modular (Self Activated):

Supplying, installation testing and commissioning of CLEAN AGENT Automatic Modular (Self Activated) fire extinguisher Automatic type, 5 kg Fire Extinguishers, Applicable fire classes A, B & C, UGTS Pressure Gauge, Empty Weight 2.64 kg, Full weight 7.64 kg, Can Height 370mm, Diameter 230 ± 10mm, made up from 2 mm thick sheet, Body Construction Deep Drawn with MIG Welding technology, Brass forged sprinkler valves with Nozzle is specially designed to give more than 95% discharge. Together with orifice characteristic to cover adequately fire risks with scattering cone of 40 to 45° Angle. Internal & External Pure polyester (UV Resistant) powder coated, Heat Sensitive Glass bulb of 68 °C. including pressure indicating gauge, ceiling mounted bracket.

Supplying, installation testing and commissioning of CLEAN AGENT Automatic Modular (Self Activated) fire extinguisher Automatic type 15 kg Fire Extinguishers Applicable fire classes A, B & C, UGTS Pressure Gauge, Empty Weight 6.40 kg, Full weight 21.40 kg. Can Height 425mm, Diameter 400 ± 10mm, made up from 2 mm thick sheet, Body Construction Deep Drawn with MIG Welding technology, Brass forged sprinkler valves with Nozzle is specially designed to give more than 99% discharge. Together with orifice characteristic to cover adequately fire risks with scattering cone of 40 to 45° Angle. Internal & External Pure polyester (UV Resistant) powder coated, Heat Sensitive Glass bulb of 68 °C. including pressure indicating gauge, ceiling mounted bracket.

Signages:

Providing & Fixing AUTOGLOW Signages in Block / Small Letters of Specified Sizes in BOQ. Signages shall be as per IS 12349-1988. The colour red, green and yellow, shall conform to Shade No. 536, 221 and 309 of IS: 5-1978. Colours for ready mixed paints and enamels (third revision) respectively. The paint shall conform to IS: 2932-1974 'Specification for enamel, synthetic, exterior (a) undercoating, (b) finishing (first revision).

TECHNICAL SPECIFICATION

1.3 Pipe Work:

General requirements:

- A All the materials shall be of ISO/LFA approved, best quality conforming to the specifications and subject to the approval of the Client or his representative. If so directed, materials shall be tested in an approved testing laboratory & the contractor shall produce the test certificate in original to the Engineer-in-charge & the entire charges for original as well as repeated tests shall be borne by the Contractor.
- B Before welding, the pipe faces shall be cleared & then shall be welded conforming to IS: 9595 – 1996. The electrodes used for welding shall comply with IS: 814. The laying of welded pipe shall also comply to IS 5822 – 2004. The welding joints shall be tested in accordance to IS: 3600, Part 1973.
- C Pipes and fittings shall be fixed truly vertical, horizontal or in slopes as required in a neat workman like manner.
- D Pipes shall be fixed in a manner as to provide easy accessibility for repair and maintenance and shall not cause obstruction in shafts, passages etc.
- E Pipes shall be securely fixed to walls and ceilings by suitable clamps or supported at every 3 mtr. & at change of direction as required. Only approved type of anchor fasteners shall be used for RCC ceiling and walls.
- F Valve and other appurtenances shall be so located that they are easily accessible for operations, repairs and maintenance.

1. PIPING

Pipes of the following types are to be used:

- A. MS/ G.I. pipes as per IS: 1239, heavy duty (for pipes of sizes 150 mm N.B. and below) suitably lagged on the outside to prevent soil corrosion. M.S. pipes buried below ground shall be lagged as per IS: 10211.
- B. MS/GI pipe lines upto 150 mm dia. shall have all fittings as per IS: 1239, Part-II (heavy grade) while pipelines above 150 mm dia shall be fabricated from IS: 3589 Gr.320 pipes as applicable or from steel plates.
- C. For MS/GI pipelines upto 50 mm dia screwed jointing shall be adopted, while for pipelines above 50 mm dia welded or flanged construction is to be carried out or as specified in Schedule of quantities.
- D. Hangers and supports shall be capable of carrying the sum of all concurrently acting loads. They shall be designed to provide the required supporting effects and allow pipeline movements as necessary. All guides, anchor, braces, dampener, expansion joint and structural steel to be attached to the building structure trenches etc. shall be provided. Hangers and components for all piping shall be approved by the Consultant / Client / Architect.

TECHNICAL SPECIFICATION

- E. The piping system shall be capable of withstanding 150% of the working pressure including water hammer effects.
- F. Flanged joints shall be used for connections to vessels, equipment, flanged valves and also on suitable straight lengths of pipeline of strategic points (@ at every 15-20 mtr.) to facilitate erection and subsequent maintenance work.
- G. Excavation for pipe line shall be in open trenches. Pipes shall be buried at least one meter below ground level and shall have 230 mm x 230 mm masonry supports at least 300mm high at 3m intervals. Masonry work to have plain cement concrete foundation (1 cement: 4 coarse sand: 8 stone aggregate) of size 380 x 380 x 75 thick resting on firm soil.
- H. Wherever required Contractor shall support all trenches or adjoining structures with adequate supports to prevent landslides.
- I. On completion of testing and painting trenches shall be refilled with excavated earth in 15 cm layers and compacted.
- J. Contractor shall dispose off all surplus earth within the site.
- K. Contractor shall provide suitable cement concrete anchor blocks for overcoming pressure thrusts in underground / external pipes. Anchor blocks shall be of cement concrete 1:2:4 mix.

1.4 Butterfly Valves

Butterfly valves as per IS - 13095/ 1991

- SCOPE - Fabricated valve will not be considered.
- This standard cover is double flanged and wafer type of metal seated, resilient seated cast iron, ductile iron, and carbon steel and lined butterfly valves for general purpose. Valves covered under this standard are manually, pneumatically, hydraulically or electrically operated.
- It covers valves of nominal pressure designations up to and including 4 MPa. and class 300 with ends flanged in accordance with appropriate table of IS 6418: 1971 'Cast iron and malleable cast iron flanges for general engineering purpose' or wafer type valves with bodies designed to be accommodate between pipe work flanges in accordance with appropriate table of IS 6418: 1971 or IS 6392: 1971 'steel pipe flanges' in nominal size DN 40 to DN 2000. It also covers valves up to class 300 and flanges as per the pressure/temperature ratings given in IS 13159 (Part 1): 1991 'steel pipe flanges and flanged fittings: part I dimensions and IS 6418: 1971 'cast iron and malleable cast iron flanges for general engineering purposes.
- REFERENCE
 - The applicable Indian standards are necessary adjuncts to this standard.
- TERMINOLOGY AND DEFINITIONS
 - Terminology and definition covered in IS 4854 (Part3) : 1974 are generally applicable.
- VALVE END CONNECTIONS

TECHNICAL SPECIFICATION

- Double flanged valves
- A valve having flanged ends for connection to pipe flanges by individual bolting.
 - Water valve
- A valve for clamping between two pipe flanges using through bolting this may be single flange, lug type, U- section or flangeless type.
- SERVICE APPLICATIONS
 - Valves shall be suitable for one or more of the following applications.
 - Tight shut off - A valve having no visible leakage past the disc in closed position under test conditions.
 - Regulating - A valve intended for regulating purpose and which may have a clearance between the disc and the body in close position.
 - Low leakage - A valve which has specified maximum leakage rate past the disc in the closed position.
- VACUUM CONDITION
 - Where valve are to be used under vacuum conditions, purchaser shall mention specifically, and the detailed design provision shall be mutually agreed between the purchaser and the manufacturer.
- NOMINAL SIZES
 - The range of nominal valve size (DN) in mm shall be as follows:
 - 40,50,65,80,100,150,200,250,300,350,400,450,500,600,700,800,900,1000,1200,1400,1600,1800 and 2000
- NOMINAL PRESSURES
 - Valve shall be designated by nominal pressure (PN) defined as the maximum permissible working pressure (Mpa) at 20 0 C temperatures as follows:
 - PN 0.25, PN 0.6, PN 1.0, PN 1.25, PN 1.6, PN 2.0, PN 2.5 and PN 4.0.
 - The class designation for valves specified by nominal pipe size shall be class 125, class 150 and class 300.
- PRESSURE/TEMPERATURE RATINGS
 - Maximum permissible gauge working pressure and operating temperatures shall be in accordance with IS 6418 : 1971 and IS 13159 (Part I) : 1991 except that restriction on temperature may be placed by the manufacturer on valves in accordance with this standard by reason of valve type, trim materials or other factors. However, all valves shall be suitable for continuous use at their PN designation within the temperature range of -10° c to 65° c.
- BODY ENDS
 - Double Flanged Body Ends
- The dimensions of flanged body ends and drillings shall be in accordance with the requirement given in Annex B. Flanges as per any other specific requirements of the purchaser may also be given as agreed to between the manufacturer and the purchaser or as per I.S. 13159 (part I) : 1991.
- Flanges shall be at right angles to the axis of the bore and concentric with the bore.

TECHNICAL SPECIFICATION

- Flanges shall be drilled unless otherwise specified and bolt holes shall be off centers. Tapped by the design of the valve.
- Wafer Body Ends
- Body ends shall be capable of being fitted between the pipe flanges complying with the requirements of annex B flange drilling.
- The joint faces shall be at right angles to the axis of the bore and concentric with the bore.
 - Holes may be provided, where required by the design, for the passage of the bolts securing the flanges and the valve. Where through bolting is not practicable due to the presence of valve shaft, bearing housing, tapped holes may be provided for individual bolting of each flange.
- FACE TO FACE DIMENSIONS
 - Face to face dimensions of double flanged and wafer types of valve shall be as per Table 1.
 - Face to face dimensions given in Table 1 are exclusive of the sealing gaskets at both ends.
 - The manufacturer shall ensure that adequate space will be available between valve flanges for bolting when flanged valve with short body face to face or wafer long face to face are manufactured.
 - Tolerance on face to face dimensions in Table 1 shall be as follow.

Face to face dimension of Unlined valve MM		Tolerance MM
Over	Up to and including	
0	250	+2
250	500	+3
500	800	+4
800	1000	+5
1000	2400	+6

- BODIES
 - Bodies end ports shall be circular and the numerical valves of the diameter shall be as close as possible to the valve of DN.
- DISC AND SHAFT
 - The disc and shaft shall be designed to withstand the maximum pressure differential across the valve in either direction of flow. The shaft may be of one piece design or in two pieces separately attached to the disc. Any means of attachment between the shaft and the disc shall be such as to preclude components becoming loose in service.
- SEATING AND LININGS
 - Non-integral seating, and lining where used, and their means of attachment shall be such as to preclude their becoming loose in service.
- BEARINGS
 - The bearings shall be suitable for the maximum loads imposed by the shaft during testing and in service.
 - For valves DN 350 and above, a bearing shall be provided to take the axial thrust; spring retaining clips (cir clips) shall not be used as thrust bearing.

TECHNICAL SPECIFICATION

- Suitable sealing shall be provided for the shaft where it passes outside the pressure containing en closer.
- MATERIALS
 - This standard is based on materials specified in Table 2. Unless otherwise agreed, the materials shall be of a grade equivalent to those given in Table 2 or superior. Other material may be used as per agreement between the manufacturer and the purchaser.
- OPERATION
 - Manually Operated
 - All valves shall be capable of operated at a differential pressure across the disc as marked on the valve. Lever, worms gear/traveling nut type or any other suitable type of operator can be used.
 - Direction
 - Unless otherwise, specified manually operated valves shall be closed by turning hand wheel or lever in a clockwise direction when facing the hand wheel or lever. The design of lever when fitted shall be such that the lever may only be assembled to the valve so that it is parallel to the direction of flow when the valve is open.
 - All gear traveling nut operators shall be provided with suitable stops to prevent movement of the shaft beyond the limit corresponding to the fully closed position of the disc.
 - All gear traveling nut operators shall be packed with grease for life time operation. Gear/traveling nut operators shall be totally enclosed and weather proof for general application. For special applications such as marine, submerged service etc. The purchaser may specify special en-closer.
 - All gear/traveling nut operators shall be self locking type. All lever operated valve shall be capable of being locked at least three intermediate position.
 - The operating hand-wheels shall be marked 'CLOSE' or 'SHUT' to indicate the direction of closer.
 - The operator shall be provided with arrangement to indicate the disc position.
- TESTING
 - All valves shall hydrostatically tested by the manufacturer before dispatch. The pressure shall be obtained without any significant hydraulic shock. Testing shall be carried on before application of paint or other similar treatment unless otherwise agreed between the purchaser and the manufacturer. There shall be no air entrapped within the part of the valves subjected to test pressure.
 -
- PERFORMANCE TESTING
 - Each valve shall be shop operated from fully closed to fully open position and reverse, under no pressure and no flow condition to demonstrate that the complete assembly is workable.
- BODY TEST
 - Completely assembled valve shall be tested as follows:
 - The body ends shall be blanked so that the valve is subjected to the full pressure in all directions include by the test pressure wafer valves may be tested in any suitable manner agreed between the purchaser and the manufacturer. The valve disc shall be in slightly open position and pressure equivalent to 1.5 times the maximum permissible

TECHNICAL SPECIFICATION

working pressure shall be applied with water. The duration of this test shall be as in Table 3.'

- SEAT TEST

- o The seating surface of the valve shall be cleaned unless a surface treatment forms an integral part of the design or the use of a temporary surface treatment has been agreed between the manufacturer and the purchaser to avoid the possibility of damage under the condition of the test.

TABLE-3

NOMINAL DIA MM	MINIMUM TEST DURATION IN MINUTES	
	BODY TEST	SEAT TEST WHEN APPLICABLE
Up to and including 50	0.25	0.25
65 to 150	1.0	1.0
200 to 300	2.0	2.0
350 to 1000	5.0	2.0
1200 to 2000	5.0	3.0

- o Each valve shall be shop tested for leaks in close position. The test shall be conducted with the body flanges in a horizontal position. Pressure shall be applied to the upstream end of the valve, the downstream being open to atmosphere. The duration of test shall be as per Table 3. There shall be no indication of leakage past the valve disc during test and valves shall be drop tight. Seat test shall be carried out in both the direction of valve if agreed between the manufacturer and the purchaser. The seat pressure applied on upstream side shall be equivalent to 1.1 times the maximum permissible working pressure at 20° c and shall be applied with water.
- o For regulating type valves seat test shall not be applicable.

- DISC STRENGTH TEST

- o The test shall be conducted with the body flanges in horizontal position. The test pressure shall be 1.5 times the maximum permissible pressure at 20.0 C With disc in closed position, hydro test pressure shall be applied to the lower face of the disc for duration as per table-3. There shall be no damage to the valve disc nor shall any part of valve or disc be permanently deformed by the test. The purpose of this test is to provide evidence of the adequacy and structural integrity of disc and body. Any leakage past the seat shall not be the criteria for rejection of the valve (Sampling test sample as per IS 2500). For regulating type valves, disc strength shall not be applicable.
- o Maximum permissible leakage shall be as per table 4.

- TEST CERTIFICATES

- o When specified by the purchaser, the manufacturer shall issue a test certificate conforming that the valves have been tested in accordance with this standard and stating the actual pressures and medium used in the test.

TABLE 4	
VALVE TYPE	LEAKAGE RATE
Tight shut-off	No visible leakage for duration of test
Low leakage	0.1 mm ² /s X DN (sec 5)
Regulating	Not specified. Outside the scope of this

TECHNICAL SPECIFICATION

standard.

- INSPECTION
 - If inspection is required, this shall be stated in the enquiry/order. The purchaser or his authorized representative shall have access to the manufacturer's works at all reasonable times to inspect assembled valve to his order.
- WITNESSING OF TESTS
 - When the purchaser desires to witness the tests, this shall be specifically agreed in advance.
- MARKING
 - Marking shall be cast integral on the body or on a plate securely attached to the body. The markings shall be in accordance with I.S. 9866: 1981.
- PREPARTION FOR DESPATCH
 - Valve shall be complete in all respect when shipped. Each valve shall be drained, cleaned, prepared and suitable protected with 2 coats of red oxide on un machined surfaces and rust preventive coats on machined and flanged surfaces for dispatch in such a way as to minimize the possibility of damage and deterioration during transit and storage. Painting other than specified on the finished valve shall be as per the agreement between the manufacturer and the purchaser.
 - Disc shall be unseated when dispatched, but care shall be taken to ensure that there is no risk of damage to the disc.
 - When specified, the body ends shall be suitably sealed to exclude foreign matter during transit and storage.
 - Components shipped unattached shall be adequately protected and identified to permit correct field assembly.

1.5 Internal Hydrant:

Internal hydrant shall be provided at each landing or at suitable location consisting of single / twin headed gunmetal landing valve as indicated in BOQ with 63 mm dia oblique female instantaneous pattern with caps & chains. Outlet and 80 mm inlet (IS: 5290-1993) with separate shut off valve. Landing valves shall be 63 mm dia. oblique female instantaneous pattern with caps and chains. Landing valves shall be of gunmetal and fitted with instantaneous coupling conforming to IS: 901. The valve body, stop valve, checks valve, nut, instantaneous female outlet and blank cap shall be of leaded-tin bronze conforming to Grade-II of IS: 318-1962. The valve spindle shall be of brass rod conforming IS: 320 - 1962. The hand wheel shall be mild steel or cast-iron washers gaskets shall be of rubber conforming to IS:638 - 1965 or leather conforming to IS:581: 1969. The coupling shall be fitted with an internal plug secured by chain landing valves shall be installed on hydrant riser at a height of 1.0 to 1.2 meter from the floor level.

Each internal hydrant shall be provided with two nos. 63 mm. Diameter 15 mtr. Long hose pipe with gunmetal male and female instantaneous type coupling, machined

TECHNICAL SPECIFICATION

wound with G.I. wire hose of IS 636 type A and couplings to IS:903 with IS certification, gunmetal branch pipe with nozzle conforming to IS:903.

1.6 Hoses

Hoses pipes shall be of fabric reinforced rubber lines as per IS:636 Type II or canvas hose as per IS:4927, with nominal size of 63 mm and lengths of 15 meter or 7.5 meter, as per quantities specified for in schedule or bill of quantity.

All hose pipes shall carry ISI marking on the body of the hose.

The hose shall have instantaneous spring lock-type coupling on ends. The instantaneous coupling shall be as per IS: 901. It shall be fixed to each other by copper rivets and galvanized M.S. wires and leather bands. All coupling shall be interchangeable with each other and shall bear ISI markings.

1.7 Hose Cabinets (Hose Box)

Each hydrant shall be housed in a Hose cabinet of suitable size. The hydrant cabinet shall hold double / single headed hydrant as specified, 2 hoses and one branch pipe as required. Internal hydrants shall normally fit the size of the niche made for it. The cabinet shall be of minimum 16 SWG M.S. sheet with center opening, double glass front doors (clear glass of 4mm thickness). The glass shall be firmly fixed by means of steel clips and screw with rubber beading. Hinges shall also be screwed and not welded. The corner members (frame) shall be of 25 x 25 x 3 mm thick angle. The hose box shall be firmly fixed to the wall/support by means of brackets and dash fasteners. The steel work shall have one coat of primer and two coats of red paint. The words "Yard Hydrant", "Hydrant" etc. should be painted in white or red on the glass in 75 mm high letters. The hose box shall be lockable for internal hydrant installation.

1.8 Hose Reel

The hose reel shall be directly tapped from the riser through a 25 / 32 mm dia pipe, the drum and the reel being firmly held against the wall by use of dash fasteners. The hose reel shall be swinging type (180degrees) and the entire drum, reel etc. shall be as per IS: 3876 and IS: 884. The rubber tubing shall be of best quality and the nozzle shall be shut off type.

1.9 Branch Pipes

Branch pipe shall be of either gun metal or aluminum and should conform to IS: 903. One end of the branch pipe will receive the coupling while the other end shall have a nozzle screwed to it. It shall bear ISI marking.

1.10 Yard / External Hydrant

Yard or External Hydrants shall be as per IS: 908 and the valve as per IS: 5290. The hydrant shall consist of stand post assembly and a masonry base 200 mm X 200 mm X 200 cm high and shall be made at the point where it comes out of the soil. The valve shall complete with hand wheel, quick coupling connection spring and blank cap. The hydrant shall be laid on 150 dia. or as mentioned in BOQ.

TECHNICAL SPECIFICATION

Yard or External hydrant shall have oblique female instantaneous pattern 63 mm diameter outlets with caps and chains. The hydrant shall be of gunmetal and flange inlet and single outlet conforming to IS: 5290, a duck foot bends and flanged riser of required height to bring the hydrant to level above ground. The valve body, stop valve, checks valve, nut, instantaneous female outlet and blank cap shall be of leaded-tin bronze conforming to Grade-II of IS: 318-1962. The valve spindle shall be of brass rod conforming IS: 320 - 1962. The hand wheel shall be mild steel or cast iron washers gaskets shall be of rubber conforming to IS:638 - 2003 or leather conforming to IS:581 : 1969.

Each external hydrant shall be provided with two nos. 63 mm. Diameter 15 mtr. Long hose pipe with gunmetal male and female instantaneous type coupling, machined wound with G.I. wire hose of IS 636 type A and couplings to IS:903 with IS certification, gunmetal branch pipe with 20 mm nozzle conforming to IS:903.

1.11 Valve Chambers

A valve chamber shall be brick masonry chamber in cement mortar 1:5 (1 cement: 5 coarse sand) on cement concrete foundation 150 mm thick foundation 1:5:10 mix (1 cement: 5 fine sand: 10 graded stone aggregate 40 mm nominal size), 15 mm thick cement plaster inside and outside finished with a floating coat of neat cement inside with cast iron surface box approved by fire brigade including excavation, back filling, complete. The wall shall be 230 mm thick with heavy duty ISI marked C.I. manhole covers.

1.12 Fire Brigade Inlet Connection

A fire brigade inlet connection with a non-return valve shall be provided to facilitate the fire brigade to pump water into the installation by the use of their own equipment. Four way or 150 mm dia connection to the system shall comprise of four instantaneous pattern 63 mm dia. male inlets shall be with caps and chains complete with 150 mm dia. sluice valves, non-return valve housed in a M.S. cabinet with glass fronted door. The cabinet shall be suitable for recess mounting.

Two way or 100 mm fire brigade inlet connection to the system shall comprise of two instantaneous pattern 63 mm dia. male inlets shall be with caps and chains complete with 100 mm dia sluice valve, non-return valve housed in a M.S. cabinet with glass fronted door. The cabinet shall be suitable for recess mounting.

1.13 System Drainage

The systems shall be provided with suitable drainage arrangements with G.I. /MS piping of 50 mm dia. complete with all accessories and provided with drain valve.

1.14 Hydrant System

The hydrant system shall comprise of AC motor driven pump sets. Diesel pump, Jockey pump etc. with all required accessories including valves, appurtenances, instrumentation and controls etc. complete in all respects. The system shall cover the entire area from independent pipe work from the fire water pump set. The hydrant work shall remain pressurized through the proposed Jockey pump taking care of any leakages in the system pipelines and valve glands. All pumps / motors / engines to be of makes approved by local Fire Authority.

TECHNICAL SPECIFICATION

The hydrant system shall be kept charged by pressurized water at approximately 7.5 Kg/cm² at all times. In the event of fire when any of the hydrant valves in the network is opened, the resultant fall in header pressure should enable starting the Electric Motor driven fire water pumping set through pressure switches automatically. One Diesel Engine / DG set driven pump shall be a stand-by pump serving hydrant system & sprinkler both. In case of failure of electricity or failure of Elec. Pump to start on demand, the stand-by DG set operated pump shall automatically take over. Apart from the automatic starting of the pump sets, provision shall be kept for manual starting also. However, shifting down of the pump sets shall be manual.

The hydrant system in the yard shall be furnished with external hydrants consisting of landing valves (positioned approx. one meter above ground level) fitted M.S. (Heavy) flanged single headed standpipes installed on underground hydrant headers distributed 45 M apart approximately or as marked on the plan.

The entire system including all pumps, motors, diesel pump set and panels shall be of approved make by ISO / Local Fire Authority.

1.15 Pumps and ancillary equipment

Scope of Work

- A. Work under this section shall consist of furnishing all labour, materials, equipment and appliances necessary and required to completely install electrically operated pumps for fire hydrant installations as required by the drawings and specified hereinafter or given in the schedule of quantities.
- B. Without restricting to generality of the foregoing the pumps and the ancillary equipment and shall include the following:
 - a. Electrically operated pumps with motors base plate and accessories.
 - b. Pump suction and delivery headers, valves, air vessel and connections.
 - c. Pressure gauges / pressure switch.
 - d. Only single point 3 phase supply will be made available to the Contractor. From there, all provision viz. Electrical switchboard, wiring, cabling, cable tray, control panel, earthing, etc. shall be made.

General Requirement

- a) Pumps shall be installed true to level on suitable concrete foundations. Base plate shall be firmly fixed by foundation bolts properly grouted in concrete foundations.
- b) Pumps and motors shall be truly aligned with suitable instruments.
- c) All pump connections shall be standard flanged type with appropriate number of bolts.

TECHNICAL SPECIFICATION

- d) Manufacturer instructions regarding installation connections and commissioning shall be followed with respect to all pumps, switchgear and accessories.

Fire and Jockey Pumps

- a) The main Fire hydrant & Sprinkler pumps shall be End Suction Back Pull Out / Split Casing type while Jockey pumps shall be of Centrifugal Mono block Pump type having following specifications.
- b) Shut off head should not exceed 140% of rated head. Pump shall not develop less than 65% of rated head at 150% of rated capacity

MATERIALS OF CONSTRUCTION

Part	Material
Casing	Cast Iron
Impeller	Bronze IS: 318, Gr. LTB 2
Casing Wearing	SS
Shaft	AISI – 410 / Stainless Steel
Shaft Sleeve	S.S. 316
Stuffing Box	Gland Packed

- c) Pumps shall be provided with pressure gauge with isolation cock on the delivery side.
- d) In case of motor driven pump the motor rating should be adequate to drive the motor rating should be adequate to drive the pump at 150% of rated discharge.
- e) The pump and its prime mover (Electric motor or Diesel Engine) shall comply with all the equipment of the Rules of the Traffic Advisory Committee.
- f) All pumps shall have positive suction & shall be provided with suction strainer of SS & CI bell mouth. In case of negative suction suitable priming arrangement shall be provided.
- g) In first phase only, all pumps shall be installed. Pump head shall be considering ultimate phase.

Jockey Pump

Starting and stopping of Jockey Pump set shall be automatic at predetermined levels through pressure switch. However, arrangements for manual start and stop of the pump shall also be made. Jockey Pump shall take care of small leakages in the piping system and pumps cushion tanks.

Electric Driven

Electrically driven pumps shall be provided with totally enclosed fan cooled, foot mounted, squirrel cage induction motors suitable for fire pumps with IP-55 enclosure.

The motors should be rated not to draw more than 4.5 times the starting current.

TECHNICAL SPECIFICATION

Motors shall be at least equivalent to the horse power required to drive the pump at 150% of its rates discharge.

The motors shall be wound for class-F insulation and windings shall be vacuum impregnated with heat and moisture resisting varnish, glass fiber insulated.

Diesel Engine

- a) Diesel engine shall have suitable no. of cylinders with individual heat assemblies. The engine shall be water cooled and shall include heat exchanger and connecting piping strainer, isolating pressure reducing valves, bye-pass line, exhaust pipe, silencer, day tank for fuel all interconnected piping etc., complete in all respects.
- b) Engine shall be direct injection type with low noise and exhaust omission levels,
- c) The speed of engine shall match the pump speed for direct drive.
- d) The engine shall be capable of being started without the use of the wicks, cartridge heater plugs or either at engine room temperature of 4°C and shall take full load within 15 seconds from the receipt of the signal to start.
- e) The engine shall effectively operate at 46°C ambient temperature at 150 meter above mean sea level.
- f) Engine shall be suitable for running on high speed diesel oil.
- g) The system shall be provided with a control panel with push button starting arrangement also wired to operate the engine on differential pressure gauge.
- h) The entire system shall be mounted on a common structural base plate with anti-vibration mounting, Dunlop make, and flexible connections on the suction and delivery piping.
- i) Contractor provide one fully mounted and supported Day Oil Tank fabricated from 6mm thick MS sheet electrically welded for 8 hours working load and having suitable capacity of oil. Provide level indicators – low level and full level in the Day Oil Tank on the control panel through float switches and a breather. Day Oil Tank shall also be provided with filling connection (Threaded) with cap, gauge glass indication and cocks, drain cock, inspection / cleaning cover with gasket and nuts / bolts. MS dyke to hold 150% of the Day Tank capacity to be built around the Day Tank.
- j) Contractor to provide one exhaust pipe with suitable muffler (residential type) to discharge the engine gasses to outside in open air as per site conditions (Contractor to check the site).
- k) Contractor to provide all accessories, fittings and fixtures necessary and required for a complete operating engine set. The exhaust pipe shall be taken outside the building with minimum number of bends (approx. length 30 Meters) and shall be duly heat insulated with 50mm thick glass wool covered with 24-gauge aluminum cladding.

TECHNICAL SPECIFICATION

- l) Contractor shall indicate special requirements, if any, for the ventilation of the Pump Room.
Noise & Vibration level of the pump driven by motor/engine shall be within the acceptable limits of ISO 2372, IS 11727.

BOOSTER PUMP:

A booster pump shall be provided at terrace to pressurize the wet riser system. The pump shall be centrifugal end suction / mono block type.

BASE PLATE

Pumps and motors shall be mounted on a common structural base plate and installed as per the manufacturer's instructions.

1.16 R.C.C. PIPES

SCOPE :

This specification covers the requirements for manufacture, supplying, lowering, laying, jointing, testing and commissioning of reinforced cement concrete (RCC) pipes used for the conveyance of sewage & storm water .

CODES & STANDARDS :

The manufacturing, testing, supplying, jointing and testing at work sites of RCC pipes shall comply with all currently applicable statutes, regulations, standards and codes. In particular, the following standards, unless otherwise specified herein, shall be referred.

MATERIALS

1. IS : 458 Specification for pre cast concrete pipes (with and without reinforcement)
2. IS : 3597 Method of tests for concrete pipes.
3. IS : 432 Specification for mild steel and medium (tensile steel bars and hand drawn steel) wires for concrete reinforcement.
4. IS : 5382 Specification for rubber sealing rings for gas mains, water mains & sewers
5. IS : 516 Method of test for strength of concrete.

CODE OF PRACTICE

IS : 456 Code of practice for plain and reinforced concrete

DESIGN

Design of RCC pipes including reinforcement details and the ends of pipes shall be in accordance with the relevant clauses of IS : 458.

GENERAL

TECHNICAL SPECIFICATION

The method of manufacture of RCC pipes (Class NP 3) shall be such that the form and the dimensions of the finished pipes are accurate within the limits specified in relevant clause of IS : 458. The surfaces and edges of the pipes shall be well defined and true, and their ends shall be square with the longitudinal axis. The ends of the pipes shall be further reinforced by an extra ring of reinforcement to avoid breakage during transportation.

The RCC pipes and rubber rings shall be systematically checked for any manufacturing defects by experienced supervisors so as to maintain a high standard of quality.

The engineer shall at all reasonable times have free access to the place where the pipes and collars/rubber rings are manufactured for the purpose of examining and testing the pipes and collars/ rubber rings and of witnessing the test and manufacturing.

All tests specified either in this engineer's requirements or in the relevant Indian standards shall be performed by the supplier/contractor at his own cost and in presence of the engineer if he so desires. For this, sufficient notice before testing of the pipes and fittings shall be given to the engineer.

If the test is found unsatisfactory, the engineer may reject any or all pipes of that lot.

MATERIALS

1. CEMENT

Sulfate resisting cement shall be used for the manufacture of RCC pipes and fittings and shall conform to IS 12330.

2. AGGREGATES

Aggregates used for the manufacture of RCC pipes shall conform to 3 of IS : 383. The maximum size of aggregate should not exceed one third the thickness of the pipe or 20mm, whichever is smaller for pipe size above 250 mm. For 80 to 250 mm size, the maximum size of the aggregate shall be 10 mm.

3. MIXING AND CURING WATER

Water shall be clean, colourless & free from objectionable quantities of organic matter, alkali, acid, salts, or other impurities that might reduce the strength, durability or other desirable qualities of concrete and mortar.

4. REINFORCEMENT

Reinforcement used for the manufacture of the reinforced concrete pipe shall conform to mild steel Grade 1 or medium tensile steel bars conforming to IS : 432 (part-1) or hard-drawn steel wire conforming to IS : 432 (part-2) or structural steel (standard quality) bars conforming to IS 2062. Reinforcement cages for pipes and collars shall be as per relevant requirement of IS : 458.

5. CONCRETE

Concrete used for the manufacture of RCC pipes shall conform to IS : 456. The minimum cement content and minimum compressive strength of concrete shall be as per relevant requirements of IS : 456. Compressive strength tests shall be conducted on 15 cm cubes in accordance with the relevant requirements of IS : 456 and IS : 516.

CURING

TECHNICAL SPECIFICATION

Pipes manufactured in compliance with IS : 456 shall be water cured in accordance with the relevant requirements of IS : 456.

DIMENSIONS & TOLERANCE

- a. The internal diameter, wall thickness and length of barrel, reinforcement (longitudinal and spiral), type of ends and minimum clear cover to reinforcement and strength test requirements shall be as per the relevant clauses / tables of IS : 458 for class NP3 RCC pipes.
- b. The tolerances regarding overall length, internal diameter of pipes or sockets and barrel wall thickness shall be as per relevant clause of IS : 458.

WORKMANSHIP & FINISH

- a. Pipes shall be straight and free from cracks except that craze cracks may be permitted. the ends of the pipes shall be square with their longitudinal axis.
- b. The outside and inside surfaces of the pipes shall be smooth, dense and hard, and shall not be coated with cement wash or other preparation unless otherwise agreed to between the engineer and the manufacturer or supplier
- c. The pipes shall be free from defects resulting from imperfect grading of the aggregate, mixing or moulding.
- d. The pipes shall be free from local dents or bulges greater than 3 mm in depth and extending over a length in any direction greater than twice the thickness of barrel.
- e. The deviation from straight in any pipe throughout its effective length, tested by means of rigid straight edge parallel to the longitudinal axis of the pipe shall not exceed, for all diameters 3 mm for every meter run.

TESTING

- a. All pipes for testing purposes shall be selected at random from the stock of the manufacturer and shall be such as would not otherwise be rejected under the criteria of tolerances as mentioned in IS : 458.
- b. During manufacture, compressive strength of concrete cubes shall be done as described in IS 516. For pressure pipes, splitting tensile strength tests of the concrete cylinders shall be carried out as described in IS 5816. The manufacturer shall supply, when required to do so by the engineer, the results of compressive tests of concrete cubes and split tensile tests of concrete cylinders made from the concrete used for the pipes. the manufacturer shall supply cylinders or cubes for test purposes required by the engineer and such cylinders or cubes shall withstand the tests prescribed as per IS : 458. Every pressure pipe shall be tested by the manufacturer for the hydrostatic test pressure, for non-pressure pipes, 2 percent of the pipes shall be tested for hydrostatic test pressure in accordance with IS 458.

TECHNICAL SPECIFICATION

c. The specimen of pipes for the following tests shall be selected in accordance with relevant clause of IS : 458 and tests in accordance with the methods described in IS : 3597.

- **Hydrostatic Test**
- **Three-edge bearing Test**
- **Permeability Test**

SAMPLING & INSPECTION

In any consignment, all the pipes of same class and size and manufactured under similar conditions of production shall be grouped together to constitute a lot. the conformity of a lot to the requirements of this specification shall be ascertained on the basis of tests on pipes selected from it.

The number of pipes to be selected from the lot for testing shall be in accordance with table 22 of IS : 458.

Pipes shall be selected at random. In order to ensure randomness of selection, all the pipes in the lot may be arranged in a serial order and starting from any pipe, every pipe shall be selected till the requisite number is obtained and or procedures given in IS 4905 may be followed.

All pipes selected shall be inspected for dimensional requirements, finish and straightness. A pipe failing to satisfy one or more of these requirements shall be considered as defective.

The number of pipes to be tested for tests under clause 10.2 shall be in accordance with column 4 of table 22 of IS : 458. These pipes shall be selected from pipes that have satisfied the requirements of dimensions, finish and deviation from straight.

A lot shall be considered as conforming to the requirements of IS : 458 if the following conditions are satisfied.

The number of defective pipes (those not satisfying one or more of the requirements for dimensions, finish and deviation from straight shall not be more than the permissible number given in clause 8 & 9 of IS : 458.

All the pipes tested for various tests as per Clause shall satisfy corresponding requirements of the tests.

In case the number of pipes not satisfying requirements of any one or more tests, one or two further samples of the same size shall be selected and subjected to the test or tests in which the failure has occurred. All these pipes shall satisfy the corresponding requirements of the test. In the event they do not, the lot will be rejected.

MARKING

The following information shall be clearly marked on each pipe :

- a. Internal diameter of pipe
- b. Class of pipe
- c. Date of manufacture an
- d. Name of manufacturer or his registered trademark or both.

TECHNICAL SPECIFICATION

CARTING & HANDLING

Unless waived by the engineer, method statements shall be submitted by the contractor for the approval of the engineer before the handling, transportation and laying of any pipes commences. All pipes shall be handled and stored in compliance with the manufacturer's recommendations. Pipes and fittings /specials shall be transported from the factory to the central pipe store and unloaded there before being transported to site. At every point of loading or unloading, all pipes and fittings shall be lifted using approved lifting tackle. Unloading by rolling down any form of inclined ramp will not be permitted. Pliable straps or slings shall be used to lift pipes. Rope, wire rope, hooks or chains shall not be allowed to come into contact with any pipe surface. All pipes shall be thoroughly inspected on arrival on site and immediately prior to installation. Any damage to the pipes shall be notified to the engineer for a decision as to the acceptability of the pipes, with or without repairs or remedial work. The final judgement will be taken by the engineer based on his judgement of the suitability of the items for the purpose intended.

STORAGE

Each stack of pipes shall contain only pipes of same class and size, with consignment or batch number marked on it with particulars of suppliers wherever possible. storage shall be done on firm level and clean ground and wedges shall be provided at the bottom layer to keep the stack stable. the stack shall be in pyramid shape or the pipes laid lengthways and crosswise in alternate layers. the pyramid stack shall be made for smaller diameter pipes for conserving space in storing them. the height of the stock shall not exceed 1.5 m.

Rubber rings shall be stored in a clean, cool store away from windows, boiler, electrical equipment and petrol, oils or other chemicals.

PIPELINE CONSTRUCTION (GENERAL)

Pipes shall be laid and jointed in accordance with all relevant recommendations of the manufacturer. Any variations between the manufacturer's recommendations and this specification shall be highlighted in the contractor's method statements and a ruling will be given with the approval. All pipelaying shall be performed by experienced and competent pipelayers.

The line of the pipe shall be set out and agreed with the engineer well in advance of the excavation. Surface stripping, excavation, pipelaying, backfilling and reinstatement shall follow each other without undue delay or interval between these activities.

LAYING OF PIPES

In laying the pipes and fittings/ specials the center for each manhole / chamber or pipeline shall be marked by a peg. Contractor shall dig holes for and set up two posts (about 100 x 100 x 1800 mm) at each manhole / chamber or junction of pipelines at nearly equal distance from the peg and at sufficient distances there from to be well clear of all intended excavation, so arranged that a sight rail when fixed at a certain level against the post shall cross the center line of the manhole/chamber or pipe lines. the sight rail shall not in any case be more than 30 m apart, intermediate rails shall be put up if directed by engineer.

Boning staves of 75 mm x 50 mm size shall be prepared by contractor in various lengths, each length being of a certain whole number of meters and with a fixed tee head and fixed intermediate cross pieces, each about 300 mm long. The top-edge of the cross piece must be fixed below the top-edge of the tee-head at a distance equal to the outside diameter of

TECHNICAL SPECIFICATION

the pipe or the thickness of the concrete bed to be laid as the case may be, the top of cross pieces shall indicate different levels such as excavation for pipe line, top of concrete bed, top of the pipe etc. as the case may be.

The sight rail of size 250 mm x 40 mm shall be screwed with the top edge resting against the level marks. The centre line of the pipe shall be marked on the rail and this mark shall denote also the meeting point of the centre lines of any converging pipes. A line drawn from the top edge of one rail to the top edge of the next rail shall be vertically parallel with the bed of the pipe, and the depth of the bed of pipe at any intermediate point may be determined by letting down the selected boning staff until the tee head comes in the line of sight from rail to rail.

The post and rails shall be perfectly square and planed smooth on all sides and edges. The rails shall be painted white on both sides, and the tee-heads and cross-piece of the boning staves shall be painted black.

For the pipes converging to a manhole/chamber at various levels, there shall be a rail fixed for every different level. When a rail comes within 0.60 m of the surface of the ground, a higher sight-rail shall be fixed for use with the rail over the next point. The posts and rails shall in no case be removed until the trench is excavated, the pipes are laid and engineer gives permission to proceed with the backfilling.

LAYING OF PIPES & FITTINGS/SPECIALS

The joints and interiors of all pipes and fittings shall be carefully cleaned before installation. Whenever pipelaying is interrupted for any reason, the open end of the pipeline shall be sealed with a suitable expanding stopper or a properly fitted temporary wooden stopper and exposed pipes shall be suitably protected from stones and other objects falling into the trench from above.

The permissible tolerance for pipelines in trenches shall be 6mm in level and 25mm in line between manholes. After the laying of a length of a pipeline but before testing the crown of the pipe shall be checked for level and alignment and any necessary adjustment made by unjointing and removing the pipes concerned, adjusting the bedding, relaying the pipes and rechecking for line and level.

For pipeline jointing systems incorporating flexible jointing rings, pipes shall be laid with the spigot end pointing in the direction of flow and with a gap between the end of the spigot and the base of the socket, or between spigots. Rubber rings shall comply to IS : 5382.

JOINTING

Pipe section shall be joined utilising spigot and socket flexible joint with rubber ring, as per relevant IS after jointing, extraneous material, if any, shall be removed from the inside of the pipe and the newly made joints shall be thoroughly cured. The rubber sealing rings used for jointing, shall conform to IS : 5382.

The RCC pipe with the rubber ring accurately positioned on the spigot shall be pushed well home into the socket of the previously laid pipe by means of uniformly applied pressure with the aid of a jack or similar appliance. The RCC pipes shall be of spigot and socket type and rubber rings shall be used, and the manufacturer's instructions shall be deemed to form a part of these engineer's requirements. The rubber rings shall be lubricated before making the joint and the lubricant shall be soft soap water or an approved lubricant supplied by the manufacturer.

TECHNICAL SPECIFICATION

BEDDING

The type of bedding for the RCC pipes (granular, concrete cradle – PCC, RCC, concrete encasement, etc.).

GRANULAR BEDDING

1. Material used for bedding should be of granular material, free from sharp edges and sharp angles, well graded and durable under influence of ground water. The material selected shall consist of gravel (uncrushed or crushed), crushed rock or crushed concrete. uncrushed gravel is obtained from the natural disintegration of rock.
2. Well graded gravel of varying size from 5 mm to 14 mm shall be used. percentage distribution of each size for graded aggregate is mentioned in table 2.1 below.
3. Where pipes are laid with a granular bed or surround the appropriate bedding material shall, as soon as a section of trench has been trimmed to grade, be placed carefully over the full trench width without segregation. The material shall be spread and thoroughly compacted by approved mechanical means in successive uniform layers each not exceeding 150 mm compacted thickness to produce a uniform bed to the required gradient. where plate vibrators are used, there shall be a minimum of one pass for crushed stone and two passes for sands. hand tamping will only be permitted where insufficient space is available to allow the use of mechanical plant. the minimum thickness of compacted granular material shall be as follows:-
4. 150mm (minimum 100mm under sockets) for pipes not exceeding 300mm nominal diameter, except when trench is in rock.
5. 200mm (minimum 100mm under sockets) for pipes greater than 300mm nominal diameter, or all pipes when trench is in rock.
6. The pipes shall then be set evenly on the bed, great care being taken to ensure uniform support for the entire length of the pipe.
7. Pockets in the bedding shall be formed at each pipe joint to permit jointing to be carried out without the sleeve or socket of the pipe joint bearing on the bedding material and without bedding material entering the joint.
8. After the pipeline alignment and joints have been inspected and approved by the engineer, the water testing of the pipeline satisfactorily completed, and, where appropriate, the annular gap at each pipe joint sealed, each joint pocket shall be carefully filled with granular material and thoroughly compacted up to the same level as the top of the bedding. granular bedding material of the same type shall be placed on both sides of the pipeline in successive uniform layers not exceeding 150mm thick and compacted according to one of the methods given in table 2.2 as agreed with or directed by the engineer. care shall be taken to ensure that no cavities remain under the pipe, and that the pipes are not displaced by differential pressure from either side.
9. When placing and compacting surround material the contractor shall take care not to displace or damage the pipes. the tipping of surround material from ground levels directly onto the pipes shall not be permitted.
10. Unless otherwise detailed on the drawings, for pipes with a full granular surround the granular material shall extend up to a minimum height of 300mm over the crown of the pipes. for rigid pipes unless otherwise detailed, the granular material shall extend up to the springing level of the pipe. the surround shall be completed by the careful placing of selected excavated material in layers not exceeding 150mm thick, thoroughly compacted on both sides of the pipeline to a level at least 300mm above the crown of the pipes.

TECHNICAL SPECIFICATION

11. For pipelines of 600mm diameter or greater the bed should be prepared ahead for approximately two pipe lengths whilst two pipes are being laid and the previous two pipes are receiving side filling. for pipelines less than 600 mm diameter the lengths of each stage shall be agreed with the engineer.
12. If the contractor wishes to use any other method of laying pipes in granular bedding or surround he must submit his proposals in writing to and obtain the approval in writing from the engineer well in advance of the date when he wishes to perform the work.

CONCRETE BEDDING

Concrete shall be grade M 20 unless otherwise detailed on the drawings / BOQ.

The minimum thickness of concrete between the bottom of the pipe and the trench shall be $0.25 \times$ nominal pipe diameter, subject to 150mm minimum, with a minimum 100mm beneath sockets.

The pipes shall be set to correct alignment as detailed below :-

The contractor may use rectangular concrete blocks (two per pipe) made of grade M15 concrete, cast at least 7 days before use, together with pairs of approved hardwood wedges of the same width as the blocks in order to align and support the pipe before concreting. the blocks and wedges shall be of sufficient size and suitably founded on the bottom of the trench to support the pipe adequately without settlement or movement at any stage. the blocks and wedges should be placed near the end of each pipe length and should be left undisturbed during jointing of subsequent pipes and during construction, although the wedges should be removed during placing of the concrete.

Blocks may have thin tie wires cast in to assist in holding down the pipe when the concrete surround is being mechanically vibrated.

After approval of the joints and satisfactory testing of the pipeline a transverse flexible joint shall be formed by insertion of a template of compressible joint filler consisting of bitumen impregnated insulating board as per BS 1142 part 3 or other equally compressible material shaped exactly to the pipe and full extent of the concrete cradle or surround. unless otherwise specified , the thickness of this flexible joint shall be a minimum of 25mm.

For spigot and socket pipes, the flexible joint in the concrete shall be aligned with the face of the socket. For sleeve type and flexible mechanical joints, the flexible joint shall be aligned with one end of the sleeve or mechanical joint. In certain cases, a flexible joint may be required at both ends of the sleeve or mechanical joint. The concrete infill for flexible mechanical joints shall only be placed after the application of the specified protection materials to the joint. no steel reinforcement shall pass through the flexible joint.

Concrete for beddings, surrounds and joint infills shall be placed carefully and uniformly, suitable measures being adopted to ensure that the pipeline is not displaced by differential side pressure or by flotation. Concrete shall be properly compacted with particular care being taken to ensure that no cavities are left underneath the pipe.

TECHNICAL SPECIFICATION

The concrete shall provide a minimum cover to the pipe of 150mm for surrounds.

Concrete beds to pipes of all diameters and surrounds to pipes of one meter diameter or less shall be poured in a single operation. concrete surrounds to pipes over one meter diameter shall normally be poured in two lifts, with a horizontal joint not more than 100mm below the crown of the pipe. concrete shall be prevented from entering pipe joints.

Formwork shall be used for all vertical faces. Side forms should not normally be required, if trench widths specified are such that the concrete bedding / surround will extend the full width of the trench.

All formwork used for forming the concrete bedding shall be removed, unless the written approval of the engineer is given to leave it in place for safety or similar reasons. Where side forms have been required, backfilling shall be proper to fill the voids left on removal of the formwork.

The bedding and surround shall be completed by the careful placing of selected excavated material in layers not exceeding 150mm thick, thoroughly compacted by hand on both sides of the pipeline to a level at least 300mm above the crown of the pipes. as this material is placed and compacted in the trench, the supports to the sides of the trench shall be concurrently partly withdrawn so that there are no voids or uncompacted zones.

Except where otherwise specified or instructed by the engineer, no traffic load may be imposed upon the trench within 72 hours of the placing of the concrete cradle or surround.

If the contractor wishes to use any other method of laying pipes in concrete cradle or surround, he must submit his proposals in writing to and obtain the approval in writing from the engineer well in advance of the date when he wishes to perform the work.

SPECIAL FOUNDATION IN POOR SOIL

Where the formation of the trench is found to consist of material which is unstable to such a degree that in the opinion of the engineer, it cannot be removed and replaced with an approved material thoroughly compacted in place to support the pipe properly, a suitable foundation for the pipes, consisting of piling, timbers or other materials shall be prepared by the contractor and as instructed by engineer.

INSPECTION OF PIPELINES

As soon as the pipeline has been completed from manhole to manhole the contractor shall run through the pipes both backwards and forwards a double disc or solid or closed cylinder 75 mm less in diameter than the internal diameter of pipes.

If as a result of the removal of any obstructions the engineer considers that damages may have been caused to the pipe lines, he shall be entitled to order the stretch to be tested immediately. should such test prove unsatisfactory, contractor shall make good the pipeline and carry out such further tests as are ordered by the engineer.

SITE TESTING

After laying & jointing of RCC pipes is completed the pipe line shall be tested. All equipment for testing shall be supplied by the contractor. damage during testing shall be contractor's responsibility and shall be rectified by him to the full satisfaction of the engineer. water for testing of pipeline shall be arranged by the contractor at his own cost.

TECHNICAL SPECIFICATION

After the joints have been checked by the engineer and before backfilling of the trenches, the entire section of the sewer shall be proved by the contractor to be watertight by filling the pipes with water to the level of 1.50m above the top of the highest pipe in the stretch and heading the water up for a period of one hour. the apparatus used for the purpose of testing shall be approved by engineer, the contractor if required by the engineer shall de-water the excavated pit and keep it dry during the period of testing. The loss of water over a period of 30 minutes shall be measured by adding water from a measuring vessel at regular 10 minutes intervals and noting the quantity required to maintain the original water level. for acceptance of the section of pipeline under test the average quantity added shall not exceed 1 litre/ hour/100 linear meters / 10mm of nominal internal diameter. any leakage including excessive sweating which causes a drop in the test water level in excess of the permitted amount will result in the pipeline being rejected. the contractor will be required to remove and re-lay the pipeline for re-testing.

Water used for the test shall be removed from pipes and not discharged to the excavated trenches.

1.17 Pressure Gauge

All pressure gauges shall be dial type with Borden tube element of SS 316. The dial size shall be of 150 mm diameter and scale division shall be in metric units marked clearly in black on a white dial. The range of pressure gauge shall be 0-10 kg.sq.cm or as specified in BOQ. The pressure gauges shall be complete with isolation cock, siphon tubing, etc.

1.18 Pressure Switches

The pressure switch shall be industrial type single pole double throw electric pressure switch designed for starting or stopping of equipment when the pressure in the system drops or exceeds pre set limits. It shall comprise of a single pole change over switch, below element assembly and differential spindle.

All pressure switches shall have ¼" BSP (F) inlet connection and screwed cable entry for fixing cable gland. All control cabling shall be provided.

1.19 Sprinkler Heads

Sprinkler heads shall be provided at approximate spacing so as to cover 12 sq.mtr. per sprinkler head in case of ordinary hazard & 17 sq.mtr. in case of light hazard. The spacing shall however be in uniformity with the drawings and properly coordinated with electrical fixtures, ventilation ducts and grilles and other services along the ceiling. Sprinkler heads shall be gunmetal quartz bulb type with a temperature rating of 68°C. Sprinkler heads shall be of upright conventional type with fusible link for operation. Sprinkler head shall be approved by the under writers Laboratories (U.L.) or Fire Officers Committee (FOC). The finish shall be as specified in bill of quantities.

Contractor shall install cabinet (fabricated from 16 Gauge M. S. sheets with lockable glass shutters. Shelves for keeping spare sprinklers and spanner at locations approved by the Engineer-in-Charge and given in the schedule of quantities. The contractor shall also give required tools for removing and fixing of different types of sprinkler free of cost as directed by Engineer-in- Charge.

TECHNICAL SPECIFICATION

1.20 Sprinkler System

General:

To supply, install, testing and commissioning of sprinkler system as per drawing and Sprinkler heads spacing shall be in conformity with the drawings and properly coordinated in reflected ceiling with electrical fixtures, ventilation ducts and grills and other services along the ceiling.

Sprinkler heads shall be brass / gunmetal with quartz bulb with temperature rating of 68 degree Celsius. Sprinkler heads shall be of type and quality approved by the local fire brigade authority/NFPA 13. The inlet shall be screwed. Sprinkler heads shall be pendent, recessed or special side type. All sprinklers shall conform to the specifications given by IS, NFPA, FOC, UL & FM.

Pendent /Upright Type Sprinkler Head

Sprinkler heads shall be quartzite bulb type with bulb, valve assembly, yoke and the deflector. The sprinkler shall be of approved make and type with 15 mm nominal diameter outlets.

The bulb shall be made of corrosion free material strong enough to withstand any water pressure likely to occur in the system. The bulb shall be shatter when the temperature of the surrounding air reaches at 68 c.

The nominal bore shall 15 mm diameter and color of liquid shall be as per temperature rating.

Concealed Type / With Rosette Sprinkler Head

Adjustable concealed sprinklers shall be provided as specified in S.O.Q. in areas where an attractive appearance is primary concern. Concealed Sprinkler heads shall be infinitely adjustable for a full 15 mm so as to compensate for uneven ceiling heights & allow adjustment of the sprinkler cover at any timer. The sprinkler shall be of approved make and type with 15 mm nominal diameter outlets.

The bulb shall be made of corrosion free material strong enough to withstand any water pressure likely to occur in the system. The bulb shall be shatter when the temperature of the surrounding air reaches at 68 c.

The nominal bore shall 15 mm diameter and color of liquid shall be as per temperature rating.

Installation Control Valve &Related Equipment's for Sprinkler System

The sprinkler system shall have installation control valve (Flow switch with Isolation Valve and Drain arrangement) along with assemblies at entry of main header in each floor.

Flow Switch

Flow switch shall have a paddle made up of flexible material of the width to fit within the pipe bore. The terminal box shall be mounted over the paddle / pipe through a connecting socket. The switch shall be potential free in either NO or NC position as required. The switch shall be able to trip and make/ break contact on the operation of a single sprinkler head.

TECHNICAL SPECIFICATION

The terminal box shall have connections for wiring to the Fire alarm panel. The seat shall be of stainless steel. The flow switch shall have IP: 55 protections.

The flow switch shall work at a minimum flow rate of 100 LPM. Further, it shall have a retard to compensate for line leakage or intermittent flows.

Butterfly Valve

- a. The Butterfly valve shall be suitable for waterworks and tested to minimum of 16 kg/sq cm Pressure. The valves shall fulfill the requirements of BIS (Indian Standard) BS: 5155 or AWWA C 504, API 609 and MSS-SP-67.
- b. The body shall be of cast iron to IS: 210 in circular shape and of high strength to take the minimum water pressure of 10 kg/sq cm. The disc shall be heavy-duty cast iron with anti-Corrosive epoxy or nickel coating.
- c. The valve seat shall be high grade elastomeric or nitrile rubber. The valve in closed position shall have complete contact between the seat and the disc throughout the perimeter. The elastomeric rubber shall have a long life and shall not give away on continuous applied water pressure. The shaft shall be of ENB grade carbon steel.
- d. The valve shall be fitted between two flanges on either side of pipe flanges. The valve edge rubber shall be projected outside such that they are wedged within the pipe flanges to prevent leakages.
- e. The valve shall be supplied with manual gear operated opening/ closing system by lever.

Drain Valve

50 MM / or as specified in SOQ diameter MS/ G.I. pipe conforming to I.S.:1239 (heavy grade) with 50 mm diameter / or as specified in SOQ gunmetal full way valve shall be provided for drainage of any water in the system in low pockets.

SPRINKLER ALARM VALVE:

Apart from above, Sprinkler alarm valve shall be provided with all accessories for wet sprinkler system to ensure positive water flow. It shall have flange connection & shall have brass body & steel trims. The valve shall conform to the specifications given by NFPA/UL/LFA

1.21 Testing of the hydrant system:

All air shall be trapped from the pipeline through hydrants & air valves. Each section of the pipe shall be slowly filled with the water & allow to stand the water for 2 hours minimum with the ends closed. No joints / connection shall be leaked within this duration. The hydraulic test pressure shall be 1.5 times the design pressure.

Flushing of underground connections: Underground mains and lead-in connections to system risers shall be flushed before connections made to piping in order remove foreign materials which may have entered the underground during the course of installation. For hydrant system the flushing operation shall be continued until water is clear.

TECHNICAL SPECIFICATION

Underground mains and lead-in connection shall be flushed at a flow rate of not less than 480 ltrs. Per minute.

Provision shall be made for the disposal of water issuing from test outlets to avoid property damage

Acceptance Test

At the time of taking over, the hydrant system shall fulfill the following acceptance tests: -

Starting up of the pressure suction (Jockey Pump): The pressure switch shall be set at 3.5 kg/cm² at the lower limit and 7.5 kg/cm² at the upper limit. The system drain shall be opened to cause a drop in the pressure. The Jockey Pump shall start as soon as the pressure gauge needle falls down to 3.5 kg. The Jockey pump shall also stop automatically when the system has been pressurized again upto 7.5kg/cm².

The main electrical pump shall be set to start at 3.5 kg/cm². An external hydrant valve using a single length of hose and branch pipe shall be fully opened to cause a drop of pressure in the system. At first, the jockey pump shall start when the pressure drops from 7 kg. Further, drop in the pressure from 3.5 kg should be allowed to test automatic start-up of the electrical pump. The electrical pump shall continue to run at least for 5 minutes and register rise in the pressure up to 3.5 kg the Jockey Pump shall be automatically start at this. The electrical pump shall be stopped manually by pressing the stop button.

After having the system got fully charged at 7.5 kg/cm² the external hydrant valve using hose and branch pipe at (ii) above shall be opened. When the pressure has dropped from 3.5 kg/cm², the electric main pump shall come into operation automatically. After the main pump has run for 5 minutes, the power supply in the pump house shall be switched off. The diesel pump shall automatically come into operation immediately.

All these tests mentioned above shall be repeated after one-hour interval. The result of all the tests shall be identical again. After the system has satisfactorily withstood the above tests, it can be taken over from the contractor.

1.22 Start-Up/System Testing

It will be the responsibility of the tendered to cause interim/stage inspection by the Local Fire Authority LFA/ Chief Fire Officer C.F.O during execution of the work as and when so called for by the Employer / Consultant and shall carry out any rectification / modification as may be suggested by the Local Fire Authority (LFA), Chief Fire Officer (CFO).

Soon after the work is completed, the contractor shall inform the LFA/CFO in writing with a copy to the Consultant/Employer for getting the complete system including all sub system and instrumentation, control etc. thoroughly inspected and tested for satisfactory performance. After satisfactory completion of tests of the systems by the LFA / CFO, the contractor shall be required to submit as built drawings to the Consultant / OWNER which have been so approved.

Commissioning of System

- a. Pressurized the fire hydrant system by running the main fire pump and after attain required pressure shut off the pump.

TECHNICAL SPECIFICATION

- b. Open bye-pass valve and allow the pressure to drop in the system. Check that the jockey pump cuts-in and cuts-out at the pre-set pressure. If necessary, adjust the pressure switch for the jockey pump. Close bye-pass valve.
- c. Open bye-pass valve and allow the water to flow into the fire water tank in order to avoid wastage of water. The main fire pump should cut-in at the preset pressure and should not cut-out automatically on reaching the normal line pressure. The main fire pump should stop only by manual push button. However, the jockey pump should cut out as soon as the main pump starts.
- d. Switch off the main fire pump and test check the diesel engine driven pump in the same manner as the electrically driven pump.
- e. When the fire pumps have been checked for satisfactory working on automatic controls, open fire hydrant simultaneously and allow the hose pipe to discharge water into the fire tank to avoid wastage. The electrically driven pump should run continuously for eight hours so that its performance can be checked.
- f. Diesel engine / DG set driven pump should also be checked in the same manner as given in Para above by running for 8 hours.
- g. Check each landing valve, male and female couplings and branch pipes for compatibility with each other. Any fitting which is found to be incompatible and does not fit into the other properly, shall be replaced by the Contractor. Landing valves shall also be checked by opening and closing under pressure.

Handing Over

- All commissioning and testing shall be done by the Contractor to the complete satisfaction of the Engineer-in-Charge / Consultants, and the job handed over to the Client.
- Contractor shall also hand over to the Client all maintenance and operation manuals and all items as per the terms of the contract

TECHNICAL SPECIFICATION

1.23 Technical Data Sheet

(Technical information to be furnished in following format by Bidder)

Technical Data Sheet To Be Furnished By Bidder

SR. NO.	SPECIFICATION	DESCRIPTION			
		HYDRANT	SPRINKLER	JOCKEY	WATER CURTAIN
1.0	FIRE PUMP(S)				
1.1	Type(s)				
1.2	Make(s)				
1.3	General Specifications:				
1.3.1	Capacity (Lit/Sec)				
1.3.2	Head in (mtr.)				
1.3.3	Sizes of suction and delivery pipes in mm				
1.3.4	Pump Efficiency				
1.4	Material for Impeller				
1.5	Material for Pump Casing				
1.6	Material for Shaft				
1.7	Electrical Motor				
1.7.1	Type				
1.7.2	Make				
1.7.3	Speed in R.P.M				
1.7.4	H.P and Voltage of driving motor, type of enclosure and class of winding insulation, Motor full load current (Remote controlled starting arrangement, if any)				
1.7.5	Details of electric supply				
1.7.6	Type of Starter				
1.8	Diesel engine (if asked)				
1.8.1	Speed and Horse power of the engine driving pump(s)				
1.8.2	Method of starting the engine				

TECHNICAL SPECIFICATION

SR. NO.	SPECIFICATION	DESCRIPTION			
1.8.3	Fuel Consumption				
1.8.4	Details of batteries, Battery Charger and Diesel Engine control panel				
1.8.5	Make				
2.0	HYDRANT MAINS				
2.1	Material & Type of underground and / or overhead mains with method of joining				
2.2	To what pressure have the pipes been tested?				
2.3	No. & dia. Of wet riser				
3.0	HYDRANT VALVES				
3.1	Type and Make				
3.2	No. & type of Yard hydrants valve				
3.3	No. & type of floor hydrants				
4.0	HOSE				
4.1	Material and diameter				
4.2	Manufacturer's Name and Guarantee for bursting pressure.				
4.3	No. of length of 15m and 7.5m respectively				
4.4	At what pressure the hose has been tested by the insured?				
4.5	Where is hose kept?				
4.6	No. of branch pipes and nozzles and their diameters				
5.0	SPRINKLER				
5.1	No. & type of isolation valves				
5.2	Type, make and fusing temperature of the sprinkler heads used.				

TECHNICAL SPECIFICATION

Note: Performance curve for pumps & catalogues for each above item shall be submitted

1.24 Installation of Engineered Support System

Hydrant and Sprinkler Pipe Support for RCC Slab

The Firefighting pipe should be simply suspended by Sprinkler Clamp having knurled nut.

The Sprinkler Clamp should be pre-galvanized with one-piece design for safe hanging of sprinkler pipes. It should have height adjustable arrangement so as to incorporate the suspended threaded rod.

The Mounting according to static requirements should undertake into account the manufacturer's documents and should be monitored according to VdS or UL /FM Approval.

The riser and hydrant / sprinkler pipe support installation should be as per National Building Code.

The Riser Pipes should be mounted on the support channel with the help of a split clamps DIN 3567.

The support channel should be made up of cold rolled steel of quality DX51 or greater and as per EC3(Eurocode 3) or DIN EN 1993-1-1

The Support channel should be pre-galvanized with minimum GSM of 275 and should have universal mounting slot on the front of the rail for accurate positioning of fasteners and system compatible round and long holes on back of the rail.

The Mounting according to static requirements should undertake into account the manufacturer's documents and should be monitored according to RAL - GZ 655-C

The Threaded Rods used for the suspension of the Pipe should be made up of partially annealed medium carbon steel of grade 4.8 strength class and as per DIN 976 standard.

The Drop-in anchors used for the suspension of the rods should be ETA(EUROPEAN TECHNICAL APPROVAL) with CE mark for cracked and un-cracked concrete.

It should be divided into four expansion segments for uniform pressing force distribution in the borehole.

TECHNICAL SPECIFICATION

The load bearing capacity for the selection of the sprinkler clamp for suitable size of the pipe should be as per Vds and FM guideline provided by the contractor to the consultant for verification.

Maximum Support Spacing (m)					
Nominal Pipe Dia (mm)	Support Distance (M)	Nominal Pipe Dia (mm)	Support Distance (M)	Nominal Pipe Dia (mm)	Support Distance (M)
Upto 15	1.8	65	3.7	250	5.0
20	2.4	80	3.7	300	6.1
25	2.4	100	3.7	350	10.0
32	2.7	125	3.7	400	10.5
40	3.0	150	4.5	450	11.0
50	3.0	200	5.6	500	12.0

Typical Arrangement for sprinkler and hydrant pipe support From RCC slab

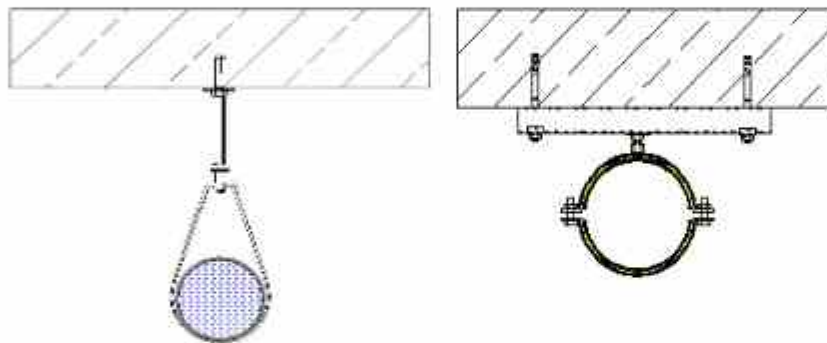

Hydrant and Sprinkler Pipe Support for PEB structure

The Firefighting pipe should be simply suspended by Sprinkler Clamp having knurled nut.

The Sprinkler Clamp should be pre-galvanized with one-piece design for safe hanging of sprinkler pipes. It should have height adjustable arrangement so as to incorporate the suspended threaded rod.

The Mounting according to static requirements should undertake into account the manufacturer's documents and should be monitored according to VdS or UL /FM Approval.

The riser and hydrant pipe support installation should be as per National Building Code.

The Riser Pipes should be mounted on the support channel with the help of a split clamps DIN 3567.

The support channel should be made up of cold rolled steel of quality DX51 or greater and as per EC3(Eurocode 3) or DIN EN 1993-1-1

TECHNICAL SPECIFICATION

The Support channel should be pre-galvanized with minimum GSM of 275 and should have universal mounting slot on the front of the rail for accurate positioning of fasteners and system compatible round and long holes on back of the rail.

The Mounting according to static requirements should undertake into account the manufacturer's documents and should be monitored according to RAL - GZ 655-C

The Threaded Rods used for the suspension of the Pipe should be made up of partially annealed medium carbon steel of grade 4.8 strength class and as per DIN 976 standard.

For parallel to beam application.

The Girder cleat for attachment of support channel to steel girder

Girder cleat should be Vds approved.

For perpendicular to beam application

The Girder clamp for suspension of threaded pins and threaded rods for support channels. Girder clamps should be FM and Vds Approved.

The load bearing capacity for the selection of the sprinkler clamp for suitable size of the pipe should be as per Vds and FM guideline provided by the contractor to the consultant for verification.

Maximum Support Spacing (m)					
Nominal Pipe Dia (mm)	Support Distance (M)	Nominal Pipe Dia (mm)	Support Distance (M)	Nominal Pipe Dia (mm)	Support Distance (M)
Upto 15	1.8	65	3.7	250	5.0
20	2.4	80	3.7	300	6.1
25	2.4	100	3.7	350	10.0
32	2.7	125	3.7	400	10.5
40	3.0	150	4.5	450	11.0
50	3.0	200	5.6	500	12.0

TECHNICAL SPECIFICATION

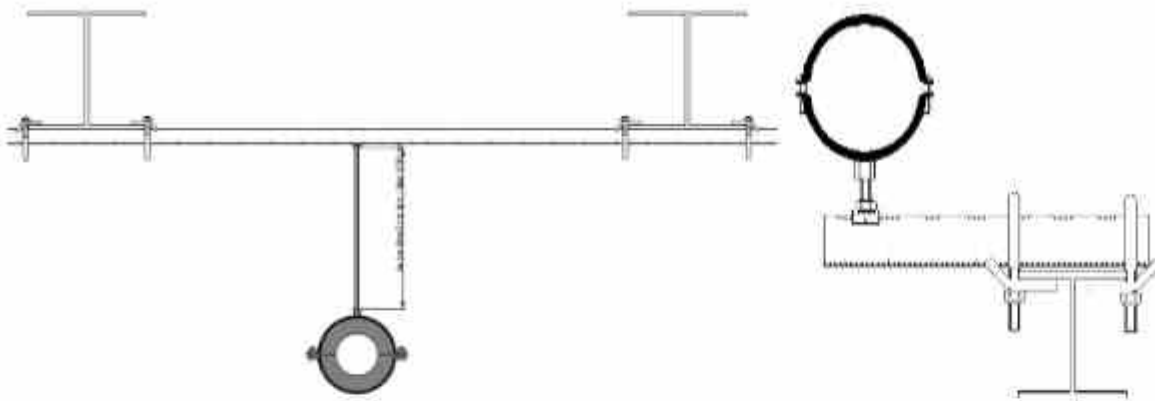

Hydrant Pipe Support for Building Shaft

The Riser Pipes should be mounted on the support channel with the help of a split clamps or STATO BRACKET.

The support channel should be made up of cold rolled steel of quality DX51 or greater and as per EC3(Eurocode 3) or DIN EN 1993-1-1

The riser and hydrant / sprinkler pipe support installation should be as per National Building Code.

The Support channel should be pre-galvanised with minimum GSM of 275 and should have universal mounting slot on the front of the rail for accurate positioning of fasteners and system compatible round and long holes on back of the rail.

The Mounting according to static requirements should undertake into account the manufacturer's documents and should be monitored according to RAL - GZ 655-C

The Threaded Rods used for fixing pipe clamp with support channel that should be made up of partially annealed medium carbon steel of grade 4.8 strength class and as per DIN 976 standard.

The Drop-in anchors used for fixing channel with building shaft that should be ETA(EUROPEAN TECHNICAL APPROVAL) with CE mark for cracked and un-cracked concrete.

It should be divided into four expansion segments for uniform pressing force distribution in the borehole.

TECHNICAL SPECIFICATION

The load bearing capacity for the selection of the sprinkler clamp for suitable size of the pipe should be as per Vds and FM guideline provided by the contractor to the consultant for verification.

Maximum Support Spacing (m)					
Nominal Pipe Dia (mm)	Support Distance (M)	Nominal Pipe Dia (mm)	Support Distance (M)	Nominal Pipe Dia (mm)	Support Distance (M)
Upto 15	1.8	65	3.7	250	5.0
20	2.4	80	3.7	300	6.1
25	2.4	100	3.7	350	10.0
32	2.7	125	3.7	400	10.5
40	3.0	150	4.5	450	11.0
50	3.0	200	5.6	500	12.0

Typical Arrangement for sprinkler and hydrant pipe support From PEB structure

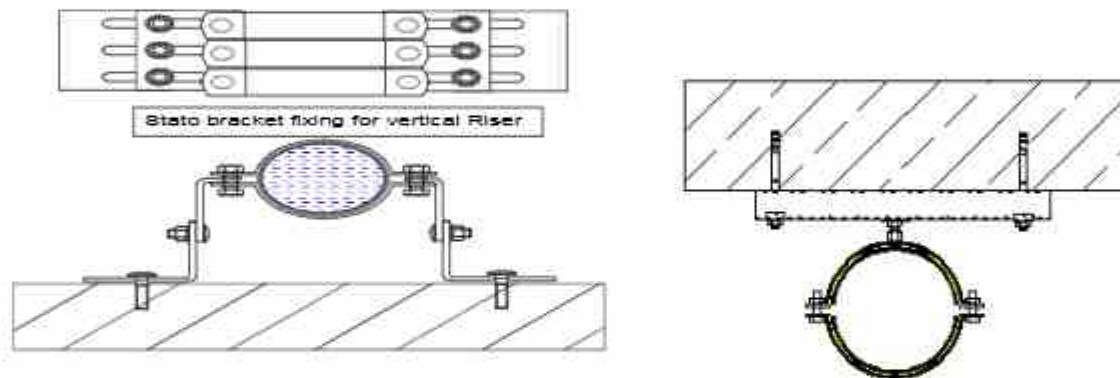

Hydrant Pipe Support for Building Shaft

The Riser Pipes should be mounted on the support channel with the help of a split clamps DIN 3567 or STATO BRACKET.

The support channel should be made up of cold rolled steel of quality DX51 or greater and as per EC3(Eurocode 3) or DIN EN 1993-1-1

The riser and hydrant / sprinkler pipe support installation should be as per National Building Code.

The Support channel should be pre-galvanised with minimum GSM of 275 and should have universal mounting slot on the front of the rail for accurate positioning of fasteners and system compatible round and long holes on back of the rail.

The Mounting according to static requirements should undertake into account the manufacturer's documents and should be monitored according to RAL - GZ 655-C

The Threaded Rods used for fixing pipe clamp with support channel that should be made up of partially annealed medium carbon steel of grade 4.8 strength class and as per DIN 976 standard.

TECHNICAL SPECIFICATION

The Drop-in anchors used for fixing channel with building wall that should be ETA (EUROPEAN TECHNICAL APPROVAL) with CE mark for cracked and un-cracked concrete. It should be divided into four expansion segments for uniform pressing force distribution in the borehole.

The load bearing capacity for the selection of the sprinkler clamp for suitable size of the pipe should be as per TDS and FM guidelines provided by the contractor to the consultant for verification.

Maximum Support Spacing (m)					
Nominal Pipe Dia (mm)	Support Distance (M)	Nominal Pipe Dia (mm)	Support Distance (M)	Nominal Pipe Dia (mm)	Support Distance (M)
Upto 15	1.8	65	3.7	250	5.0
20	2.4	80	3.7	300	6.1
25	2.4	100	3.7	350	10.0
32	2.7	125	3.7	400	10.5
40	3.0	150	4.5	450	11.0
50	3.0	200	5.6	500	12.0

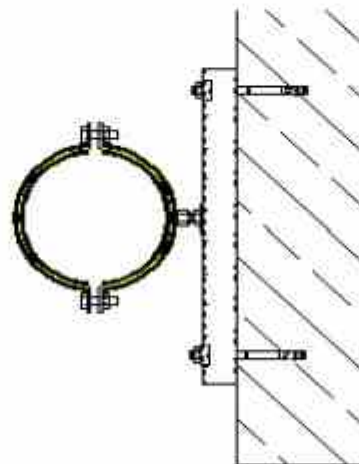

Hydrant and Sprinkler Pipe Support for RCC Slab

The Firefighting pipe should be simply suspended by Sprinkler Clamp having knurled nut.

The Sprinkler Clamp should be pre-galvanized with one-piece design for safe hanging of

TECHNICAL SPECIFICATION

sprinkler pipes. It should have height adjustable arrangement so as to incorporate the suspended threaded rod.

The Mounting according to static requirements should undertake into account the manufacturer's documents and should be monitored according to VdS or UL /FM Approval.

The riser and hydrant / sprinkler pipe support installation should be as per National Building Code.

The Riser Pipes should be mounted on the support channel with the help of a split clamps DIN 3567.

The support channel should be made up of cold rolled steel of quality DX51 or greater and as per EC3(Eurocode 3) or DIN EN 1993-1-1

The Support channel should be pre-galvanized with minimum GSM of 275 and should have universal mounting slot on the front of the rail for accurate positioning of fasteners and system compatible round and long holes on back of the rail.

The Mounting according to static requirements should undertake into account the manufacturer's documents and should be monitored according to RAL - GZ 655-C

The Threaded Rods used for the suspension of the Pipe should be made up of partially annealed medium carbon steel of grade 4.8 strength class and as per DIN 976 standard.

The Drop-in anchors used for the suspension of the rods should be ETA(EUROPEAN TECHNICAL APPROVAL) with CE mark for cracked and un-cracked concrete.

It should be divided into four expansion segments for uniform pressing force distribution in the borehole.

The load bearing capacity for the selection of the sprinkler clamp for suitable size of the pipe should be as per Vds and FM guideline provided by the contractor to the consultant for verification.

Maximum Support Spacing (m)					
Nominal Pipe Dia (mm)	Support Distance (M)	Nominal Pipe Dia (mm)	Support Distance (M)	Nominal Pipe Dia (mm)	Support Distance (M)
Upto 15	1.8	65	3.7	250	5.0
20	2.4	80	3.7	300	6.1
25	2.4	100	3.7	350	10.0
32	2.7	125	3.7	400	10.5
40	3.0	150	4.5	450	11.0
50	3.0	200	5.6	500	12.0

TECHNICAL SPECIFICATION

Typical Arrangement for sprinkler and hydrant pipe support From RCC slab

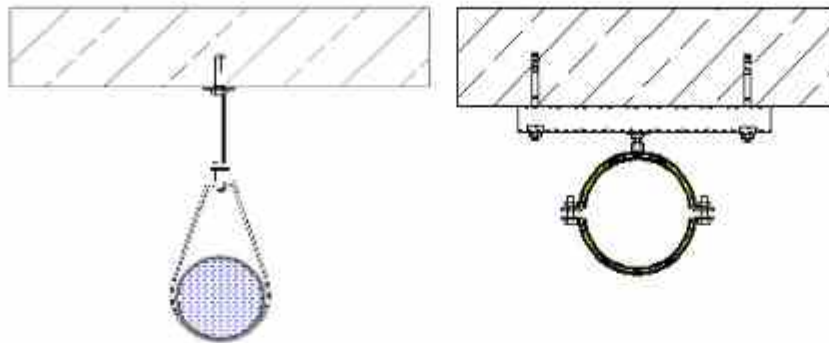

Hydrant and Sprinkler Pipe Support for PEB structure

The Firefighting pipe should be simply suspended by Sprinkler Clamp having knurled nut.

The Sprinkler Clamp should be pre-galvanized with one-piece design for safe hanging of sprinkler pipes. It should have height adjustable arrangement so as to incorporate the suspended threaded rod.

The Mounting according to static requirements should undertake into account the manufacturer's documents and should be monitored according to VdS or UL /FM Approval.

The riser and hydrant pipe support installation should be as per National Building Code.

The Riser Pipes should be mounted on the support channel with the help of a split clamps DIN 3567.

The support channel should be made up of cold rolled steel of quality DX51 or greater and as per EC3(Eurocode 3) or DIN EN 1993-1-1

The Support channel should be pre-galvanized with minimum GSM of 275 and should have universal mounting slot on the front of the rail for accurate positioning of fasteners and system compatible round and long holes on back of the rail.

The Mounting according to static requirements should undertake into account the manufacturer's documents and should be monitored according to RAL - GZ 655-C

The Threaded Rods used for the suspension of the Pipe should be made up of partially annealed medium carbon steel of grade 4.8 strength class and as per DIN 976 standard.

TECHNICAL SPECIFICATION

For parallel to beam application.

The Girder cleat for attachment of support channel to steel girder

Girder cleat should be Vds approved.

For perpendicular to beam application

The Girder clamp for suspension of threaded pins and threaded rods for support channels.
Girder clamps should be FM and Vds Approved.

The load bearing capacity for the selection of the sprinkler clamp for suitable size of the pipe should be as per Vds and FM guideline provided by the contractor to the consultant for verification.

Maximum Support Spacing (m)					
Nominal Pipe Dia (mm)	Support Distance (M)	Nominal Pipe Dia (mm)	Support Distance (M)	Nominal Pipe Dia (mm)	Support Distance (M)
Upto 15	1.8	65	3.7	250	5.0
20	2.4	80	3.7	300	6.1
25	2.4	100	3.7	350	10.0
32	2.7	125	3.7	400	10.5
40	3.0	150	4.5	450	11.0
50	3.0	200	5.6	500	12.0

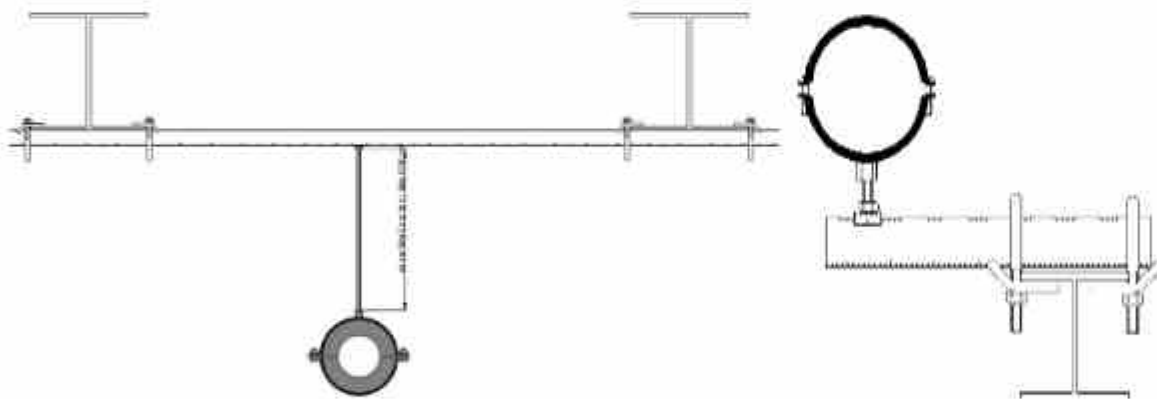

Hydrant Pipe Support for Building Shaft

The Riser Pipes should be mounted on the support channel with the help of a split clamps or STATO BRACKET.

The support channel should be made up of cold rolled steel of quality DX51 or greater and as per EC3(Eurocode 3) or DIN EN 1993-1-1

The riser and hydrant / sprinkler pipe support installation should be as per National Building

TECHNICAL SPECIFICATION

Code.

The Support channel should be pre-galvanised with minimum GSM of 275 and should have universal mounting slot on the front of the rail for accurate positioning of fasteners and system compatible round and long holes on back of the rail.

The Mounting according to static requirements should undertake into account the manufacturer's documents and should be monitored according to RAL - GZ 655-C

The Threaded Rods used for fixing pipe clamp with support channel that should be made up of partially annealed medium carbon steel of grade 4.8 strength class and as per DIN 976 standard.

The Drop-in anchors used for fixing channel with building shaft that should be ETA (EUROPEAN TECHNICAL APPROVAL) with CE mark for cracked and un-cracked concrete.

It should be divided into four expansion segments for uniform pressing force distribution in the borehole.

The load bearing capacity for the selection of the sprinkler clamp for suitable size of the pipe should be as per TDS and FM guidelines provided by the contractor to the consultant for verification.

Maximum Support Spacing (m)					
Nominal Pipe Dia (mm)	Support Distance (M)	Nominal Pipe Dia (mm)	Support Distance (M)	Nominal Pipe Dia (mm)	Support Distance (M)
Upto 15	1.8	65	3.7	250	5.0
20	2.4	80	3.7	300	6.1
25	2.4	100	3.7	350	10.0
32	2.7	125	3.7	400	10.5
40	3.0	150	4.5	450	11.0
50	3.0	200	5.6	500	12.0

Typical Arrangement for sprinkler and hydrant pipe support From PEB structure

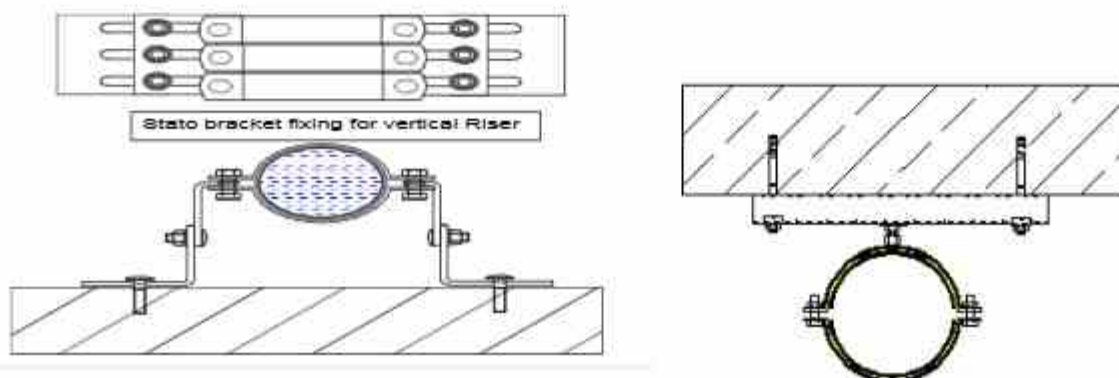

TECHNICAL SPECIFICATION

Hydrant Pipe Support for Building Shaft

The Riser Pipes should be mounted on the support channel with the help of a split clamps DIN 3567 or STATO BRACKET.

The support channel should be made up of cold rolled steel of quality DX51 or greater and as per EC3(Eurocode 3) or DIN EN 1993-1-1

The riser and hydrant / sprinkler pipe support installation should be as per National Building Code.

The Support channel should be pre-galvanized with minimum GSM of 275 and should have universal mounting slot on the front of the rail for accurate positioning of fasteners and system compatible round and long holes on back of the rail.

The Mounting according to static requirements should undertake into account the manufacturer's documents and should be monitored according to RAL - GZ 655-C

The Threaded Rods used for fixing pipe clamp with support channel that should be made up of partially annealed medium carbon steel of grade 4.8 strength class and as per DIN 976 standard.

The Drop-in anchors used for fixing channel with building wall that should be ETA(EUROPEAN TECHNICAL APPROVAL) with CE mark for cracked and un-cracked concrete. It should be divided into four expansion segments for uniform pressing force distribution in the borehole.

The load bearing capacity for the selection of the sprinkler clamp for suitable size of the pipe should be as per TDS and FM guidelines provided by the contractor to the consultant for verification.

Maximum Support Spacing (m)					
Nominal Pipe Dia (mm)	Support Distance (M)	Nominal Pipe Dia (mm)	Support Distance (M)	Nominal Pipe Dia (mm)	Support Distance (M)
Upto 15	1.8	65	3.7	250	5.0
20	2.4	80	3.7	300	6.1
25	2.4	100	3.7	350	10.0
32	2.7	125	3.7	400	10.5
40	3.0	150	4.5	450	11.0
50	3.0	200	5.6	500	12.0

TECHNICAL SPECIFICATION

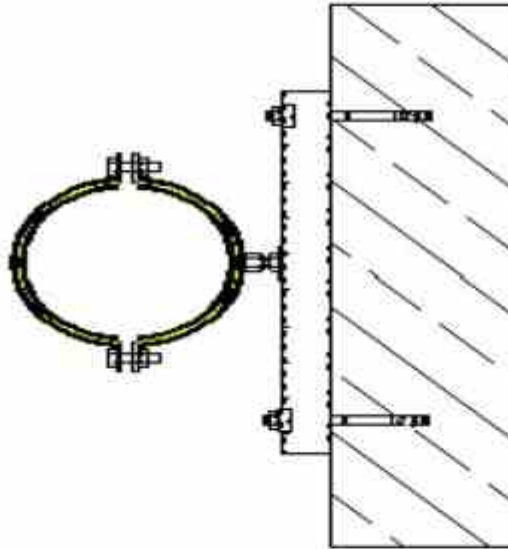

1.25 Fire Bucket:

Galvanized mild steel fire bucket with ISI mark as per IS 2546-1974. The shape and the essential dimensions of fire bucket shall conform to IS 2546-1974. fire buckets (3 nos./set) of 24-gauge galvanized steel sheet, standard 9 litre capacity and of round bottom shape, painted white inside and black on the bottom, inscribed with letters " FIRE" in black and gold with dry clean fire sand. The scope shall also include the stand for mounting the sand bucket.

MANUFACTURE

Body — The body shall be in two halves which shall be joined together by butt welding. The top rim of the body shall be wired and uniformly beaded. The beading shall be fully formed without gaps. The thickness of body shall be 1 mm and diameter of beading wire 3.55 mm

Bottom — The bottom shall be dished and shall be joined to the body by butt welding so that there is no raw edge or crevice on the inside of the bucket. The thickness of the bottom sheet shall be 1 mm.

Ears — The ears shall be made of mild steel sheet and shall be fitted to the body at the top by means of welding with the flat head on the side. The thickness of sheet for ears shall be 2.8 mm

Top Handle — The top handle shall be of mild steel rod of 10 mm in diameter with its ends bent up.

Bottom Handle — The bottom handle shall be of mild steel rod of 10 mm in diameter and it shall be joined to the bottom by welding as shown in Fig. 1. The grip shall have no sharp edges.

General — All gas welds shall be free from porosity, blow holes and brittleness.

FINISH

TECHNICAL SPECIFICATION

- All parts of the bucket shall be finished smooth and sharp edges rounded off.
- The bucket shall be galvanized after manufacture as per IS : 2629-1966*. The thickness of coating of zinc conforming to IS: 13229-1991 Specification for zinc for galvanizing on any portion shall be not less than 0.06 g/cm² (both sides inclusive). Alternately, it may also be galvanized of lead tin alloy to a thickness of not less than 0.012 mm.
- Bucket shall, in addition to galvanizing, be painted with two coats of white paint on the inside and two coats of red paint on the outside (see also 2.4). The handles and the ears shall be painted with two coats of black paint.
- The word 'FIRE' shall be painted in black centrally on the outside; its letters shall be 75 mm high, and approximately 12 mm thick.

1.26 Gunmetal orifice plates:

Specially designed gunmetal orifice plates (minimum 8 mm plate thickness) on hydrant outlets of landing valves including distant pieces of suitable size for reducing delivery pressure up to 3.5 kg/ sq.cm at hydrant valve , as required by LFA complete with necessary accessories, etc.

Scope:

Supplying and erecting one no Brass orifice plate having 6 mm. thick with specified outer diameter and suitable inner diameter to reduce the pressure as per requirement.

Material:

Body: Gunmetal 8 mm thick

Method of construction: The orifice plate shall be placed before the hydrant valve.

Mode of Measurement:

Executed quantity shall be measured on number basis

1.27 Air release valve:

Scope:

Supplying and erecting Air release cock 25 mm dia made from gunmetal with necessary G.I. coupling for fixing on top of air vessel or on wet riser with 25 mm dia ball valve on inlet side and pressure gauge with isolating cock.

Material:

Air release valve: Gun metal

TECHNICAL SPECIFICATION

Coupling: G.I

Method of Construction:

Air release valve with necessary GI coupling shall be fixed on top of wet riser with required labour, tools, etc.

Mode of Measurement:

Executed quantity shall be measured on number basis.

Signages:

Providing & Fixing AUTOGLOW Signages in Block / Small Letters of Specified Sizes in BOQ. Signages shall be as per IS 12349-1988. The colour red, green and yellow, shall conform to Shade No. 536, 221 and 309 of IS: 5-1978. Colours for ready mixed paints and enamels (third revision) respectively. The paint shall conform to IS: 2932-1974 'Specification for enamel, synthetic, exterior (a) undercoating, (b) finishing (first revision).

1.28 Reflux Valve (Non-Return Valve)

Specifications shall conform to IS – 5312 or its latest update.

MATERIALS - The materials used for the manufacture of different component parts shall conform to the requirements given in IS 5312 – 2004 or its latest update.

Materials of Construction

Sr. No.	Component	Material
(a)	Body, cover, door, bearing holder and Doors/Disc/Plate	Grey Cast Iron ; IS 210 Gr. FG 260
(b)	Hinge Pin/ Door Pin and Door Suspension pin	Stainless steel; IS 6603
(c)	Body Seat rings	Leaded tin bronze, IS 318
(d)	Door Face ring	Leaded tin bronze
(e)	Bearing Bushes / Bearing Block	Leaded tin bronze
(f)	Plugs for hinge pin/ Air release plug	Leaded tin bronze
(g)	Bolts	Carbon Steel, IS 1363
(h)	Nuts	Carbon Steel, IS 1363
(i)	Gaskets	Rubber, IS 638
(j)	Hinges	Grey Cast Iron, IS 10

TECHNICAL SPECIFICATION

DESIGN AND MANUFACTURE -

Body - The body may be made in two parts - inlet shell and outlet shell. The inlet shell shall have duck foot support.

Diaphragm - Diaphragm shall be fitted between inlet and outlet shells. The parts in the diaphragm should be so designed as to induce minimum headloss in the flow through the valve.

Water Way Area - The area of the waterway through the multi- doors in the diaphragm shall not be less than the bore area except that this area may be reduced by not more than 15 percent for any proprietary designs.

Inlet and Outlet Shell Connections - The attachment of the inlet to outlet shell of the body shall be adequate to withstand the appropriate test pressures, service conditions and the mechanical loads encountered in the operation. All valves shall have bolted connection. Size of the bolts or studs shall not be less than 22 mm.

Seats - Seat rings shall be so fitted as to avoid their becoming loose in service. Standard countersunk screws shall not be used. 6.6 Door - The door shall be integral with the hinge and shall have a flat seating face.

Lugs - Suspension lugs shall be cast integrally on the diaphragm plate and shall be of adequate strength.

Number of Doors - The minimum number of doors (discs) in the diaphragm plate shall be two.

By-Pass Connection - By-passes are not standard items on valves to the design, but if required, it is recommended that they shall be made for connection between the inlet and outlet shell of the valve. By-passes shall conform to PN 1 of IS : 780-1984* and the minimum size of the by-pass arrangement shall be as indicated in respective IS.

COATING - All coatings shall be carried out after satisfactory testing of the valves prior to dispatch. All the un-machined ferrous surfaces of the valve (both inside and outside) shall be thoroughly clean, dry and shall be free from rust and grease before painting. All exposed machined ferrous surfaces shall be painted with one coat of aluminum red oxide primer. Two coats of black Japan conforming to Type B of IS 341 or paint conforming to IS9862 or IS2932

TECHNICAL SPECIFICATION

shall be applied by brush or spray for exterior application in colour as approved by the purchaser.

TESTING – Each valve shall be subjected to following hydrostatic tests as specified in IS.

Hydrostatic Body Test

Hydrostatic Seat Test

INSPECTION – The purchaser or his authorized representative shall have free access to the works of the manufacturer at all reasonable times to inspect the valve at any stage of manufacture and to reject any material which does not conform to the specified requirements.

MARKING – Following information shall be cast on each valve body in raised letter)

- a) Manufacturer's name or trade-mark;
- b) Nominal pressure of valve (PN1.0 or PN1.6);
- c) Size of valve, mm;
- d) Direction of flow; and
- e) Heat No. of cast.

BIS Certification Marking – Each valve may also be marked with the Standard Mark.

Lowering and jointing in position

Supply of Material

- a. Cast Iron double-flanged valves with two tailpieces suitable to pipe conforming to the latest relevant IS shall be supplied and carted by the contractor to the site of work including loading, unloading and stacking at site.
- b. The valves and tailpieces shall be examined before laying for cracks and other flaws. They shall be undamaged in all respect.
- c. The valves shall be cleaned before laying.
- d. All grits and foreign materials shall be removed from the inside of the valves before placing.
- e. All the four faces shall be thoroughly cleaned and coated with a thin layer of mineral grease.

TECHNICAL SPECIFICATION

- f. The tightening of gland shall be checked with a pair of inside-calipers. Clearance between the top of stuffing box and the underside of the gland shall be uniform all the sides.

Jointing Material

- a. The contractor shall provide all necessary jointing materials such as nuts bolts, rubber packing, white zinc, jute, lead wool etc.
- b. All tools and instruments, which are to be required for installation of sluice valve shall be provided by the contractor.
- c. All jointing materials shall be got approved from the engineer-in-charge before use.
- d. The nuts and bolts shall conform to the relevant IS.
- e. The rubber packing shall conform all specifications as narrated in respective IS.

Installation

- a. The valve shall be lowered in to the trench carefully, so that no part is damaged during lowering operation.
- b. If necessary tailpieces shall be fitted with sluice valve first outside the trench and then lowered in to the trench.
- c. The rubber packing shall be three ply and of approved thickness. The packing shall be of full diameter of the flange with necessary holes and the sluice valve bore. It shall be even at both the inner and outer edges.
- d. The flange faces thoroughly greased.
- e. If flange faces are not free, the contractor shall use thin fibers of lead wool.
- f. After placing the packing, nuts and bolts shall be inserted and tightened to make the joint.
- g. The valve shall be tightly closed when being installed to prevent any foreign materials from getting in between the working parts of the valve.
- h. Each flange bolt shall be tightened a little at a time taking care to tighten diametrically opposite bolts alternatively.

TECHNICAL SPECIFICATION

- i. The valve shall be installed in such a way that its Spindle shall remain in truly vertical position.
- j. The otherend of tailpiece shall be fitted with pipes so that continuous lines can work.
- k. Extra excavation required for facility of lowering and fixing valve shall not be paid for.

Testing

- a. After installation of valve the same is tested to 1½ times of its test pressure or as specified in the IS.
- b. The joints of valve shall withstand the test pressure of pipelines.
- c. Defects noticed during test and operation of valve shall be rectified by the contractor at his own cost without any extra claim to the entire satisfaction of the Engineer-in-charge.

Measurement and payment:

The rate shall be paid as per Schedule of Payment per number of valves fixed and tested as directed.

1.29 Air vessel:

Scope

Supplying and installing Air vessel of 600 mm dia 2.0 meter. In height M.S. Tank fabricated from M.S. Black ERW pipe, conforming to IS 3589, having 6 mm thickness, dish end at both ends, duly welded with 300 mm dia pipe, having inlet of 100 mm dia, duly fitted with 100 dia sluice valve and 20/25 mm dia draw in with G.M. gate valve to be installed inside pump house along with provided M.S, angle tripod.

Material:

Air Vessel: MS ERW pipe confirming to IS 3589

Tripod: MS angle of size 75 X 75 X 5mm

Method of construction

300mm dia, 1.5meter height air vessel, Gate valve, flanges, MS angle Tripod including necessary labour, and use of required tools and plants

TECHNICAL SPECIFICATION

1.30 Strainer:

Y-Type Strainers with ISI marked are used for filtering out the dirt, rust, and other debris in the water flow protecting the piping equipment such as pumps, meters, valves, and other equipment in the piping system. All strainers are equipped with a retainer cap which allows easy access to the stainless steel screen for cleaning. Y-Type Strainer flanges are Ductile Iron ANSI B16.1, Class 125, with a maximum water working pressure of 300 psi (20.7 bar). ANSI B16.42, Class 125 flanges are not compatible with ANSI Class 250 or Class 300 flanges.

BODY Ductile iron conforming to ASTM A-536, Grade 65-45-12

SCREEN AISI 304

COATING Fusion Bond Epoxy Coating (RAL 3000)

APPROVALS UL Listed

MODEL Flanged Type: YSF Grooved Type: YSG (Refer Table-I)

WEIGHT Refer Table-II

1.31 Expansion Bellow:

SCOPE:

Design, fabrication, testing and installation of ISI marked metallic expansion bellows with necessary hardware to be provided at suction & delivery side of each pump and on header or as per drawing.

GENERAL:

Expansion bellows shall be designed as per the details furnished in the data sheet and shall be in accordance with the EJMA / ASME standard. All expansion bellows shall be free from dirt, moisture, grease, oil, etc. and all reports for hydrostatic test shall be furnished. Fatigue life expectancy to be considered for the bellows is 7000 cycles.

The bellows shall be metallic corrugated design and shall have double flange. The material for Bellows shall be SS 304.

CLEANING:

TECHNICAL SPECIFICATION

Prior to factory inspection, all manufacturing waste such as metal chips debris and all other foreign material shall be removed from interior of bellows. All mill scale, rust, oil, grease, chalk and all other deleterious material shall be removed from the interior and exterior surfaces.

PAINTING:

Bellows shall first be given two coats of zinc base primer after completely cleaning the surface and then it shall be coated with three coats of coal tar epoxy paint. The resulting coating shall be uniform and smooth and shall adhere perfectly to the surface.

Bellows used in pipes carrying water, the inside coating shall not contain any constituent soluble in water or any ingredient which could impart any taste or odour to the water.

TESTS AND INSPECTION:

1. Bellows shall be tested as per the relevant Standards with latest revisions.
2. Bellows shall be offered for visual inspection and dimensional checks.
3. The hydrostatic and water tightness testing shall be witnessed by the Client.

TENDER DRAWINGS:

The Dimensional drawings with material of construction shall be submitted by tenderer along with their offer.

1.32 Ball Valves:

Forged Brass Ball Valves (For cold/Hot Water)

SCOPE

The item includes provision of forged brass ball valves with hard chrome plated steel ball tested to a pressure not less than 15 kg/cm² with threaded or flanged joints including fixing and testing.

MATERIAL

All ball valves shall be heavy duty of approved make.

Valves shall have suitable for pressure of PN 15.

Ball valves up to 80 mm shall have forged brass body, SS spindle & Teflon seat rings.

Ball valve shall conform to IS: 9890 or BS: 1868.

Full way lever operated forged brass ball of brass body with forged brass hard chrome plated steel ball tested to a pressure not less than 15 kg/cm² with threaded or flanged joints.

TECHNICAL SPECIFICATION

The weight of the full way valve shall be as per the table given below with a tolerance of 5 percent. For Hot water the same shall be suitable for temperature upto 85° C.

The valves shall have either screwed ends or flanged ends.

Diameter In mm	Flanged arch (Kg)	Screwed arch (Kg)
15	1.021	0.567
20	1.503	0.680
25	2.495	1.077
32	3.232	1.559
40	4.082	2.268
50	6.691	3.232
65	10.149	6.804
80	13.381	8.845

FIXING

- The valves shall be fixed in position in the pipeline as shown in the drawing or as directed with necessary socket or union, nuts, flanges, hardware, gaskets, tail piece, etc.
- During installation, flow direction on the valve shall be checked.
- Valves shall be preferably installed in horizontal position with adequate supports.

TESTING

The valves shall be body & seat tested at manufacturer's works as per the relevant standard & duly stamped. Test certificate shall be submitted for material & hydraulic testing.

After fixing in the pipelines, the system shall be hydraulically tested for 1.5 times working pressure or 22.5 kg/cm² whichever is higher for minimum 4 hrs without any pressure drop. In case of leakage, contractor shall rectify/replace valves at his own cost

Valves shall also be tested for its hand wheel / lever function by frequent on-off operation.

1.33 MCC For Fire Pumps:

Design, manufacture, supply, installation, testing and commissioning of star delta starter control panels suitable for 415V, 3 phase, 4 wire, 50 hz power distribution system. The control panel shall consist of the respective Breaker, contactor, Overload relay and other required components to finish satisfactory work. Control panel should be communicated with pressure switch. Necessary integration between control panel and pressure switch shall be

TECHNICAL SPECIFICATION

part of scope. All components in the control panel shall be as per type 2 coordination of respective OEM. (Cost of wiring with pressure switches / switching on and switching off the pumps locally and remotely as per the drawing and as per local CFO requirement).

Cubicle type switchboards and components shall conform to the requirements of the latest revision including amendments of the following codes and standards.

- IS: 8623 Specification for factory-built assemblies of switchgear and control gear for voltage up to and including 1000V AC / 1200V DC.
- IS: 4237 General requirements for switchgear and control-gear for voltage not exceeding 1000-V.
- IS: 2147 Degree of protection provided by enclosure for low voltage switch gear and control-gear.
- IS: 1018 Switchgear and control-gear selection/installation and maintenance.
- IS: 6005 Code of Practice for phosphate of iron and steel.
- IS: 13947-2004/ IEC 947 – 1989 Air circuit breaker / molded case circuit breaker.
- IS: 1248 Direct acting indicating analogue electrical measuring instruments and testing accessories.
- IS: 2705 Part - I, II & III 1964 Current transformers for metering and protection with classification burden ad insulation.
- IEC/EN 60947-2 Motor Protection Circuit Breaker

1.34 Cable Gland, Lugs, XLPE Armoured Cable:

Scope of Work

This section shall cover supply, laying, testing and commissioning of medium voltage XLPE cables.

This specification gives the general requirement of cables. However, it is the responsibility of the vendor to take the joint measurement and obtain client's approval before the placement of orders to the main supplier / manufacturer.

- Codes & Standards

TECHNICAL SPECIFICATION

The following standards and rules shall be applicable:

Item No	Item	Relevant IS	Relevant IEC
1	XLPE insulated electric cables (heavy duty).	IS : 7098 Part I	
2	Recommended current ratings for cables.	IS : 3961	
3	Aluminium conductors for insulated cables	IS : 8130	Indian Electricity Act and Rules.

- Design Basis & Site Conditions

All equipment and materials will be selected and rated for use as per site conditions.

- Technical Requirements

- General Constructional Features

The medium voltage cables shall be supplied, laid, connected, tested and commissioned in accordance with the drawings, specifications, relevant Indian Standards specifications, manufacturer's instructions. The cables shall be delivered at site in original drums with manufacturer's name, size, and type, clearly written on the drums

- Material

Medium voltage cable shall be XLPE insulated, PVC sheathed, aluminum or copper conductor, armoured conforming to IS: 7098 Part I.

a) Type

The cables shall be circular, multi core, annealed copper or aluminum conductor, XLPE insulated and PVC sheathed, armoured or unarmoured.

b) Conductor

Uncoated, annealed copper / aluminum, of high conductivity up to 4mm.² size, the conductor shall be solid and above 4mm.², conductors shall be concentrically stranded as per IEC: 228.

TECHNICAL SPECIFICATION

c) Insulation

XLPE rated 70° c. extruded insulation

d) Core Identification

Two core	:	Red and Black
Three core	:	Red, Yellow and Blue
Four core	:	Red, Yellow, Blue and Black
Single core	:	Green, Yellow for earthing

Black shall always be used for neutral.

e) Assembly

Two, three or four insulated conductors shall be laid up, filled with non-hygroscopic material and covered with an additional layer of thermoplastic material.

f) Armour

Galvanized steel flat strip / round wires applied helically in single layers complete with covering the assembly of cores.

For cable size up to 25 Sq. mm. : Armour of 1.4 mm dia G.I. round wire

For cable size above 25 Sq. mm. : Armour of 4 mm wide 0.8 mm thick G.I strip

g) Sheath

XLPE 70 deg.c. rated extruded.

Inner sheath shall be extruded type and shall be compatible with the insulation provided for the cables.

The outer sheath shall be of an extruded type layer of suitable PVC material compatible with the specified ambient temp. 50 deg. C and operating temperature of cables. The sheath shall be resistant to water, ultraviolet radiation, fungus, termite, and rodent attacks. The color of the outer sheath shall be black, it should conform water swellable coating tape which should protect against saline water.

Sequential length marking required at every 1.0 mtr. interval on outer sheath
Vendor has to furnish resistance / reactance / capacitances of the cable

TECHNICAL SPECIFICATION

a) Rating: Up to and including 1100 Volts.

- Drawings & Information

Contractor shall submit the as built drawing of the cable laying drawing.

Handing over Documents

The supplier shall submit following:

1. Data sheet indicating results of tests
2. Test reports

- Inspection and Testing

All cables shall be adequately protected against any risk of mechanical damage to which they may be liable in normal conditions of handling during transportation, loading, unloading etc.

The cable shall be supplied in single length i.e. Without any intermediate joint or cut unless specifically approved by the client.

The cable ends shall be suitably sealed against entry of moisture, dust, water etc. with cable compound as per standard practice.

Finished Cable Tests at Manufacturer's Works

The finished cables shall be tested at manufacturer's works. Following routine tests for each and every length of cable and copy of test results shall be furnished for each length of cable along with supply. If specified, the cables shall be tested in presence of client's representative.

a) Voltage Test

Each core of cable shall be tested at room temperature at 3 KV A.C. R.M.S. for duration of 5 minutes.

b) Conductor Resistance Test

The D.C. Resistance of each conductor shall be measured at room temperature and the results shall be corrected to 20° c. to check the compliance with the values specified in IS 8130 - 1976.

TECHNICAL SPECIFICATION

Cable Test Before and After Laying of Cables at Site

- a) Insulation Resistance test between phases and phase to Neutral and phase to earth.
- b) Continuity test of all the phases, neutral and earth continuity conductor.
- c) Sheathing continuity test.
- d) Earth resistance test of all the phases and neutral.
- e)

Method of Measurement

The cables will be measured in meters. The unit rate shall include cutting the cable into required lengths, packing, loading, unloading, insurance, transportation, delivery to stores/site as per work order, stocking in stores, testing of cables at stores etc. of medium voltage cable. Total quantity in meters shall be measured lug to lug basis.

Transport, Delivery and Storage

The cable shall be supplied in the actual length as per detailed purchase order.

The cable shall be dispatched at client's stores or at site as per detailed instructions given by client at later stage.

The cable shall be loaded from the main vendor's store and properly stacked as per instruction of client's local representative. All such labour and transportation charges shall be clearly mentioned in the offer.

- Guarantee of Performance.

The quotes values of parameters shall be within given tolerance for given period of service life.

INSTALLATION OF CABLE NETWORK:

Cable network shall include power, control and lighting cables which shall be laid in underground trenches, hume pipe open trenches, cable trays, G.I. pipes, or on building structures as detailed in the relevant drawings, cable schedules or as per the client / consultant's instructions. Supply & installation of cable trays, G.I. pipes / conduits, cable glands and sockets of both end isolators, junction boxes, remote push button stations, etc. shall be under the scope of the contractor.

General requirements for handling cables:

- Before laying cables, this shall be tested for physical damage, continuity, absence of cross phasing, insulation resistance to earth and between

TECHNICAL SPECIFICATION

conductors. Insulation resistance tests shall be carried out with 500 / 1000 V megger.

- The cables shall be supplied at site, wound on wooden drums as far as possible. For smaller length and sizes, cables in properly coiled form can be accepted. The cables shall be laid by mounting the drum of the cable on drum carriage. Where the carriage is not available, the drum shall be mounted on a properly supported axle, and the cable laid out from the top of the drum. In no case the cable will be rolled on as it produces kinks which may damage the conductor.
- Sharp bending of cable shall be avoided. The bending radius for PVC insulated and sheathed, armoured cable shall not be less than 10 D, where "D" is overall diameter of the cable.
- While drawing cables through G.I. pipes, conduits, RCC pipes, ensure that size of pipe is such that, after drawing cables, 40% area is free. After drawing cables, the end of pipe shall be sealed with cotton / bituminous compound.
- High voltage (11 KV and above), medium voltage (240 V and above) and other control cables shall be separated from each other by adequate spacing or running through independent pipes / trays.
- Armoured cables shall never be concealed in walls / floors / roads without G.I. pipes, conduits or RCC pipes.
- Joints in the cable throughout its length of laying shall be avoided as far as possible and if unavoidable, prior approval of site engineer shall be taken. If allowed, proper straight through epoxy resin tight joint shall be made, without any additional cost.
- A minimum loop of 3 mtr. shall be provided on both ends of the cable, and on both ends of straight through cable joint. This additional length shall be used for fresh termination in future. Cable for this loop shall be paid for supply and laying.
- Cable shall be neatly arranged in the trenches / trays in such manner so that criss-crossing is avoided and final take off to the motor / switchgear is facilitated. Arrangement of cable within the trenches / trays shall be the responsibility of the contractor.
- All cable routes shall be carefully measured and cable cut to the required lengths and undue wastage of cables to be avoided. The routes indicated in the drawings is indicative only and the same may be rechecked with the client / consultant before cutting of cables. While selecting cable routes interference with structures, foundations, pipelines, future expansion of buildings etc. should be avoided.

TECHNICAL SPECIFICATION

- All temporary ends of cables must be protected against dirt and moisture to prevent damage to the insulation. For this purpose, ends of all PVC insulated cables shall be taped with an approved PVC or rubber insulating tapes. Use of friction type or other fabric type tape is not permitted. Lead sheathed cables shall be plumbed with lead alloy.
- Wherever cable rises from underground / concrete / masonry trenches to motors / switchgears / push buttons, these shall be taken in G.I. pipes of suitable size, for mechanical protection up to 300 mm. distance of concerned cable gland or as instructed by the client / consultant.
- The cable pass through foundation / walls of other underground structures, the necessary ducts for opening will be provided in advance for the same. However, should it become necessary to cut holes in existing foundation of structures the electrical contractor shall determine the location and obtain approval of the client / consultant before cutting is done.

LAYING OF CABLES (UNDERGROUND SYSTEM)

Cables shall be so laid in trench that this will not interfere with other underground structure. All water pipes, sewage lines or other structures which become exposed by excavation shall be properly supported and protected from injury until the filling has been rammed solidly in places under and around them. Any telephone or other cables coming in the way are to be properly shielded / diverted as directed by the owner / consultant.

- Cable shall be laid at minimum depth of 750 mm. in case of L.T. and 1200 mm. in case of H.T. from ground level. Excavation will be generally in ordinary alluvial soil. The width of trench shall be sufficient for laying of required no. of cables.
- Sand bedding 75 mm. thick shall be made below and above the cables. Layer of bricks (full size) shall be laid above sand bedding on the sides and above the of cables to cover cable completely. More than one cable can be laid in the same trench by providing a brick on edge between two cables. However, the relative location of cables in trench shall be maintained till termination. The surface of the ground after back filling the earth shall be made good so as to conform in all respects to the surrounded ground and to the entire satisfaction of the client / consultant.
- For all underground cables, route markers should be used :
 - a) Separate route markers should be used for LT, HT and telephone cables.

TECHNICAL SPECIFICATION

- b) Route markers should be grounded in ground with 1:2:4 cement concrete pedestal size 230 x 230 x 300 mm.
- b) Cable markers should be installed at an interval not exceeding 30 mtr. along the straight routes of cables at a distance of 0.5 mtr. away from centre of cable with the arrow marked on the cable markers plate indicating the location of cable. Cable markers should also be used to identify change in direction of cable route and for location of every joint in underground cable.
- RCC hump pipe for crossing road in cable laying shall be provided by employer. No deduction shall be made for cable laying in hump pipe for not providing bricks, sand and excavation. RCC hump pipe at the ends shall be sealed by bituminous compound after laying and testing of cables by electrical contractor without any extra charge.

LAYING OF CABLE IN MASONRY TRENCHES

- Masonry / concrete trenches for laying of cables shall be provided by employer. However, steel members such as M.S. angles / flats etc. shall be provided and grouted by electrical contractor to support the cables without any extra charge. Cables shall be clamped to these supports with minimum saddles / clamps. More than one tier of cables can be provided in the same trench if the no. of cables are more.
- Entry of cables in trenches shall be sealed with bituminous MASTIC compound to stop entry of water in trenches.

LAYING OF CABLES IN CABLE TRAYS

- Cable trays and steel members such as M.S. angle / channel / flats etc. shall be provided and fixed by the erector.
- Cable shall be fixed in cable trays in single tier formation and cables shall be clamped with aluminum flat clamps and galvanized bolts / nuts.
- Earthing flat / wire can also be laid in cable tray along with cables.
- After laying of cables, minimum 20% area shall be spare.

TERMINATION AND JOINTING OF CABLES

- a) For HT cables suitable size of Raychem termination kit shall be used.

TECHNICAL SPECIFICATION

b) Use of glands:

All PVC cables up to 1.1 KV grade, armoured or unarmoured shall be terminated at the

equipment / junction box / isolators / push buttons / control accessories, etc. by means of suitable size double compression type cable glands. Armour of cable shall be connected to earth point. The contractor shall drill holes for fixing glands wherever necessary. Wherever threaded cable gland is to be screwed into threaded opening of different size, suitable galvanized threaded reducing bushing shall be used of approved type.

In case of termination of cables at the bottom of the panel over a cable trench having no access from the bottom, close fit holes should be drilled in the bottom plate for all the cables in one line, and then bottom plate should be split in two parts along the centre line of holes. After installation of bottom plate and cables with glands, it shall be sealed with cold sealing compound.

USE OF LUGS / SOCKETS

All cable leads shall be terminated at the equipment terminals, by means of crimped type solderless connectors unless the terminals at the equipment ends are suitable for direct jointing without lugs / sockets.

The following is the recommended procedure for crimped joints and the same shall be followed:

- a) Strip off the insulation of the cable and with every precaution, not in severe or damage any strand. All insulation's to be removed from the stripped portion of the conductor and ends of the insulation should be clean and square.
- b) The cable should be kept clean as far as possible before assembling it with the terminal / socket. For preventing the ingress of moisture and possibility of re-oxidation after crimping of the aluminum conductors, the socket should be filled with corrosion inhibiting compound. This compound should also be applied over the stripped portion of the conductor and the palm surface of socket.
- c) Correct size and type of socket / ferrule / lug should be selected depending on size of conductor, and type of connection to be made.
- d) Make the crimped joint by suitable crimping tool.

TECHNICAL SPECIFICATION

- e) If after crimping the conductor in socket / lug, some portion of the conductor remains without insulation the same should be covered sufficiently with PVC tape.
- f) For HT cable up to 11 KV the manufacturer's recommendations should be followed.

DRESSING OF CABLE INSIDE THE EQUIPMENT

After fixing of cable glands, the individual cores of cable shall be dressed and taken along the cable ways (if provided) or shall be fixed to the panels with polyethylene straps. Cable shall be dressed in such a manner that small loop of each core is available inside the panel.

For motors of 20 HP and above, terminal box if found not suitable for proper dressing of aluminum cables, the erector shall modify the same without any additional cost.

Cables inside the equipment shall be measured and paid for.

IDENTIFICATION OF CABLES / WIRES / CORES

Power cables shall be identified with red, yellow and blue PVC tapes. For trip circuits identification, additional red ferrules shall be used only in the particular cores of control cable at the termination points in the switchgear / control panels and control switches.

In case of control cables all cores shall be identified at both ends by their wire numbers by mean of PVC ferrules or self-sticking cable markers, wire numbers shall be as per schematic / connection drawing. For power circuit also, wire numbers shall be provided if required as per the drawings of switchgear manufacturer / supplier.

TESTING OF CABLES

- Before energizing, the insulation resistance of every circuit shall be measured from phase to ground. This requires 3 measurements if one side is grounded and 6 measurements for 3 phase circuits.
- Where splices or terminations are required in circuits rated above 650 volts, measure insulation resistance of each length of cable before splicing and/or

TECHNICAL SPECIFICATION

terminating. Repeat measurements after splices and/or terminations are complete.

- DC high voltage test shall be made after installation on the following :

- a) All 1100 volts grade cables in which straight through joints have been made.
- b) All cables above 1100 V grade.

For record purpose test data shall include the measured values of leakage current vs time.

The DC high voltage test shall be performed as detailed below :

Cables shall be installed in final position with the entire straight through joints complete.

Terminations shall be kept unfinished so that motors, switchgear, transformer etc. are not subjected to test voltage.

The test voltage and duration shall be as per relevant codes and practices of Indian Standards Institution.

PROFORMA FOR TESTING CABLES

DATE OF TEST

- | | |
|-------------------------------------|----------|
| a) Drum No. from which cable taken. | |
| b) Cable from to | |
| c) Length of run of this cable | meter |
| d) Insulation resistance test | |
| i) between core-1 to earth | mega-ohm |
| ii) between core-2 to earth | mega-ohm |
| iii) between core-3 to earth | mega-ohm |
| iv) between core-1 to core-2 | mega-ohm |
| v) between core-2 to core-3 | mega-ohm |
| vi) between core-3 to core-1 | mega-ohm |
| vii) duration used: 1 KV | |

TECHNICAL SPECIFICATION

- | | Voltage | Duration |
|------------------------------|---------|----------|
| e) High voltage test | | |
| i) between core and earth. | | |
| ii) between individual cores | | |

[This Performa shall be jointly signed by the CLIENT / CONSULTANT and the contractor in duplicate].

1.35 Rigid PVC Pipes:

All non-metallic PVC conduits shall conform to IS: 9537 (Part - 3). The conduit shall be planned and of type as specified in IS: 9537 and shall be used with the corresponding accessories (Refer IS: 3419 specifications for fittings for rigid non-metallic conduits).

Installation of the system

A. Concealed Installation with Rigid PVC Conduit

- a. All the rigid PVC conduit used for concealed installation shall be as per IS ; 9537 and its accessories shall be as per IS: 3419 (Small Wire Ropes).
- b. Whenever necessary bends or diversion may be achieved by bending the conduits with the help of bending spring. No other method of bending is allowed.
- c. Conduit pipes shall be joined with the help of plain coupler fixed at the end with the help of vinyl solvent cement. No other method of joining is permissible.
- d. All other methods, no wires through conduit, bunching, etc. Shall be as specified in the concealed installation.
- e. Prior to fixing the conduits, the complete route shall be marked on site for the approval of consultant.

B. Concealed Wiring System with Rigid PVC Conduit

- a. The rigid PVC conduits shall be used for concealed wiring system. The conduits shall be concealed in the concrete slab, floor, walls, beams, columns etc.
- b. FIXING OF CONDUIT
 - i. Conduits embedded in concrete shall be installed in the framework before pouring concrete. The conduits shall be installed above the bottom reinforcing bars and shall provide positive wire fastening of the conduit to the reinforcing rods at an interval of not more than one meter, but on either side of couplers or bends or putlet/pull/junction boxes or similar fittings, proper hold fast shall be fixed at a distance of 30 cm from the center of such fittings. Conduits embedded in the wall shall be fixed inside the chase. The chase in the wall shall be neatly made and be fixed in the manner

TECHNICAL SPECIFICATION

desired. In the case of building under construction, chase shall be provided in the wall at the time of their construction and shall be filled up neatly with cement mortar 1:4 after erection of conduit and brought to the original finish of the wall. Cutting of horizontal chases in walls is prohibited. The conduits shall be fixed inside the chase by means of staples or by means of saddles not more than 60 cm apart.

- ii. Conduits shall be so arranged as to facilitate easy drawing of wires through them. Entire conduit layout shall be done in such a way as to avoid additional junction boxes other than light points. The wiring shall be done in a looping manner. All the looping shall be done in either switch boxes or outlet boxes. Looping in junction or pull boxes are strictly not allowed. Where conduits cross building expansion joints, adequate expansion fittings or other approved devices shall be used to take care of any relative movement.
- iii. All conduits shall be installed so as to avoid steam and hot water pipes.
- iv. Conduits shall be installed in such a way that the junction, derivation and pull boxes shall always be accessible for repairs and maintenance work. The location of junction/pull boxes shall be marked on the shop drawings and approved by the client.
- v. A separation of 200 mm shall be maintained between electrical conduits and hot water lines in the building.
- vi. No run of conduit shall exceed ten mtr. between adjacent draw in points nor shall it contain more than two right angle bends, or other derivation from the straight line
- vii. Caution shall be exercised in using the PVC conduits in location where ambient temperature is 50 degree cen. or above. Use of PVC conduits in places where ambient temperature is mote than 60 deg. cen. Is prohibited. The entire conduit system including boxes shall be thoroughly cleaned after completion of installations and before drawing of wires. Conduit system shall be erect and straight as far as possible. Traps where water may accumulate from condensation are to be avoided and if unavoidable, suitable provision for draining the water shall be made
- viii. All jointing method shall be subject to the approval of the client
- ix. Separate conduits shall be provided for the following system.
 - 15A power outlets.
 - 5A outlets and lighting system.
 - Low voltage system.
 - Telephone/intercom system.
 - C.C.T.V. system
 - Sound system
 - Computer data cabling system
 - Equipment wiring

C. Conduit Joint

TECHNICAL SPECIFICATION

- a. Conduits shall be joined by means of plain couplers vinyl and/or solvent cement. Where there are long runs of straight conduit, inspection type couplers shall be provided at intervals , as approved by the client
- b. The conduits shall be thoroughly cleaned before making the joints
- c. In case of plain coupler joints, proper jointing material like a vinyl solvent cement (gray in color) or any material as recommended by the manufacturer shall be used

D. BENDS IN CONDUIT

Wherever necessary, bends or diversions may be achieved by bending the conduits or by employing normal bends. No bends shall have radius less than 2.5 times outside dia. of the conduit

Heat may be used to soften the PVC conduit for bending, but while applying heat to conduit, the conduit shall be filled with sand to avoid any damage to the conduit

s

E. OUTLETS

All the outlets for fittings, switches etc. shall be boxes of substantial construction. In order to minimize condensation or sweating inside the conduits, all outlets of conduit system shall be properly drained and ventilated, but in such a manner as to prevent the entry of insects, etc.

Fixing between conduit and boxes, outlet boxes, switch boxes and the like must be provided with entry spouts and smooth PVC bushes.

Joints between conduit and any type of boxes shall be affected by means of conduit couplers in to each of which shall be coupled smooth PVC bush from inside the box. In any case all the joints shall be fully water tight.

F. BUNCHING OF CABLES

Cables of AC supply of different phase shall be bunched in separate conduits

The number of insulated wires/ cables that may be drawn into the conduits shall be as per the following table. In this table, the space factor does not exceed 40%. However, in any case conduits having lesser than 19 mm dia. shall not be used.

MAXIMUM PERMISSIBLE NUMBER OF 650 VOLT GRADE SINGLE CORE CABLES THAT MAY BE DRAWN IN TO RIGID PVC CONDUITS.

CABLE SIZE IN (MM SQ.)	SIZE OF CONDUITS (MM)			
	MAXIMUM NO. OF CABLES			
	25	32	38/40	51/50

TECHNICAL SPECIFICATION

1.5	8	15	---	---
2.5	6	10	---	---
4.0	4	8	12	---

Seal and Signature of the Bidder

Addl. City Engineer

TECHNICAL SPECIFICATION

1.0 LIST OF APPROVED MAKES FOR FIRE PROTECTION WORKS

SR. NO.	DESCRIPTION	APPROVED MAKE / APPROVED VENDOR
01	Fire Extinguishers	Kanex / Minimex / Safex / New Age
02	Auto Glow Signages	Autoflow / Glowlite / Prolite / Autoglo
03	Pipe	Tata / Jindal / Surya / Alp
04	Pipe Fittings	Jainsons / Unik / Vr / Sant
05	Coating & Wrapping	lwl / Rustek / Neotape / Pypecoat
06	Painting	Asian / Nerolac / Berger
07	RCC Pipes	Indian Hume Pipe / Pranali / Alcock
08	Pressure Switches	Switzer / Indfoss / Danfoss
09	Pressure Gauge	H. Guru / Fiebig / Hd Fire / A.N. Instruments
10	Fire Hydrants Valve	Newage / Sukan / Winco / Shah Bhogilal/ Sant / Swati
11	Rrl Hose	Newage / Shah Bhogilal / Crc/ / Sant / Swati
12	Fire Hose/ Coupling Branch Pipe/ Nozzles	Newage / Sukan / Shah Bhogilal / Crc / Sant / Swati
13	Fire Brigade Inlet	Newage / Sukan / Shah Bhogilal / Crc / Sant / Swati
14	Fire Hose Reel	Newage / Shah Bhogilal / Sri / Crc/ Sant / Swati
15	Fire Hose Cabinet	Newage / Shah Bhogilal
16	Pumps	Grundfos / Kirloskar / Ksb
17	Motor	Kec / Siemens / Cgl / Abb
18	Diesel Engine	Koel / Greaves / Groundfos / Mather Platt / Kirloskar
19	Battery	Exides / Amco / Amaron
20	Battery Charger	Servlink / Hbl / Chhabi
21	Sprinklers	H.D / Tyco / Viking / Fm Approved
22	Flow Switches	Danfoss / Forbes / Marshall / Switzer / System Sensor / Potter / Honeywell
23	Ss Corrugated Flexible Pipes Braided Type	H.D. Fire / Tyco / Viking / New Age / Rapidrop / Victaulic / Fm Approved
24	Adjustable Rosset Plate	H.D. Fire / Tyco / Viking
25	Engineered Support System	Mupro / Easy Flex / Griple / Fischer
26	Non-Return Valve	Sant/Zoloto/Leader/Honeywell / Advance
27	Cast Iron Grating	Kapilansh / Neco

TECHNICAL SPECIFICATION

SR. NO.	DESCRIPTION	APPROVED MAKE / APPROVED VENDOR
28	Pump On Off Switch	Jain Instruments / N.K.Techno Fab / Rss
29	Electric Meters	Schneider / Nippen / L & T / Socomec / Secure / Elmeasure / Ducati / Siemens / Abb
30	Starter / Switches / Mcb / Mccbs / Etc.	Siemens / L&T / Schneider
31	Switchgear / Sfus	L & T / Siemens / Schnieder
32	Frls Cables	Finolex / Polycab / Havells
33	Frls Wires	Finolex / Polycab / Havells
34	Butterfly Valve	Audco / L&T / Advance / Sant
35	Sluice Valve	Audco / L&T / Advance / Sant
36	Ball Valve	Audco / L&T / Advance / Sant
37	Strainer	Audco / Intervolve / Sant
38	Pressure Reducing Valve	Honeywell / Bermad
39	Relays	L&T / Siemens / C&S
40	Pump Panel	Cpri Approved
41	Air Release Valve	Sant / Zoloto / Shah Bhogilal/
42	Welding Electrodes	Advani / Maruti / Esab
43	Clamps / Fasteners	Hilti / Fischer / Mupro
44	Test Drain Assembly With Sight Glass	Tyco / Viking / Grinnel
45	Primer	Asian Paints / Berger / Nerolac
46	Ss Expansion Bellow	Flexatherm
47	Alarm Control Valve/ Installation Control Valve	Tyco/ Hd/ Newage (Mumbai)/ Newage (Surendranagar)/ Viking/ Globe
48	Air Vessel	Nema/ Zenith/ As Per Cpwd Specifications Tested Up To 25kg/ Sqmtr
49	Anti-Vibrating Mounting Pads/ Expansion Joints	Dulop/ Resistoflex/ Easy Flex/ Flexionics/ Vimpa

Seal and Signature of the Bidder

Addl. City Engineer